



BOURNS® TCS™ TRANSIENT CURRENT SUPPRESSOR WHITE PAPER

A New Circuit Protection Device for VDSL Applications



Bourns® TCS™ Devices



TVS Diodes

INTRODUCTION

Since the first electronic equipment was designed, engineers have had to deal with protecting their equipment against electrical surges, primarily Electrostatic Discharge (ESD) and lightning.

Equipment interfaces can be exposed to a wide range of discharge events up to and including surges caused by lightning. Even with ESD-immune optical fibers transmitting data long distances, connection from the optical-electrical interface equipment to offices and residential buildings is still primarily through external conventional electrical cabling, exposing this equipment to high energy electrical surges.

Modern electronics, in the quest for ever higher speed and lower cost, use ever denser IC technologies whose sensitivity to surges creates an increasingly difficult challenge for designers of electronic equipment. As technology advances, conventional circuit protection solutions have become less effective in protecting sensitive electronics from surges. Furthermore, these conventional solutions struggle to meet the signal integrity requirements for very high-speed transmissions.

This white paper examines how the new Bourns® Transient Current Suppressor (TCS™) protection device can meet the surge protection and transmission performance challenges of modern communication systems.

A New Circuit Protection Device for VDSL Applications

LIMITATIONS OF THE TRANSIENT VOLTAGE SUPPRESSOR

Basic Operation of a Voltage Limiting Device

Electronic protection devices have been developed to absorb ESD energy at the interface, and one of the most commonly used devices is a Transient Voltage Suppressor (TVS) diode. The basic operation of a TVS diode is very simple (see figure 1). Ideally, it has an electrical characteristic as shown in figure 2, whereby the device appears as high impedance to the interface in the normal range of the signal working voltage that passes over the line. Only when the surge at the interface exceeds a preset limit does the TVS diode become conductive, abruptly limiting the voltage from rising above this level.



Bourns® TCS™ Devices



TVS Diodes

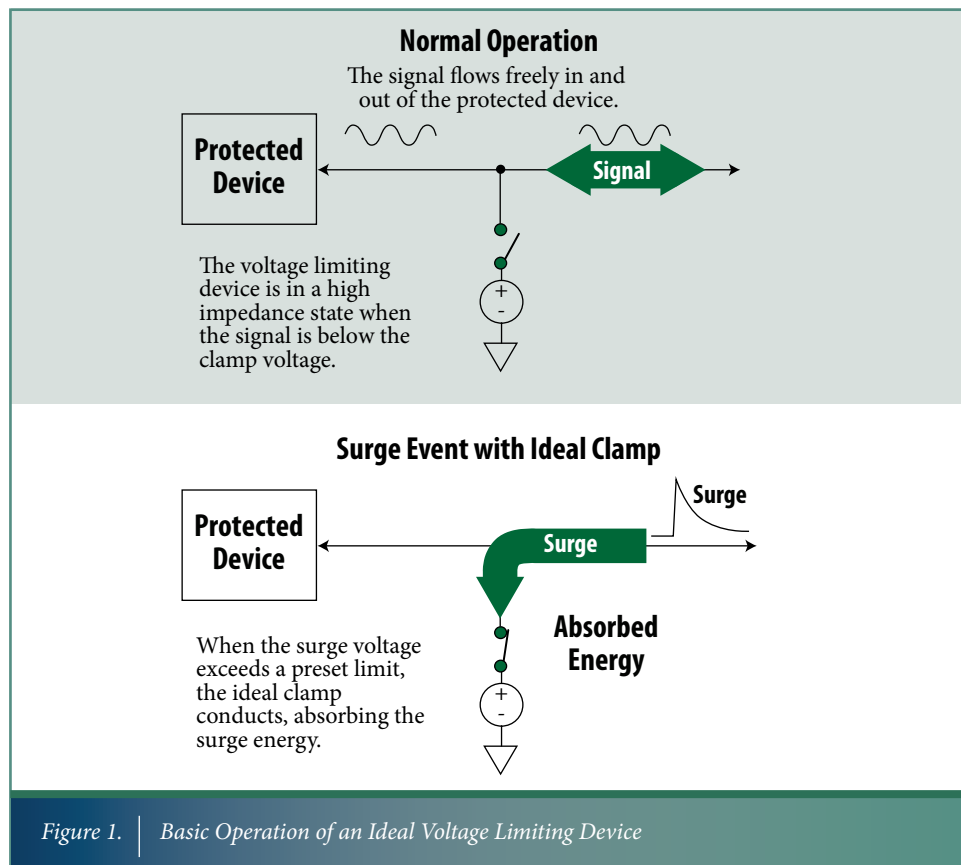

The ideal TVS diode thus has a “brick wall” clamping characteristic which causes no interference to the normal signal, yet prevents the voltage at the interface from ever going beyond a level that may be dangerous to the equipment.

A New Circuit Protection Device for VDSL Applications

LIMITATIONS OF THE TRANSIENT VOLTAGE SUPPRESSOR (*Continued*)



Bourns® TCS™ Devices



TVS Diodes

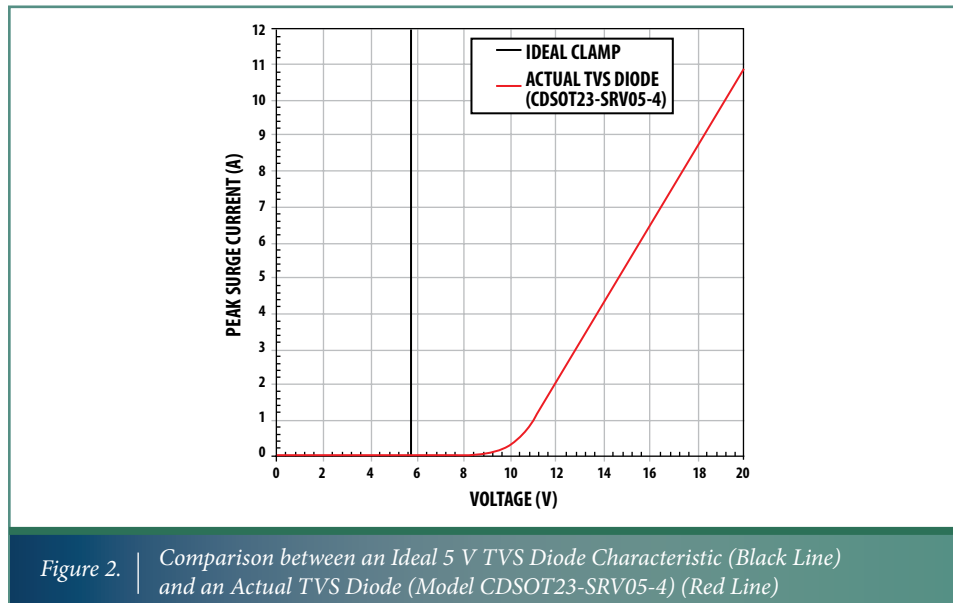

Figure 2. Comparison between an Ideal 5 V TVS Diode Characteristic (Black Line) and an Actual TVS Diode (Model CDSOT23-SRV05-4) (Red Line)

In practice, a TVS diode appears high resistance until the breakdown voltage of the junction is reached. Beyond that point, the diode junction supports current flow in the form of avalanche, Zener or punch-through breakdown, depending upon the construction of the device.

As the current level increases further, a distinct gradient is seen, caused by the significant internal resistance of the TVS diode. As ESD devices may have to withstand tens or even hundreds of amps for short durations, the actual peak voltage that may be seen across the device, and therefore, across the line will be significantly higher than the onset of breakdown. The internal resistance is a function of the junction area, and achieving acceptably low clamping voltage at high levels of current may require very large junctions, which greatly impacts cost and package size.

It becomes apparent that simply connecting a TVS diode between an interface and ground is ineffective in protecting the device driving that interface. The device will see the peak voltage developed across the TVS diode, and as seen in figure 2, that voltage may reach 20 V during a discharge of 11 A, which is far beyond the capability of many low voltage technologies. Instead of effectively shielding the interface device from the surge, the TVS diode simply diverts a portion of the energy away, still leaving the device exposed to high voltages and currents. This remaining energy seen by the protected device is often termed “let-through energy”.

BOURNS® TCS™ TRANSIENT CURRENT SUPPRESSOR WHITE PAPER

A New Circuit Protection Device for VDSL Applications

LIMITATIONS OF THE TRANSIENT VOLTAGE SUPPRESSOR *(Continued)*



Bourns® TCS™ Devices



TVS Diodes

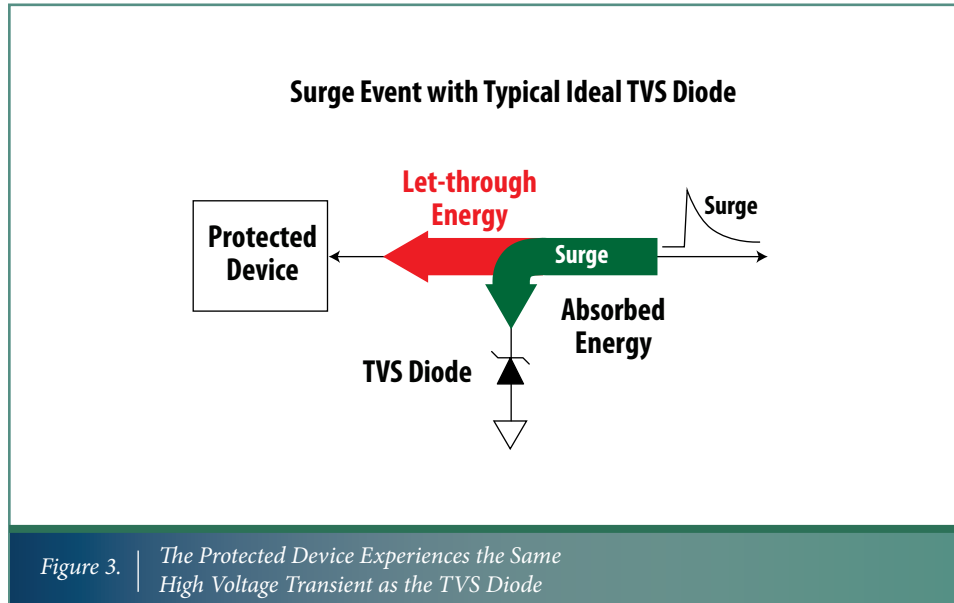

The potentially high level of let-through energy under surge conditions can be a major problem when using conventional TVS diodes for the protection of sensitive electronics in harsh environments.

A New Circuit Protection Device for VDSL Applications

IMPACT OF TVS CAPACITANCE ON SIGNAL INTEGRITY

As data rates and transmission distances increase, a further consideration is the high frequency characteristics of the surge protection device during normal line use. High capacitance can cause unacceptable high frequency attenuation in the circuit, significantly limiting the capacity to drive high data rates.

Junction capacitance is non-linear, and the dynamic capacitance variation with signal voltage can result in unacceptable harmonic distortion of the waveform, causing spurious noise harmonics which can drastically impact the achievable data rates over long distances in multi-tone systems such as VDSL.

Capacitance is another critical parameter that is proportional to the junction area; the larger the TVS diode, the higher the capacitance becomes.

PROTECTION VS. PERFORMANCE VS. COST

The lower voltage TVS diodes have become increasingly difficult and expensive to produce as interface driver device voltage systems such as Gigabit Ethernet have decreased, firstly from 5 V to 3.3 V, and then to 2.5 V and most likely in the future, even lower. For these lower voltage devices, more complex TVS diode designs must be used, as conventional diode junctions present increasingly high resistance and high leakage at low voltages.

These TVS diodes have a structure resembling an open base transistor, which gives rise to a low voltage “punch-through” characteristic, rather than an avalanche or Zener breakdown to control the clamp characteristics. This type of TVS diode often exhibits a degree of “fold-back”, whereby the clamping voltage drops as the clamp current initially begins to increase. A fold-back characteristic significantly helps to reduce the increase in clamping voltage at higher currents, but adds very significantly to the device complexity and cost compared to a simple P-N junction diode.



Bourns® TCS™ Devices



TVS Diodes

BOURNS® TCS™ TRANSIENT CURRENT SUPPRESSOR WHITE PAPER

A New Circuit Protection Device for VDSL Applications

BOURNS® TCS™ TRANSIENT CURRENT SUPPRESSOR: A NEW APPROACH

The problems inherent in achieving ideal TVS characteristics, in combination with the growth in high-speed, low voltage applications that must withstand severe levels of lightning surge and ESD, invite an alternative approach. The basic limitations of the TVS diode stem from it being a single-stage protection device. Even the best voltage limiting device does not prevent current flow into the protected device, which can reach destructive levels.

The Transient Current Suppressor (TCS™) device is a new approach that significantly improves the level of protection when used in a two-stage configuration together with a voltage limiting device, in series with the protected signal line. The actual characteristics of the TCS™ device are shown in detail in figure 4.



Bourns® TCS™ Devices



TVS Diodes

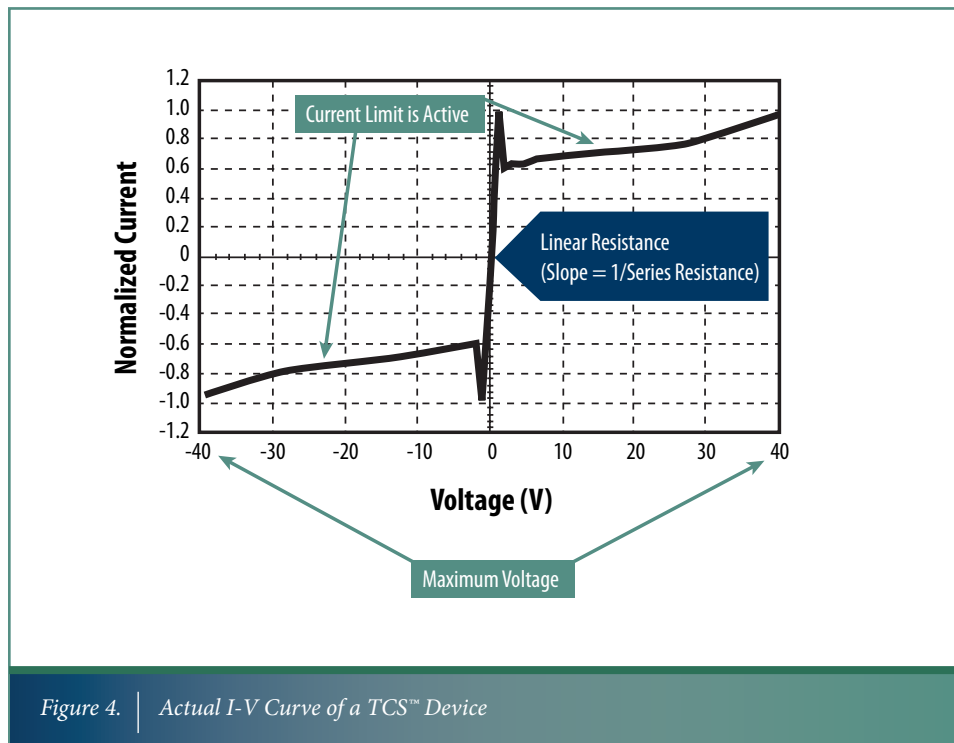

In normal operation, when currents are low, the TCS™ device behaves as a low value resistor. When the current is driven above a certain limit, the TCS™ device transitions very rapidly into a current limiting state.

BOURNS® TCS™ TRANSIENT CURRENT SUPPRESSOR WHITE PAPER

A New Circuit Protection Device for VDSL Applications

BOURNS® TCS™ TRANSIENT CURRENT SUPPRESSOR: A NEW APPROACH (Continued)

The TCS™ device configuration and circuit symbol are shown in figure 5.

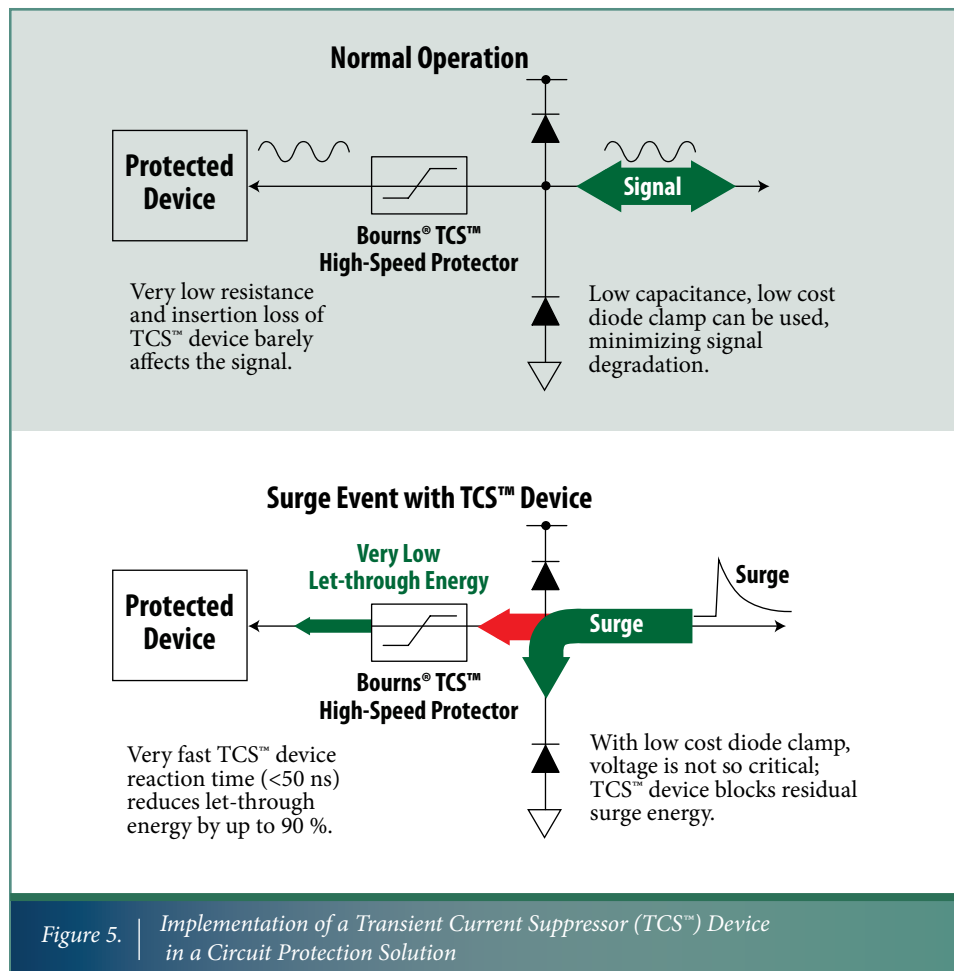

The TCS™ device drastically reduces stress by adding a current limiting stage in series with the protected device to complement the characteristics of the voltage limiting device. When a surge occurs, the voltage at the interface increases, causing current to flow through the TCS™ device. As the current limit is reached, the TCS™ device very rapidly prevents a further increase in current within its rated limits by allowing the voltage across itself to increase, effectively presenting a very high resistance. As the current is limited to a constant level, the voltage at the protected device no longer rises and stays within a safe level. On the other side of the TCS™ device, the voltage continues to rise until the activation voltage of the voltage clamping device is reached.

BOURNS® TCS™ TRANSIENT CURRENT SUPPRESSOR WHITE PAPER

A New Circuit Protection Device for VDSL Applications

BOURNS® TCS™ TRANSIENT CURRENT SUPPRESSOR: A NEW APPROACH (Continued)



Bourns® TCS™ Devices



TVS Diodes

When used in conjunction with a TCS™ device, the first stage clamp voltage level no longer needs to be critically chosen to match the protected device and its clamping characteristic may be much softer (resistive) than a single stage TVS diode would need to be. The voltage across the clamp voltage device can continue to rise, with the maximum limitation now being that the differential voltage developed across the TCS™ device must stay within the breakdown 40 V voltage limit of the TCS™ device, a condition that is much easier to achieve, using most forms of voltage clamp.

As its name implies, the Transient Current Suppressor (TCS™) device is directly analogous to the TVS diode; whereas the TVS diode limits transient voltages, the TCS™ device limits transient currents. The simplified current and voltage characteristic diagrams in figure 6 show this comparison.

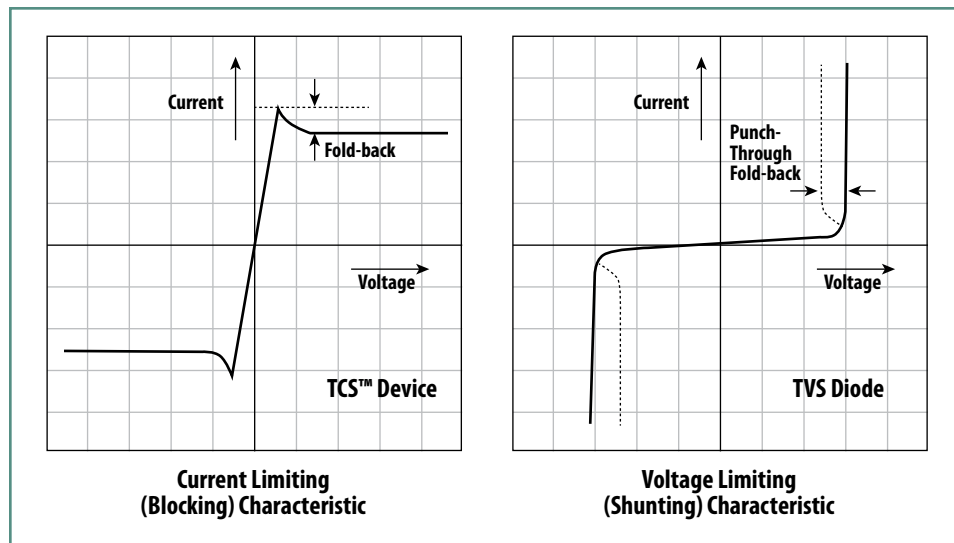

Figure 6. | Complementary Characteristics of the TCS™ Device and TVS Diode

As can be seen from the characteristics, the TCS™ device, like the punch-through TVS diode, also exhibits a degree of fold-back, whereby the current drops approximately 30 % from its maximum value as the voltage increases further. This fold-back helps to minimize stress in the protected device and also improves transient power handling in the TCS™ device.

BOURNS® TCS™ TRANSIENT CURRENT SUPPRESSOR WHITE PAPER

A New Circuit Protection Device for VDSL Applications

BOURNS® TCS™ TRANSIENT CURRENT SUPPRESSOR: A NEW APPROACH (Continued)

Several device options of resistance and current limit are available, and can be chosen for optimal cost and performance in the application:



Bourns® TCS™ Devices



TVS Diodes

Table 1. TCS™ Device Options

| Device | Typical Resistance (Ω) | Typical Current Limit (mA) |
|--------------------------|---------------------------------|----------------------------|
| Dual Channel 40 V 250 mA | 2.3 | 375 |
| Dual Channel 40 V 500 mA | 1.4 | 750 |
| Dual Channel 40 V 750 mA | 1 | 1125 |

The TCS™ device acts like a conventional linear low value resistor in series with the line, so there is no physical connection to ground for internal parasitic capacitance to occur. As with a resistor, the only significant capacitance is due to the capacitance between the body of the TCS™ device and its surroundings. Therefore, for minimum capacitance, care should be taken during layout so that no electrical traces or planes are run under the packaged device. In particular, ground and voltage planes should have windows cut out directly beneath the device pads. When designed in this way, the capacitive loading effects of the TCS™ device are negligible, even well up into the GHz region, making the TCS™ device ideal for enhancing the protection of very high-speed data buses.

The speed of the current limiting operation of the TCS™ device is ideal for protecting against standard lightning surge test waveforms (1.2/50 μ s, 10/1000 μ s, etc.). The typical response time to achieve limiting operation is less than 50 ns. A very fast rising transition from zero current at rates greater than 5 kV/ μ s may cause the current to momentarily overshoot the nominal current limit by a small amount for a very short interval, but the amount of additional let-through energy during this interval is negligible and has no impact on the high level of protection afforded by the TCS™ device.

Dual channel TCS™ devices contain two well-matched series resistances in one package. For example, the TCS™ Dual Channel 40 V 750 mA device with a nominal resistance of 1 Ω is matched to just within 20 m Ω . Like resistors, TCS™ devices can be connected in parallel to give an even lower resistance. The individual transient current suppressors in a dual TCS™ device can be paralleled to act as a single device with half the resistance and twice the current limit. If two matching parallel connected TCS™ devices are required, two dual devices can be used, with one transient current suppressor from each package connected in parallel to one transient current suppressor from the other package to retain good matching.

BOURNS® TCS™ TRANSIENT CURRENT SUPPRESSOR WHITE PAPER

A New Circuit Protection Device for VDSL Applications

BOURNS® TCS™ TRANSIENT CURRENT SUPPRESSOR: A NEW APPROACH (Continued)

When used with even a basic voltage clamping device such as simple relatively high resistance signal diode clamps as in figure 5, the composite behavior of the TCS™ device in conjunction with a voltage clamping device closely corresponds to that of the ideal “brick wall” clamping device, as shown in figure 7.



Bourns® TCS™ Devices



TVS Diodes

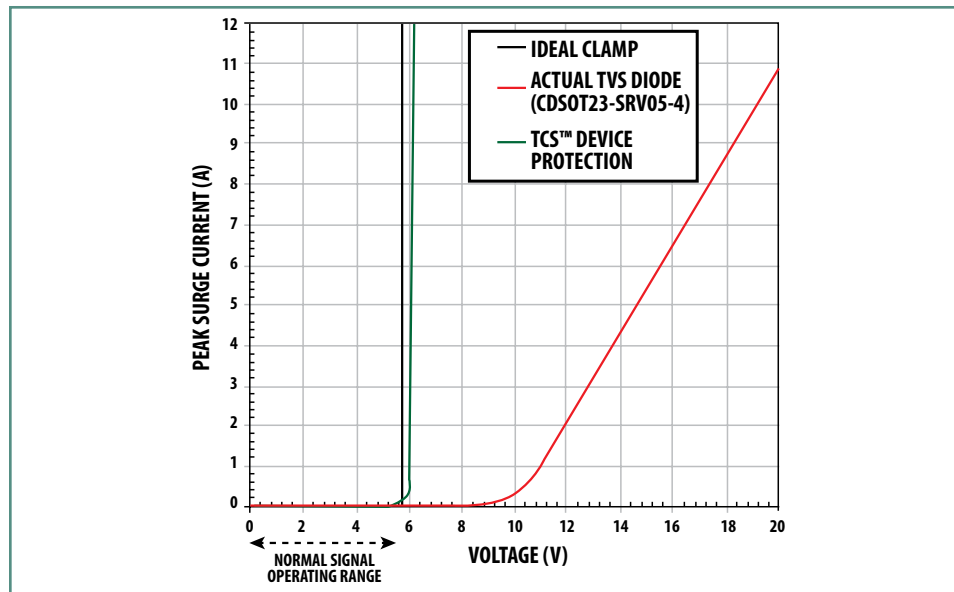

Figure 7. | The TCS™ Device Model TCS-DL004-250-WH Behaves Like an Ideal Clamp Compared Against TVS Diode Model CDSOT23-SRV05-4

The table below shows how the TVS diode and TCS™ device have complementary characteristics:

Table 2. | TVS Diode and TCS™ Device Complementary Characteristics

| TVS Diode | TCS™ Device |
|--|--|
| Limits voltage | Limits current |
| Parallel connection | Series connection |
| Shunting (shorting) protective action | Blocking (limiting) protective action |
| Very high resistance below maximum voltage | Very low resistance below maximum current |
| Very low resistance above maximum voltage | Very high resistance above maximum current |
| Adds parallel capacitance | Negligible parallel capacitance |
| Junction (bipolar) construction | Field-effect (MOS) construction |

BOURNS® TCS™ TRANSIENT CURRENT SUPPRESSOR WHITE PAPER

A New Circuit Protection Device for VDSL Applications

EVALUATION OF VDSL APPLICATION

To demonstrate the effectiveness of the TCS™ device, we can compare its performance to a single-stage TVS diode. Figure 8 shows a basic test circuit that is representative of a VDSL design, using a single conventional TVS diode, Bourns® Model CDSOD323-T12C. In most designs, a single TVS diode is insufficient to protect the driver and additional clamping devices, such as TVS diodes or Metal Oxide Varistors (MOVs), are used across the transformer on the line side, or across the driver output. These have very significant impacts on VDSL performance. MOVs, for example, typically have capacitance close to 100 pF. However, for direct comparison purposes, this simplified test circuit will demonstrate the effectiveness of the TCS™ device protection system.



Bourns® TCS™ Devices



TVS Diodes

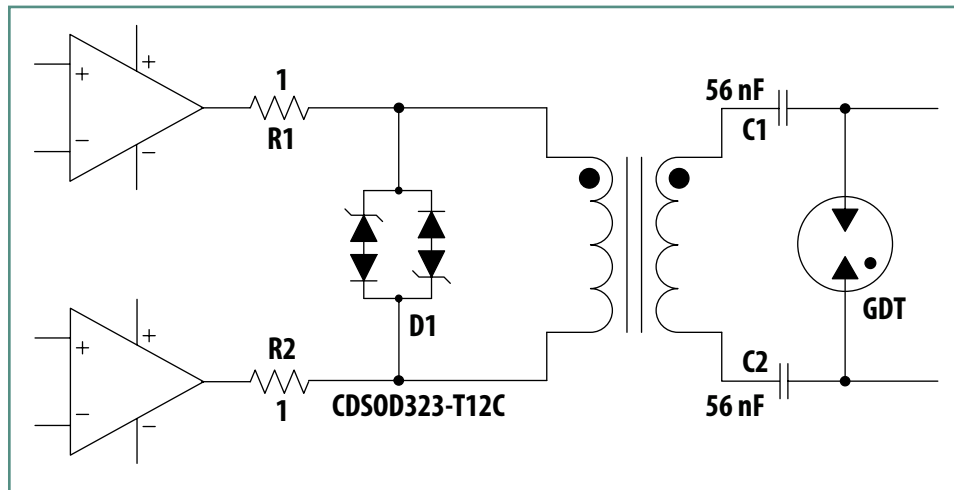

Figure 8. | Basic VDSL Test Circuit Using a Single TVS Diode

BOURNS® TCS™ TRANSIENT CURRENT SUPPRESSOR WHITE PAPER

A New Circuit Protection Device for VDSL Applications

EVALUATION OF VDSL APPLICATION (Continued)

DSL circuits in general are often exposed to high levels of stress when lightning surge transient voltages occur on the line. C1 and C2 are used to block DC bias voltages that may be present on POTS (Plain Old Telephone System) lines¹. The surge causes the line side capacitors to charge, following the surge voltage as it rises to the point that the Gas Discharge Tube (GDT) fires. When this occurs, the GDT appears as a switch that has been suddenly closed and the charged capacitors are thus instantly switched directly across the line side winding of the transformer. The capacitor voltage, which is charged by the surge up to 500-1000 V, is then coupled across to the driver side winding. Very high discharge currents flow through the line side winding as the capacitors rapidly discharge through the GDT, which in turn induces current flow in the driver side, equal to that in the line side multiplied by the turns ratio of the transformer, as shown in figure 9.



Bourns® TCS™ Devices



TVS Diodes

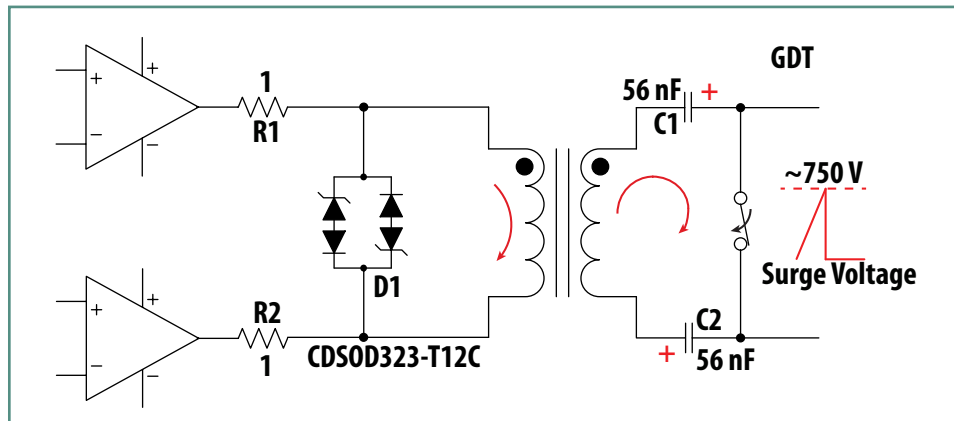

Figure 9. | Equivalent Effect of GDT Firing, Causing Line Capacitor Discharge

VDSL transformers commonly have a turns ratio ranging from 1:1 up to 1:4.5, depending upon the driver type. A typical value for VDSL circuits is 1:1.4, and this was used in the test circuit. In the VDSL circuit, the driver is typically configured for active termination such that its output acts as virtual line termination. A combination of current and voltage feedback is used so that the driver output impedance matches a significant portion of the reflected line impedance, as transformed through the driver transformer.²With a ratio of 1:1.1, the 100 Ω line impedance transforms to the driver side by $1/n$ where n is the turns ratio. In this case, the total equivalent resistance in the driver circuit including the R1 and R2 must equal $100/1.21 = 82.6 \Omega$. As a side note, it can be seen that at 2.3 Ω , the nominal resistance of even the higher resistance TCS™ device is very small in comparison to the driver side impedance, and has a negligible effect on the VDSL signal.

¹ Two capacitors were used in this test circuit in order to withstand the maximum voltage seen during surge. Often a single higher voltage capacitor is used in the center tap instead; this does not affect the protection performance of the circuit.

² Bias resistors of 10 k Ω between the Zener and the supply rails can be used to minimize diode capacitance effects (not shown).

BOURNS® TCS™ TRANSIENT CURRENT SUPPRESSOR WHITE PAPER

A New Circuit Protection Device for VDSL Applications

EVALUATION OF VDSL APPLICATION *(Continued)*

R1 and R2 contribute to the protection, in that they provide some current limiting between the voltage developed across the TVS diode and the output of the driver. However, their values must be kept relatively low compared to the line termination resistance, in order to limit the amount of signal voltage dropped across them during normal operation. Values can typically range between 1 to 5 Ω ; the lower value being used in this test.

To demonstrate the TCS™ device effectiveness, the 1 Ω resistors were replaced by a dual TCS™ device with a nominal resistance of 1 Ω and a nominal current limit of 1.125 A, as shown in figure 10. To provide the necessary first stage of voltage clamping, the TVS diode was replaced by a simple diode clamp using generic signal diodes, type CDSOT23-S2004, clamping to a generic 12 V Zener (e.g. BZT52C12). This configuration forms an extremely low cost and very low capacitance clamp, with the clamping diodes specified as typically 3 pF, the same as the Bourns® Model CDSOD323-T12C.



Bourns® TCS™ Devices



TVS Diodes

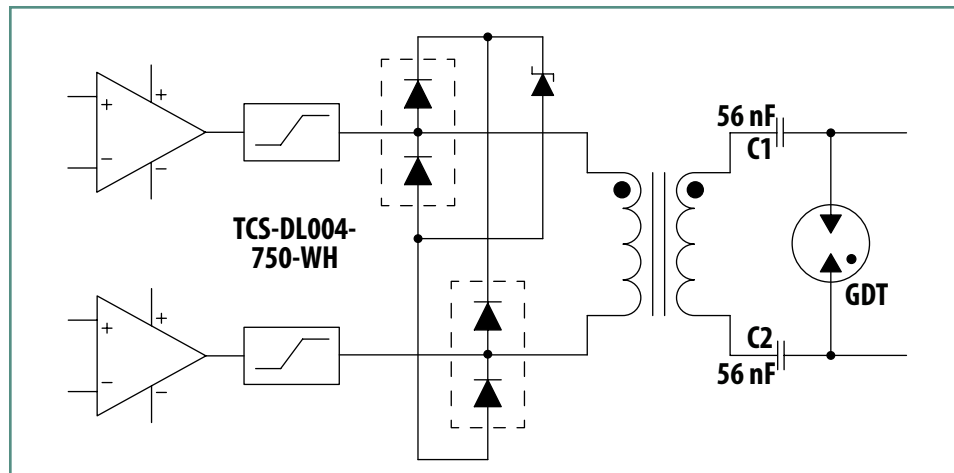

Figure 10. | TCS™ Device Protection Using Low Cost Generic Diode Clamp



BOURNS® TCS™ TRANSIENT CURRENT SUPPRESSOR WHITE PAPER

A New Circuit Protection Device for VDSL Applications

EVALUATION OF VDSL APPLICATION *(Continued)*

A 10/1000 μ s surge was applied to the line in both cases: the waveform is seen in figure 11, showing the voltage across the GDT at the point at which it fires, at around 750 V. Also, the current flowing in the driver side winding is shown, reaching a maximum of almost 60 A.



Bourns® TCS™ Devices



TVS Diodes

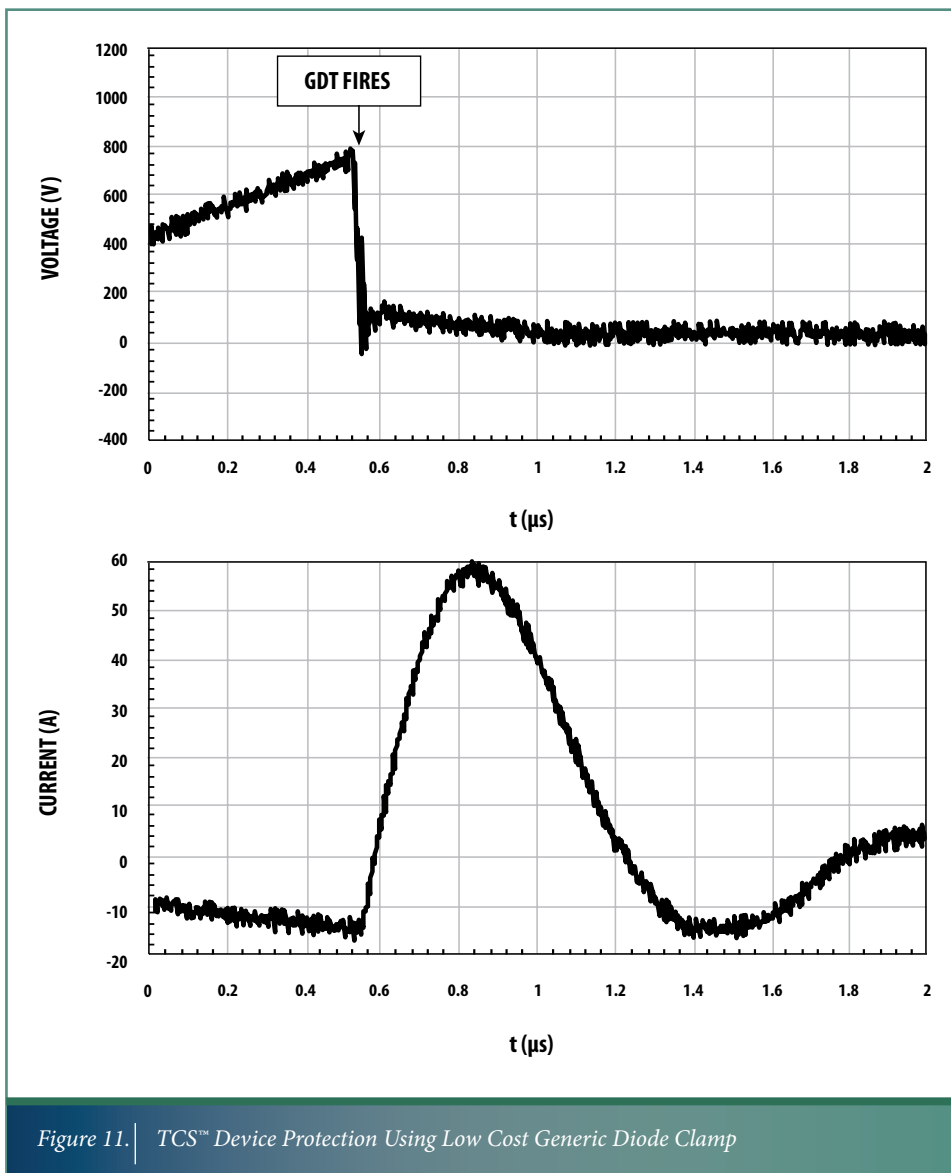

Figure 11. | TCS™ Device Protection Using Low Cost Generic Diode Clamp

BOURNS® TCS™ TRANSIENT CURRENT SUPPRESSOR WHITE PAPER

A New Circuit Protection Device for VDSL Applications

EVALUATION OF VDSL APPLICATION *(Continued)*

The resulting waveforms of the voltages and currents in the circuit can now be compared. In figure 12, the voltage at the top of the transformer winding is shown, indicating the effectiveness of the clamping device. The Bourns® Model CDSOD323-T12C TVS clamping circuit is shown in the top figure, and the TCS™ device circuit using low cost diodes is shown in the lower figure. It can be seen that the TVS clamp has lower clamping resistance, and clamps the voltage to 30 V, rather than 46 V in the case of the TCS™ device clamp.



Bourns® TCS™ Devices



TVS Diodes

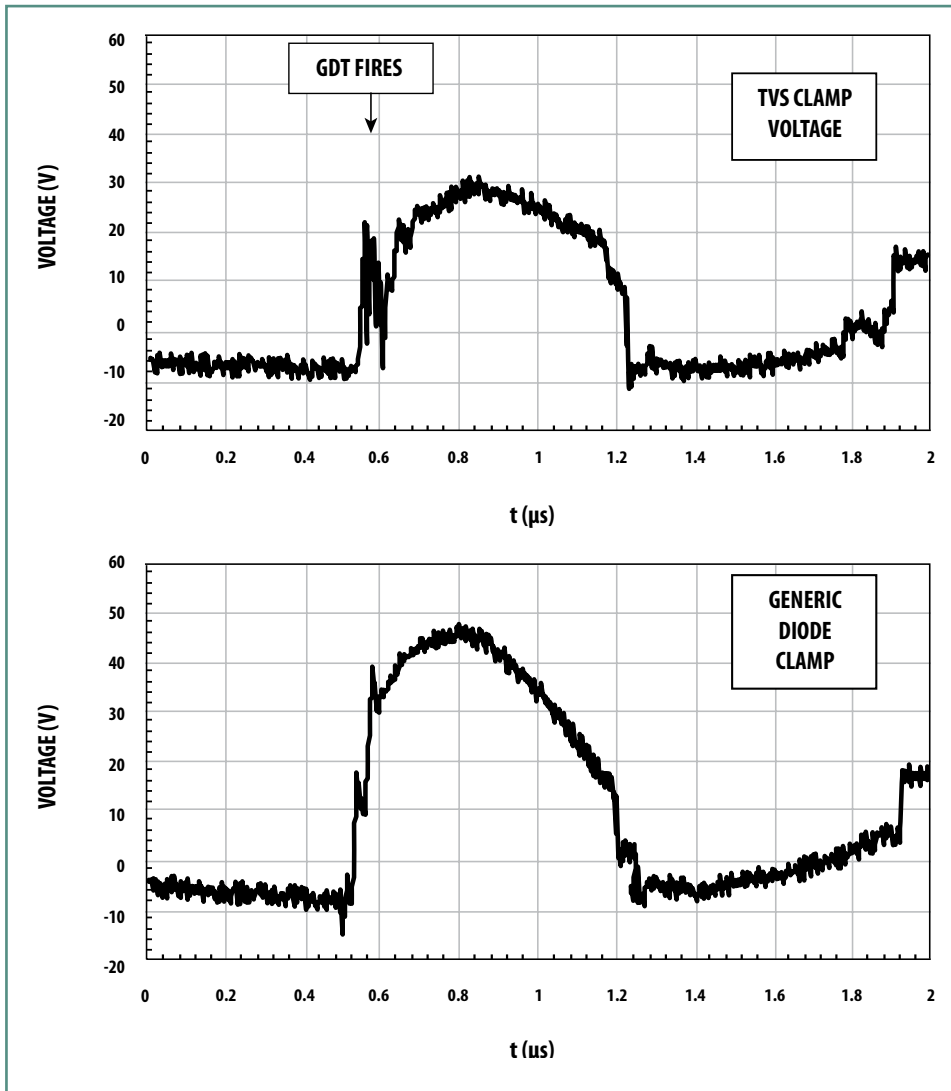

Figure 12. Comparison between TVS Clamp Voltage (Top) and Generic Diode Clamp Used with TCS™ Device (Bottom)

A New Circuit Protection Device for VDSL Applications

EVALUATION OF VDSL APPLICATION *(Continued)*

As mentioned previously, while this demonstrates the effectiveness of the TVS diode relative to higher resistance, low cost devices, the peak voltage using a single TVS diode is much greater than many VDSL drivers can withstand. This can be readily appreciated when the current into the driver is measured, as seen in figure 13. The top graph shows the current into the driver, using only the TVS diode. Even though the TVS diode voltage clamping is much better than low cost diode clamping, the peak current is almost 11 A, which is generally sufficient to damage many drivers through Electrical Overstress (EOS).

However, in the case of the TCS™ device circuit, the current into the driver is almost an order of magnitude lower. The current can be seen to rise rapidly, reach a maximum of around 1.8 A, then quickly fold back to a lower level of 1 A for the duration of the voltage surge. Even though the peak voltage across the simple diode clamp is 46 V, the voltage at the output of the driver never exceeds 13 V (1 V above the supply rail).

The amount of energy dissipated in the driver during the surge is much lower using the TCS™ device than when using a single TVS diode. Even when the TVS circuit is further improved by the addition of extra protection across the line side of the transformer, the surge energy experienced by the driver is still more than an order of magnitude higher than when using the TCS™ device circuit.

The advantages of this two stage protection now become evident:

- far higher levels of surge can be withstood than when using conventional single stage protection, allowing lower cost, less robust interface devices to be used
- low voltage interface devices (such as 3.3 V drivers) no longer require a high cost, low voltage TVS type diode - a much lower cost generic higher voltage clamping device can be used
- the need for a very low slope resistance TVS diode to approximate a “brick wall” vertical performance is eliminated
- the clamping device can be considerably smaller, adding much less capacitance to the line because the voltage clamping requirements are greatly relaxed
- very low cost clamping methods can be used, such as simple generic signal diode clamps to decoupled supply rails or to a generic Zener diode
- a very well-controlled and greatly reduced level of stress is achieved at the protected device under surge test conditions, eliminating uncertainty in production due to variations in robustness of the protected device, or through variation between suppliers



Bourns® TCS™ Devices



TVS Diodes



BOURNS® TCS™ TRANSIENT CURRENT SUPPRESSOR WHITE PAPER

A New Circuit Protection Device for VDSL Applications

EVALUATION OF VDSL APPLICATION (Continued)



Bourns® TCS™ Devices



TVS Diodes

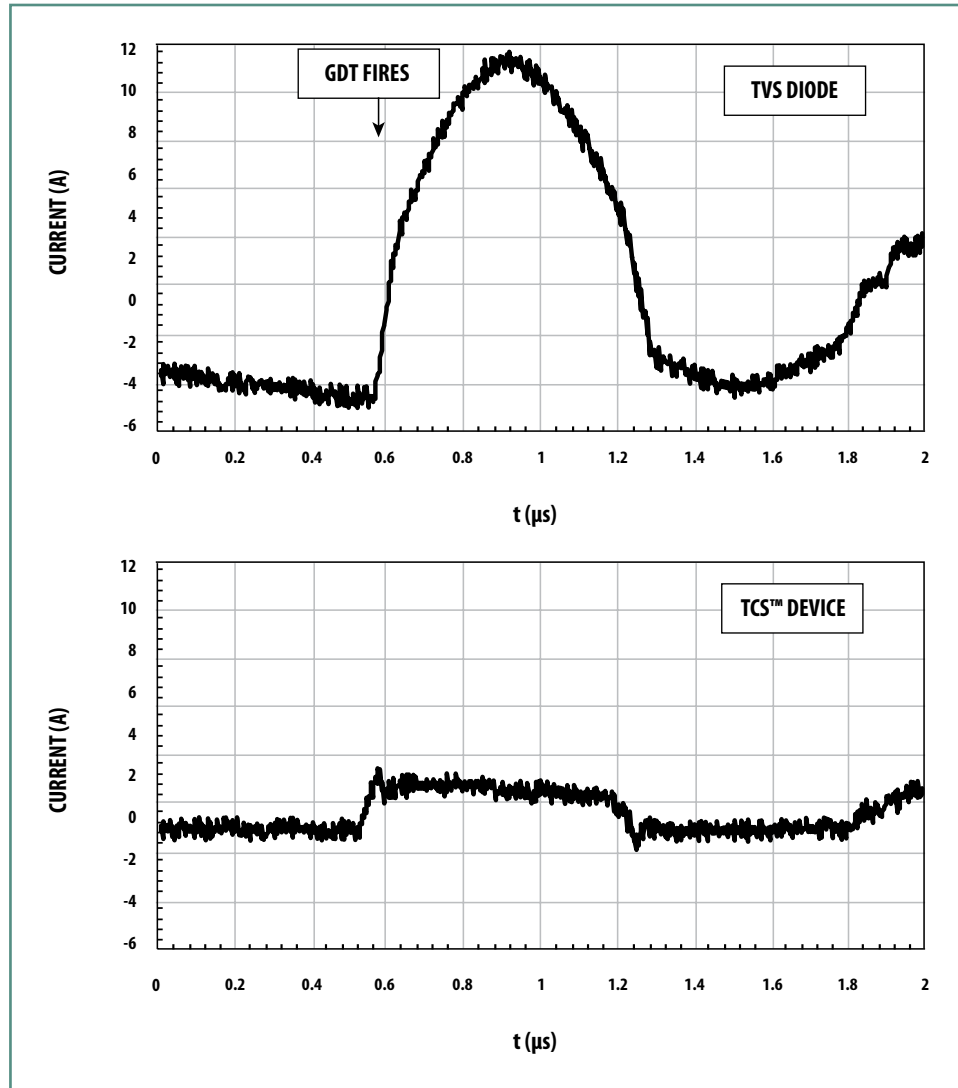

Figure 13. Driver Current with TVS Diode (Top) and TCS™ Device (Bottom)



BOURNS® TCS™ TRANSIENT CURRENT SUPPRESSOR WHITE PAPER

A New Circuit Protection Device for VDSL Applications

SUMMARY

In summary, the Bourns® TCS™ device is a welcome addition to the world of circuit protection, providing superior protection and excellent transmission performance to high-speed communication systems like Gigabit Ethernet and xDSL. Unlike conventional TVS diode protection, the improvement in robustness is not at the expense of adding capacitive devices that rob bandwidth and reduce data rate performance. Designers can very simply achieve cost-effective protection that is far superior to even multiple stage TVS diode circuits, while not compromising transmission performance.



Bourns® TCS™ Devices



TVS Diodes

REFERENCES

Additional information about Bourns® products can be found online at:

www.bourns.com

COPYRIGHT© 2012 • BOURNS, INC. • 9/12 • e/TCS1213

TCS is a trademark of Bourns, Inc.

Bourns is a registered trademark of Bourns, Inc. in the U.S. and other countries.

BOURNS®

9/12 • e/TCS1213

Americas: Tel +1-951 781-5500
Fax +1-951 781-5700

EMEA: Tel +41-(0)41 768 55 55
Fax +41-(0)41 768 55 10

Asia-Pacific: Tel +886-2 256 241 17
Fax +886-2 256 241 16