

Understanding IGBT Data Sheet Parameters

WHITE PAPER

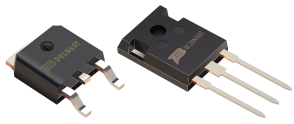

Bourns® BID Series IGBTs

INTRODUCTION

Technology continues to advance such that higher voltage and current applications demand ever-increasing power efficiencies. The solution designers have used historically to maximize efficiency are metal-oxide-semiconductor field-effect transistors (MOSFETs). Since application requirements have progressed, MOSFETs cannot always optimize efficiency at the operating voltages currently specified. To achieve lower switching losses with these next-generation applications, alternative technologies exist that have the features required to achieve design goals.

One solution is the [insulated-gate bipolar transistor \(IGBT\)](#), which is a combination of a power MOSFET control gate with a power NPN bipolar junction transistor. High power IGBTs have gained popularity as switching components in medium-to-high power converter designs such as in motor control, power conversion, energy storage and industrial applications.

This white paper provides general information about IGBT power semiconductors and, in particular, provides explanations about component parameters and graphs in Bourns' IGBT data sheets available at www.bourns.com. Information about power MOSFET and bipolar transistors is also included for comparison purposes to aid in understanding the parameters and characteristics presented in an IGBT data sheet.

It is important to note that the data sheet values for switching characteristics refer to specific test setups and will be different for each individual application circuit. Most of the graphs shown in this white paper are taken from the data sheet for the Bourns® Model BIDW50N65T IGBT. The data sheet is available at www.bourns.com, along with the whole family of IGBT data sheets. Also note that the diagrams of semiconductor layers and doping concentrations are not to scale. Most of the data sheet parameters are specified at a case temperature, T_c , of 25 °C, though some are specified at elevated temperatures of 100 °, 125 °, or 150 °C. Thus, it is important to observe the temperature at which the parameters are specified.

Understanding IGBT Data Sheet Parameters White Paper



[Bourns® BID Series IGBTs](#)

INSIDE THE PAIR

What is it that makes the combination of a MOSFET and a bipolar junction transistor (BJT) such an advantageous solution? One aspect is that the IGBT's MOS gate incorporates the technology of the historically-favored solution, namely the MOSFET. Paired with a BJT's increased current capability and reduced saturation voltage, these characteristics are leveraged by the IGBT. Plus, an IGBT behaves much like a MOSFET, so it does not require a drastic departure from previous understanding. Advancements in technology have made the IGBT an optimal solution for high current and high temperature applications due to the stability offered by its combined technologies.

Not all IGBTs are the same, however, and a review of some basic architecture is helpful to understanding the technology. Two foundational styles of IGBTs are punch-through (PT) and non-punch-through (NPT). NPT is symmetric, which means the forward and reverse breakdown voltages are the same. It consists of four layers: injection, drift, body, and source. Whether it is in forward bias or reverse bias, the blocking capability is determined by the negatively doped drift region.

The PT style is asymmetric, so the forward breakdown voltage is greater than the reverse breakdown voltage. Additionally, its structure is more complicated than the NPT due to the addition of a buffer layer as the fifth layer: injection, buffer, drift, body, and source. In forward bias its blocking capability is determined by the negatively doped source region, whereas in reverse bias that same blocking capability is determined by the positively doped source region.

[The IGBTs](#) in the Bourns portfolio are all trench-gate field stop technology, so the next distinction between IGBT styles is planar gate versus trench gate. Planar is much like the word implies, layering plane upon plane to form the layers of the device. This generally means wide layers and a wide gate that is exposed to three substrates in a plane across the top of the device. In contrast, the trench gate's exposure is rotated 90 degrees to penetrate down from the gate contact into the three substrates. The trench structure provides enhanced performance by reducing conduction and switching loss. A drastic reduction in the thickness of the die, which now is a mere 20 % of the equivalent planar structure die thickness, provides a significantly lower temperature resistance. Like MOSFETs, IGBT performance is affected by temperature, so this can prove an important point.

Given a field-stop structure with trench gate in Bourns' IGBT families, the next consideration is the presence or absence of a field stop. Incorporating a field stop results in reduced switching losses and a lower-saturation voltage drop. By implanting a field stop and back emitter, the dynamic behavior of the IGBT is more easily controlled. The combined field-stop structure with trench gate, a field stop and back emitter results in greater robustness overall, which is why Bourns has adopted this IGBT construction style.

Understanding IGBT Data Sheet Parameters White Paper



Bourns® BID Series IGBTs

IGBT GENERAL OVERVIEW

While IGBTs may offer substantial benefits compared to traditional MOSFETs, the parameters and behaviors of IGBT technology must be understood before specifying this device in a particular application. Many important parameters of the IGBT contribute to the success of a highly efficient, robust application design. To avoid severe IGBT degradation or even destruction, careful attention must be given to the device's maximum operating temperature, voltage and current ratings, and gate drive conditions. These features are the main factors affecting longevity of an IGBT in each particular application.

Efficiency is determined by the switching, or dynamic, conditions that are observed in the overall design including transformer performance, inductor parameters and gate drive details. Much of the performance of an individual IGBT in a specific application is determined by the mounting, printed wiring board, and surrounding component parameters, such as for inductors and transformers. To optimize a design, those components and the specific gate drive waveforms for the gates must be taken into consideration in the analysis.

A few basic steps characterize IGBT switching. A positive voltage is applied from the gate to the emitter terminals and causes the collector-to-emitter path to conduct current with a low $V_{ce(sat)}$. This allows the current in the external circuit to flow and perform the designed function. Removing the gate voltage stops the current flow. With detailed care, the power loss at the on and off switching times is minimized.

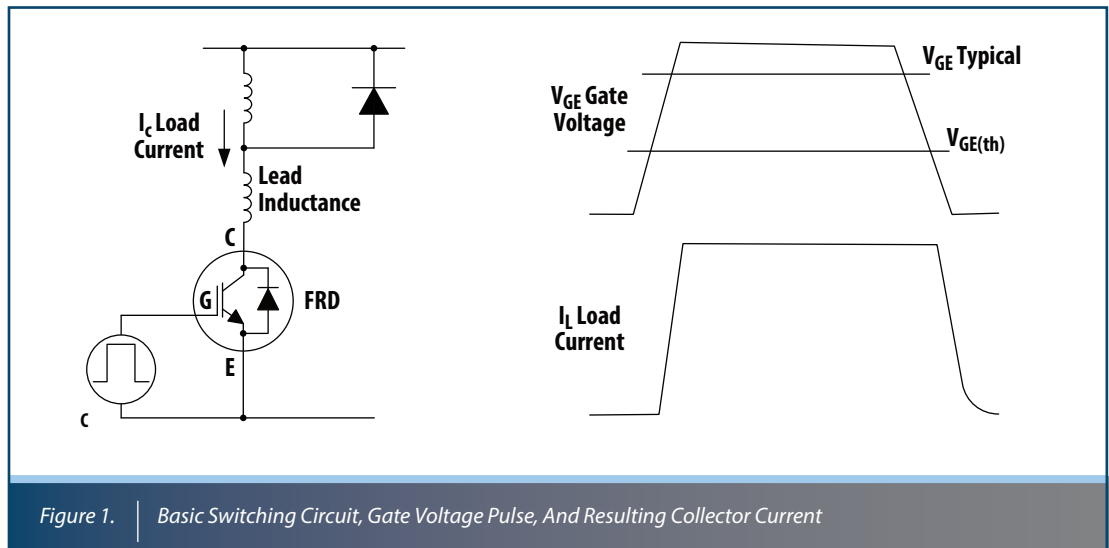

IGBTs combine the control gate input of a MOSFET and the collector-emitter structure of a power NPN bipolar junction transistor (BJT). This combination provides lower switching losses for high voltage and high current applications, at operating voltages where MOSFETs cannot optimize efficiency. The basic switching function is shown in Figure 1. When the gate to emitter voltage rises above the threshold, the collector current flows. When it drops below the threshold, current flow stops. The emitter is the common point, or ground, in the operation and testing of the IGBT unless specified otherwise.

Understanding IGBT Data Sheet Parameters White Paper



Bourns® BID Series IGBTs

MAXIMUM ELECTRICAL RATINGS

It is not the intent of this section to imply that the IGBT can be used with several or all of the parameters at their maximum limits. Quite to the contrary, if any of the electrical ratings are exceeded, degradation or damage to the IGBT can be expected. Examining the maximum limits in the data sheet gives designers insight into the IGBT's operation in actual operating conditions, which should be verified by the designers. As with any switch, each type of IGBT has a specific maximum voltage denoted by V_{CES} so that it can switch without damage or degradation. This is the maximum voltage level, whether during switching or steady state, that can appear across the collector to emitter connections. The voltage between gate and emitter is specified by V_{GE} and is the maximum drive voltage that can be applied to the gate.

The maximum current that the IGBT can switch is specified by I_C , whether operating in steady state (continuously), or during a pulse, when the maximum pulsed current is denoted by I_{CP} . The highest forward current for the free-wheeling Fast Recovery Epitaxial Diode (FRD) is specified by I_f , or continuous forward current. This current will flow when the voltage on the collector is negative relative to the emitter. The highest reverse voltage on the FRD is the same as the maximum voltage the IGBT can switch without damage, V_{CES} . The short-circuit withstand time is the time that the IGBT is expected to conduct the maximum current available with the collector shorted to the supply and emitter grounded (V_{CE}) using the stated drive voltage (V_{GE}).

The time that the IGBT will conduct the maximum current is an indication of the capability of the IGBT package to move heat out of the junction quickly in the active semiconductor die. The maximum storage temperature, T_{STG} , is the permissible environmental temperature while the IGBT is not conducting current and in the absence of bias voltage. The maximum operating junction temperature, T_j , is the limit of the silicon junction temperature within the semiconductor die while operating in all circuit and fault conditions. Allowing the instantaneous junction temperature to exceed the maximum operating junction temperature, for example, during the short circuit withstand test, almost certainly would result in damage to the semiconductor die. The total power dissipation of the IGBT while maintaining the case temperature at 25 °C is denoted as P_{total} .

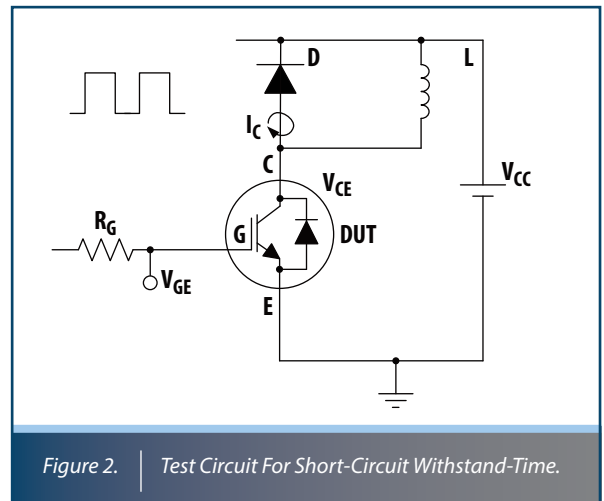

Figure 2. | Test Circuit For Short-Circuit Withstand-Time.

Understanding IGBT Data Sheet Parameters White Paper



[Bourns® BID Series IGBTs](#)

STATIC ELECTRICAL CHARACTERISTICS

The characteristics of the IGBT are distinct for static and dynamic electrical conditions. Static conditions will be explored first. The collector-emitter breakdown voltage specified by BV_{ceS} is the lowest voltage on the collector that causes the specified collector current. This is tested with the gate shorted to the emitter ($V_{ge} = 0$). Closely related to this is the collector current, denoted as I_{ceS} , also known as collector leakage current. This is the maximum current that will flow from collector to emitter at the specified voltage with the gate shorted to the emitter.

Another leakage current in the IGBT is the gate to emitter leakage current, denoted as I_{geS} . This indicates the maximum allowed current that flows from the gate to emitter at the specified voltage with the collector shorted to the emitter.

The gate drive threshold voltage, specified by $V_{ge(th)}$, is the gate voltage that starts current flowing from collector to emitter at the specified current. It is measured with the gate shorted to the collector. Recall that the emitter is the common point, or ground, in these measurements. The gate threshold voltage varies over a wide range due to die process variations and junction temperature.

When the IGBT is in the 'ON' condition with the specified gate voltage and collector current, the $V_{ce(sat)}$ parameter gives the voltage from collector to emitter. In an ideal switch, this would be zero.

Often in power conversion and current switching applications, the inductive load produces a negative voltage at the collector when the switch changes to the 'OFF' condition. At that time, the FRD will conduct a forward current in the free-wheeling operation of these applications. The voltage across the diode while conducting current in the forward bias condition is specified by V_f .

Understanding IGBT Data Sheet Parameters White Paper



Bourns® BID Series IGBTs

DYNAMIC ELECTRICAL CHARACTERISTICS

Moving on to the dynamic electrical characteristics introduces interactions specified by equations. The capacitances shown in Figure 3 are equivalent circuit capacitances between the internal regions of the semiconductor die and are measured at the conditions shown on the data sheet. These are used in the analysis of the application circuit switching performance.

$$C_{ies} = C_{ge} + C_{gc} \text{ with collector shorted to emitter}$$

$$C_{oes} = C_{ce} + C_{gc} \text{ with gate shorted to emitter}$$

$$C_{res} = C_{gc}$$

C_{gc} is very important because it provides a feedback loop between the output and the input of the circuit. Also called the Miller capacitance, it causes the total dynamic input capacitance to become greater than the sum of the static capacitances.

From a circuit design point of view, the charges are the more useful parameters rather than the capacitances. The capacitors internal to the IGBT must be charged and discharged to accomplish switching and must be charged or discharged to achieve the fully 'ON' or fully 'OFF' condition, respectively. The current and time required to accomplish this are related by the amount of charge required to change the voltage on them by:

$$\text{Total gate charge } Q_g \text{ (charge)} = I_g \text{ (gate current) multiplied by } t \text{ (time)}$$

Since the current is rarely constant, a more precise equation is given by:

$$Q_g = \int_0^t I_g dt$$

Regardless of the method of calculation, the total gate charge Q_g is the amount of charge required to bring the gate voltage from zero (0) to the voltage required to enable current flow at the specified voltage and current operating conditions.

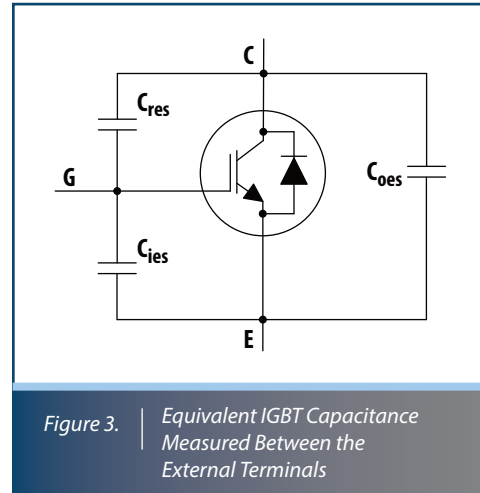

Understanding IGBT Data Sheet Parameters White Paper



Bourns® BID Series IGBTs

DYNAMIC ELECTRICAL CHARACTERISTICS (Continued)

The gate charge has two components. The process of enabling circuit current flow begins at time t_0 , as shown in Figure 4. The charge Q_{ge} is the charge that must be applied to the gate to allow the specified collector current at time t_2 . This voltage is above the gate threshold voltage $V_{g(th)}$, which the gate reaches at time t_1 . The charge Q_{gc} is the charge applied to the gate to achieve the lowest V_{ce} at time t_3 . More charge can be applied to the gate between times t_3 and t_4 to make sure the IGBT stays in the 'ON' state. This additional charge must be removed along with Q_{ge} and Q_{gc} to switch the IGBT back to the 'OFF' state.

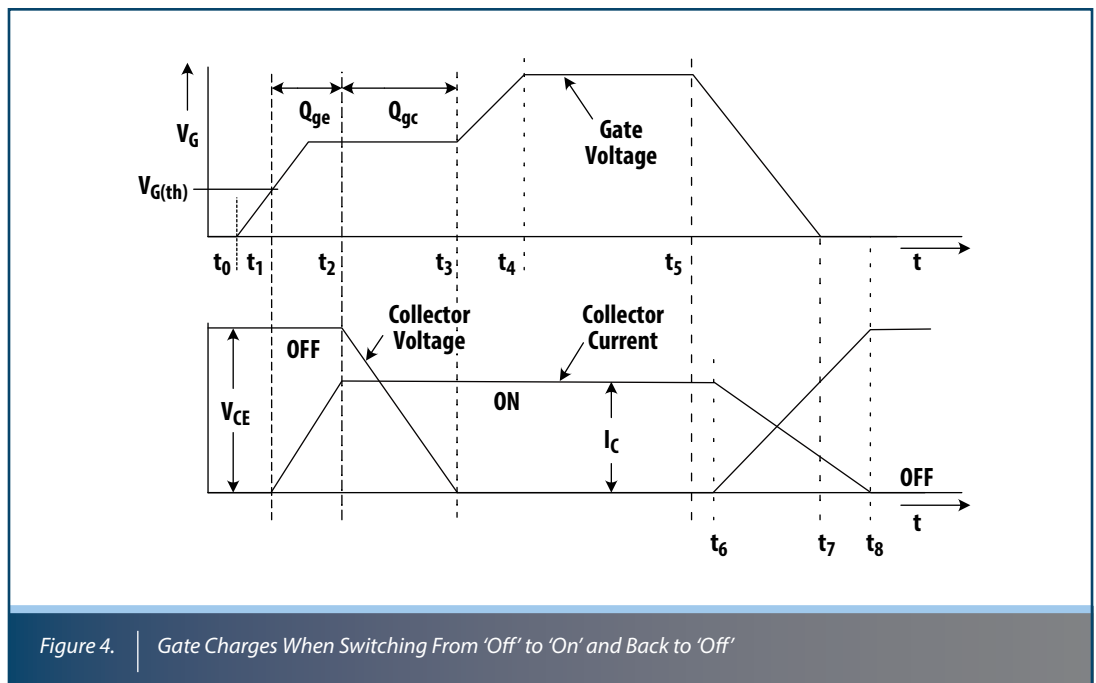

Figure 4. | Gate Charges When Switching From 'Off' to 'On' and Back to 'Off'

Understanding IGBT Data Sheet Parameters White Paper



Bourns® BID Series IGBTs

IGBT SWITCHING CHARACTERISTICS WITH INDUCTIVE LOAD

The behavior of the [IGBT](#) during switching is detailed in Figure 4. The time for the collector current to reach 10 % of the final value after the application of voltage to the gate is the turn-‘ON’ delay time $t_{d(on)}$, shown as the interval t_0 to t_1 . The collector current rise time from 10 % to 90 % of the specified current is specified by t_r in the interval t_1 to t_2 . The time needed for the current to decrease by 10 % after the reduction of gate voltage is the turn-‘OFF’ delay specified by $t_{d(off)}$, and is shown as the interval t_5 to t_6 . The collector current fall time, denoted as t_f , is in the interval t_6 to t_8 which is the time needed for the collector current to change from 90 % to 10 % of the ON current.

Power consumption during the switching times is the major part of efficiency loss. During ‘ON’ and ‘OFF’ times, either the voltage or current is nearly zero, so their power consumption is very low. During the switching times, t_1 to t_3 and t_6 to t_8 , the power dissipated is the product of collector current and voltage from collector to emitter. Because the voltage and current are much higher than zero at these times, significant power is dissipated. Integrating the instantaneous power over time at each switching transition gives the energy dissipated at each transition. E_{on} is the energy during the turn-‘ON’ switching time and E_{off} is the energy during the turn-‘OFF’ switching time. When added together, the total switching energy is E_{ts} .

It is helpful to visualize this in Figure 5, where the shaded areas are the energy and the envelopes around them are the power. Another contribution to device power loss is the conduction loss when the IGBT is ‘ON’ and conducting current. The power during this time is the collector current multiplied by the voltage from the collector to the emitter.

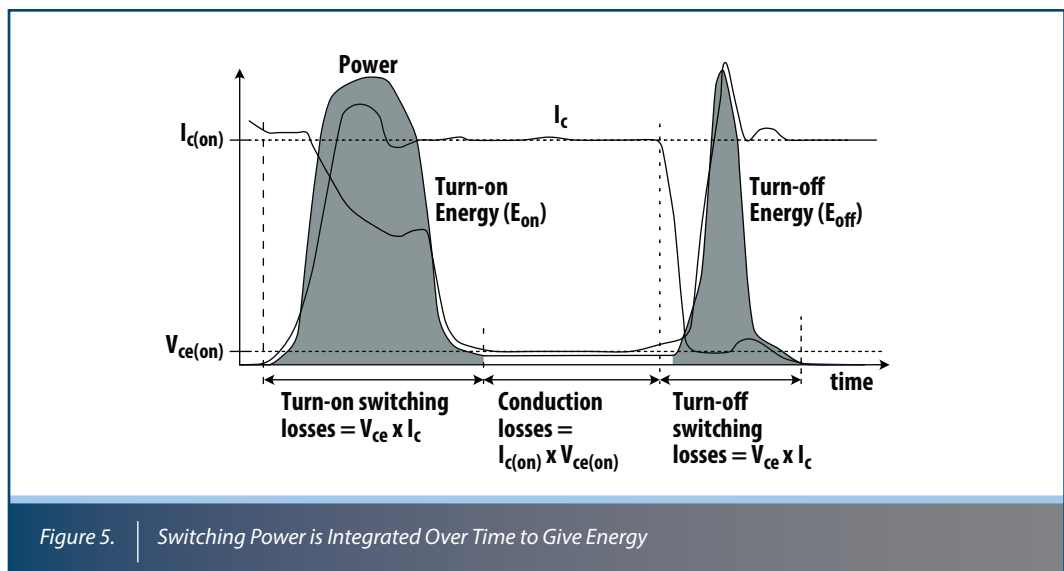

Understanding IGBT Data Sheet Parameters White Paper



[Bourns® BID Series IGBTs](#)

DIODE SWITCHING CHARACTERISTICS

Critical to the switching characteristics is the behavior of the diode. In addition to the forward conduction characteristics, the FRD has reverse recovery parameters. The reverse recovery time, specified by t_{rr} , is the same as any other diode. As shown in Figure 6, this is the time required for the diode to reverse polarity and stop conducting current. The reverse recovery charge is the amount of current over time that must come out of the diode before reverse current stops. In practical terms, the current integrated over the reverse recovery time is the reverse recovery charge Q_{rr} .

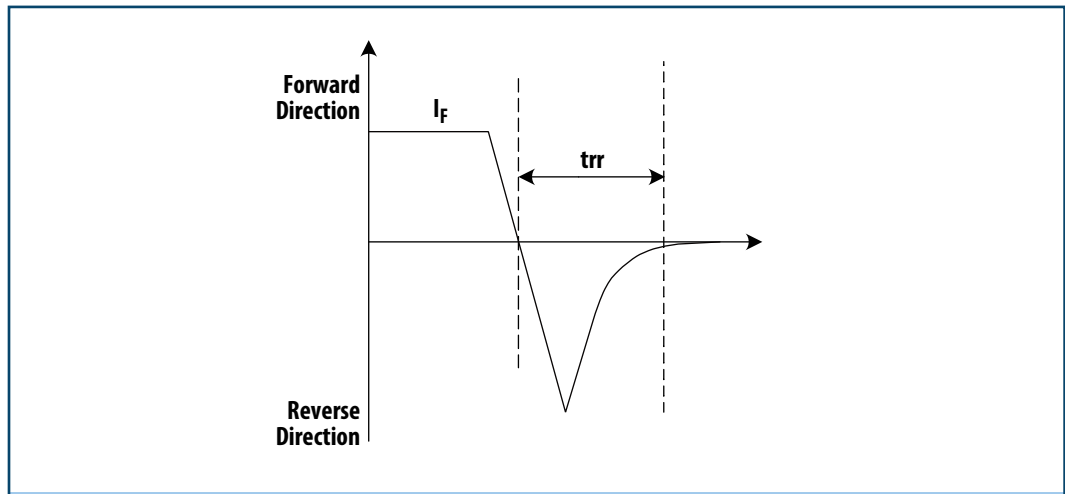

Figure 6. | FRD Diode Changing to Reverse Polarity and Stopping Current Flow, Shows Reverse Recovery Time T_{rr}

Understanding IGBT Data Sheet Parameters White Paper



Bourns® BID Series IGBTs

THERMAL RESISTANCE

Temperature and power dissipation are closely related. The thermal resistance expresses the difficulty of moving the heat generated in the semiconductor junction to the mounting surface of the IGBT package (the case), as captured in the photograph in Figure 7. Bourns® IGBTs are provided in thermally-efficient packages including TO-247 and TO-252.

The thermal resistance for the IGBT die is $R_{th(j-c)}_{IGBT}$ and for the FRD is $R_{th(j-c)}_{Diode}$. Because of power dissipation, these parameters are used in the calculation of the junction temperatures. The thermal resistance from the case to the heat sink is dependent on the mounting method and usually is included in the thermal resistance of the heat sink $R_{th(sink-ambient)}$. Most of the time the thermal resistance of the interface between the IGBT case and the heat sink $R_{th(case-sink)}$ is negligible compared to the other thermal resistances.

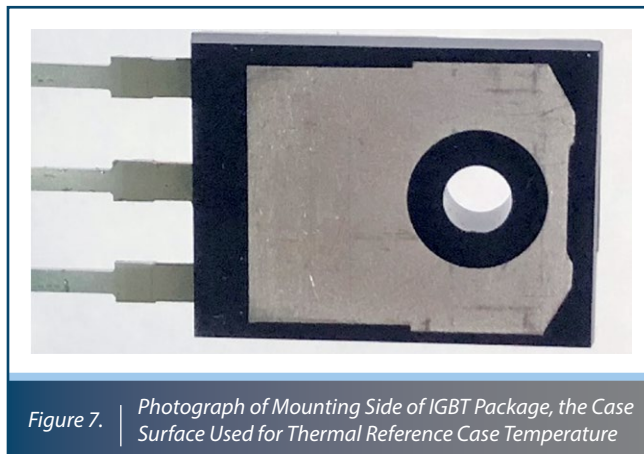

Figure 7. | Photograph of Mounting Side of IGBT Package, the Case Surface Used for Thermal Reference Case Temperature

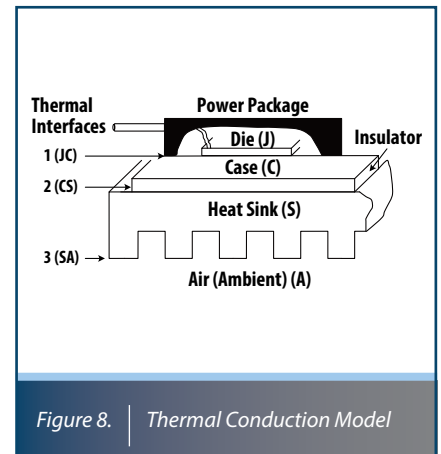

Figure 8. | Thermal Conduction Model

The package in Figure 7 contains two separate dice, the IGBT and the FRD. The temperature of the heat sink, $T_{(heat_sink)}$, is measured first due to the total power dissipated. Then the temperature of each junction is calculated. The thermal model is shown in Figure 8. The junction temperature of each junction is determined by the result of three calculations:

$$T_{(heat_sink)} = (Power_IGBT + Power_FRD) \times R_{th(sink-ambient)}$$

$$T_{(IGBT_junction)} = T_{(heat_sink)} + Power_IGBT \times R_{th(j-c)}_{IGBT}$$

$$T_{(FRD_junction)} = T_{(heat_sink)} + Power_FRD \times R_{th(j-c)}_{Diode}$$

Understanding IGBT Data Sheet Parameters White Paper



Bourns® BID Series IGBTs

WHAT ARE TRENCH GATE, FIELD STOP AND PUNCH-THROUGH, AND WHY DO THEY MATTER?

Armed with an understanding of the important parameters and considerations in selecting IGBT technology, a recap will close the loop on the impact the internal structure has on the device. Bourns® IGBTs are made with advanced Trench Gate Field Stop technology to provide power transistors with advanced and beneficial parameters for designing efficient and robust power switching applications.

When evaluating IGBTs for a given design, a field stop (FS) IGBT provides lower saturation voltage drop $V_{ce(sat)}$ and lower switching losses, as evidenced by the very low gate charge Q_g , versus the conventional non-punch-through (NPT) IGBT. The trench gate is a new arrangement of the gate electrode, extending it vertically into the substrate as illustrated in Figure 9 instead of forming it flat on the surface. This allows each single cell of the IGBT structure to be narrower. The result is a different turn-'OFF' behavior with the internal current-carrying mechanism extinguishing faster with less charge required to be extracted. This effect is maximized at high supply voltages near the maximum limit of V_{ces} . The addition of the field stop layer prevents a saturated current conduction, and therefore, contributes to faster turn-'OFF' by suppressing the tail current.

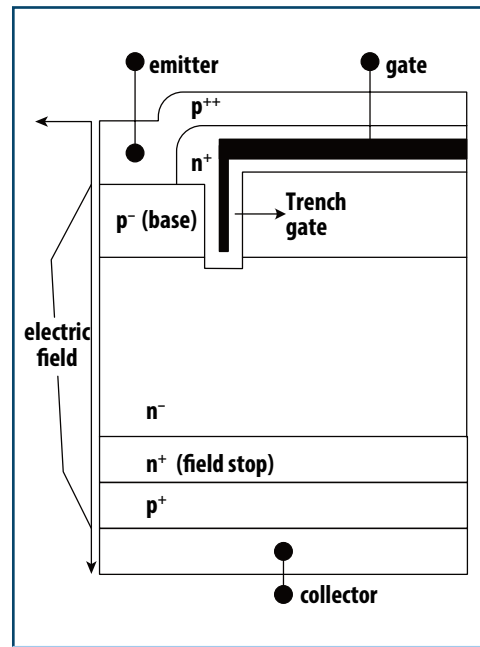

Figure 9. | Diagram of the Formation of the Trench Gate and Field-Stop Layer in the IGBT Die

Understanding IGBT Data Sheet Parameters White Paper



Bourns® BID Series IGBTs

TAKE IT TO THE DATA SHEETS

Clearly there is more to selecting an optimal switching component solution than examining one or two parameters. To achieve truly efficient operation in high voltage, high current applications, it is important to consider many factors. The information in this white paper is meant to deconstruct the characteristics of an IGBT and provide basic information in order to give designers greater insight into the operation of the [IGBT](#).

As a leader in developing component technologies, Bourns' new Trench Gate Field Stop technology-based IGBTs deliver enhanced application efficiencies. With more detailed knowledge of the IGBT parameters outlined in data sheets, designers can better scrutinize the IGBT features that are most appropriate for their specific application. This background makes the navigation of the Bourns IGBT data sheets a more straightforward process and is meant to be a helpful reference when evaluating the type of technology that will best fit the goals of a particular design.

www.bourns.com

BOURNS®

Americas: Tel +1-951 781-5500
Email americus@bourns.com

EMEA: Tel +36 88 885 877
Email eurocus@bourns.com

Asia-Pacific: Tel +886-2 256 241 17
Email asiacus@bourns.com

COPYRIGHT © 2022 • BOURNS, INC. • 08/22 • e/ESD2238

"Bourns" is a registered trademark of Bourns, Inc. in the U.S. and other countries.