

## Resistance Measurement for Bourns® Metal Current Sense Products

### INTRODUCTION

Bourns® metal current sense resistors are popular devices used to measure current flow. When evaluating these products for a given application, designers will need to test their resistance value. To be assured of obtaining a correct reading when testing the resistance, it is important to employ the proper test method for the most accurate results.

Resistance value measurement tests typically use standard multimeters with two measuring wires. This measurement method is suitable for resistance values higher than 10 ohms, but is more prone to inaccurate results when measuring lower resistance values. This is especially true of current sense resistors with resistance values under 100 milliohms. Measuring resistance values less than 1 ohm requires the tester to apply a four-wire (Kelvin) measurement method.

## Resistance Measurement for Bourns® Metal Current Sense Products

### TWO-WIRE METHOD FOR RESISTANCE VALUES GREATER THAN 10 OHMS

Most digital multimeters will use a two-wire method to measure resistance. These ohmmeters provide a current source, force constant current through the component under test, measure the voltage drop and calculate the resistance value based on Ohm's law:

$$R_{\text{subject}} = V_{\text{drop}} / I_{\text{source}}$$

The disadvantage of this method is that not only the resistance of the component ( $R_{\text{subject}}$ ) but also the total resistance of the circuit is measured. This method provides the total resistance of the measuring cables, connectors, fixtures and clips and is typically 5 to 100 milliohms, which is incorrectly added to the measured result.

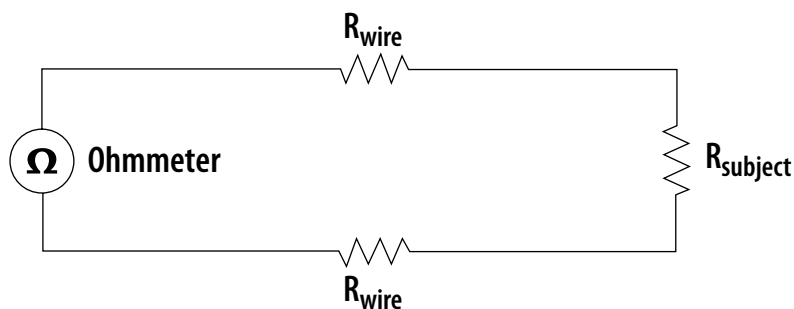

$$R_{\text{measured}} = R_{\text{wire}} + R_{\text{subject}} + R_{\text{wire}}$$

This method is only suitable for measuring resistance values above 10 ohms as the resistance value being measured is much higher than the typical resistance of the measuring wire.

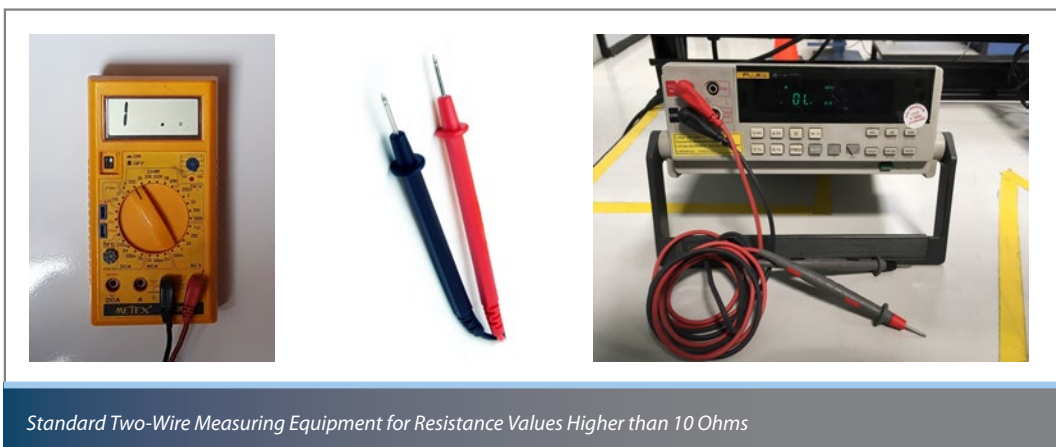

Standard Two-Wire Measuring Equipment for Resistance Values Higher than 10 Ohms

This method is also sensitive to contact probe failure or cable failure, and will introduce additional errors if those problems exist. The measurement of lower resistance values under 10 ohms using this method likely will be inaccurate, especially for metal strip current sense resistors with resistance ranges of 50 micro ohms to 100 milliohms. Therefore, with this method the lower the resistance value being measured, the more inaccurate the measurement results.

For example, if a Bourns® Model CRA2512-FZ-R100 (100 milliohms) metal strip current sense chip resistor is measured with a pair of 40 milliohm measuring cables, the measurement is typically inaccurate by about 40 percent. Bourns does not recommend that customers use this type of measurement method for product inspection or product acceptance.

## Resistance Measurement for Bourns® Metal Current Sense Products

### PROPER FOUR-WIRE METHOD FOR RESISTANCE VALUES LESS THAN 10 OHMS

For measuring resistances under 100 ohms, it is recommended to use the four-wire (Kelvin) method in order to eliminate inaccuracies caused by the resistance of the measuring wires. By using a four-wire connection, the test current (main current) is forced through the component under test via a pair of wires while the voltage drop across the subject component is measured through another pair of cables (sense current).

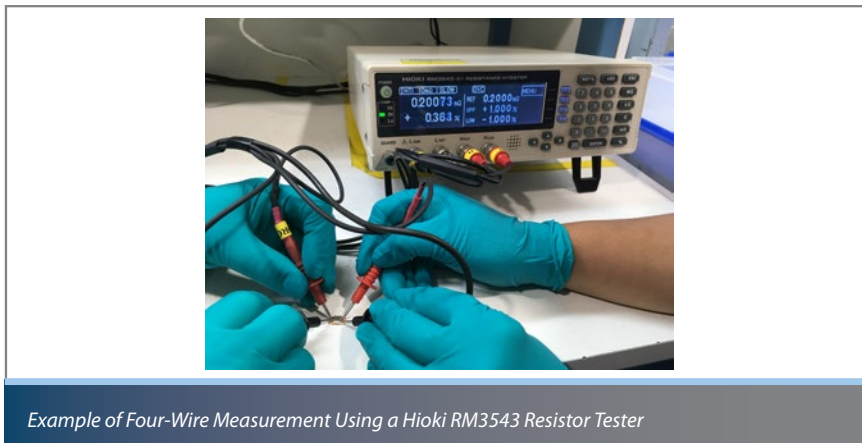
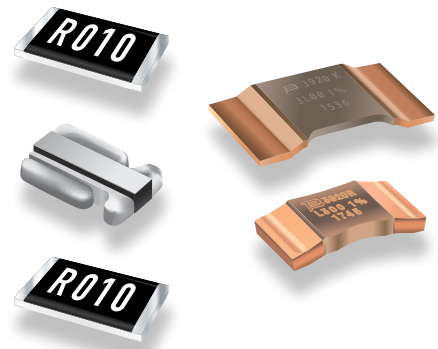
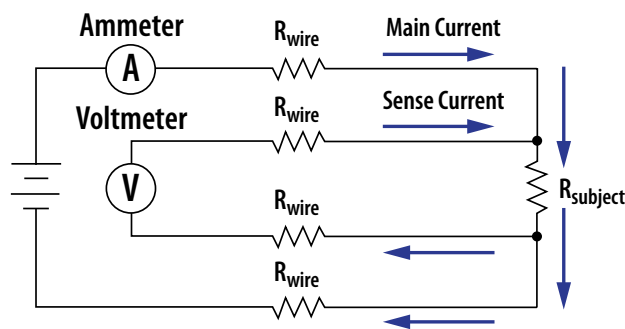

Since the voltmeter internal resistance trends to infinite, the measuring current is very small, typically 10 to 100 pA. Thus, the voltage drop on the current sense wire is very low compared to the voltage drop on the subject component forced by the main current. This is the reason that the resistance of the current sense wire has no significant influence on the measuring result.

Another advantage of using the four-wire method to measure resistance, is that it also helps to prevent the influence of any damaged wires or probes on the resistance measurement.

## Resistance Measurement for Bourns® Metal Current Sense Products

### STANDARD MEASURING POINTS & MEASURING METHOD FOR BOURNS® CURRENT SENSE RESISTORS

Bourns specifies the four-wire (Kelvin) connection method to measure low ohmic current sense resistors. For Model CRA/CRE/CRF2512 metal strip chip resistors Bourns uses four standard measuring points on the bottom side of the terminals.

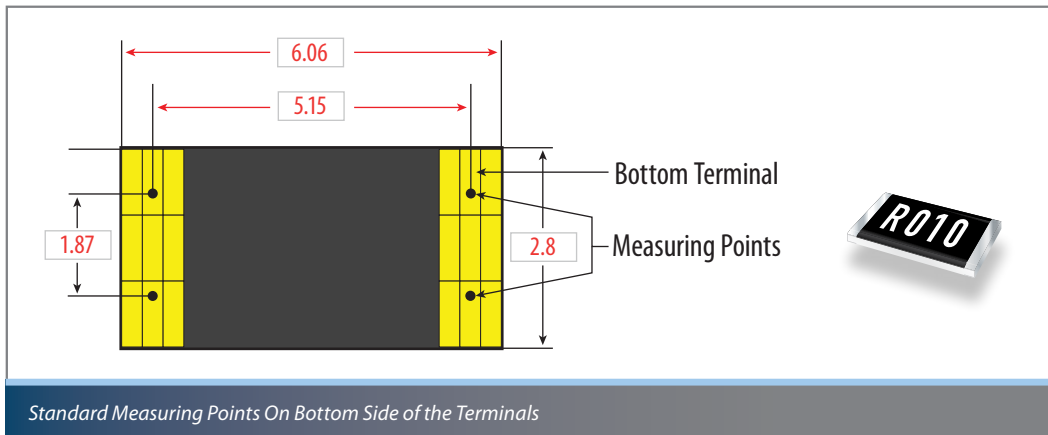

For the low resistance measurement Bourns uses a four-wire jig, which helps ensure that components are measured on the standard measuring points.



## Resistance Measurement for Bourns® Metal Current Sense Products

### STANDARD MEASURING POINTS & MEASURING METHOD FOR BOURNS® CURRENT SENSE RESISTORS (CONTINUED)

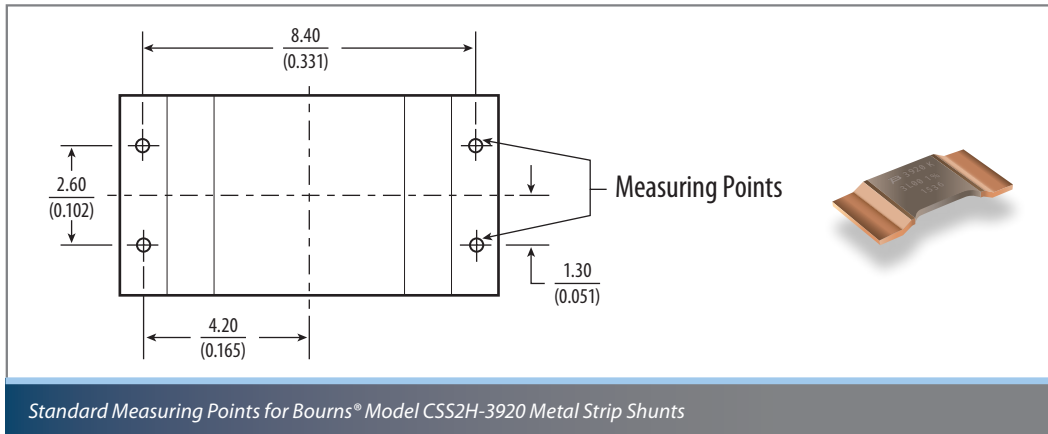

## Resistance Measurement for Bourns® Metal Current Sense Products

### STANDARD MEASURING POINTS & MEASURING METHOD FOR BOURNS® CURRENT SENSE RESISTORS (CONTINUED)

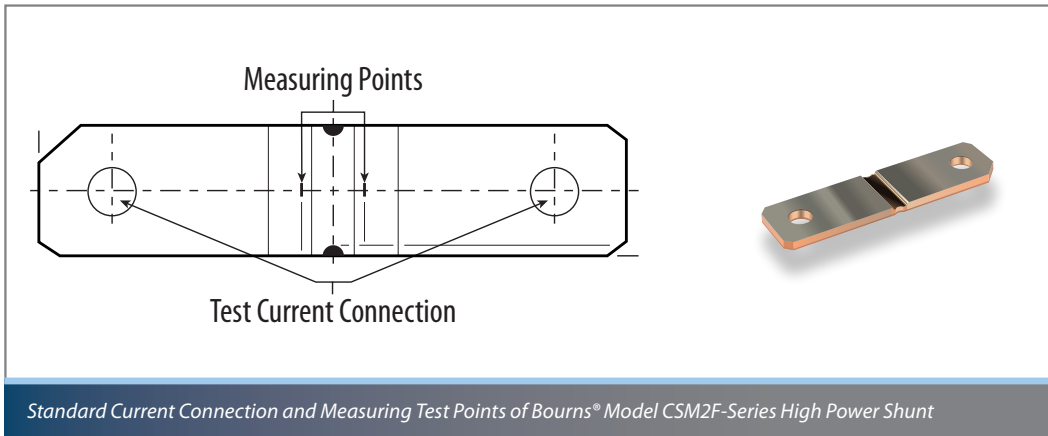

Bourns uses a Hioki RM3543 measuring instrument for metal strip current sensing resistors which is suitable down to  $\mu\text{ohm}$  level.

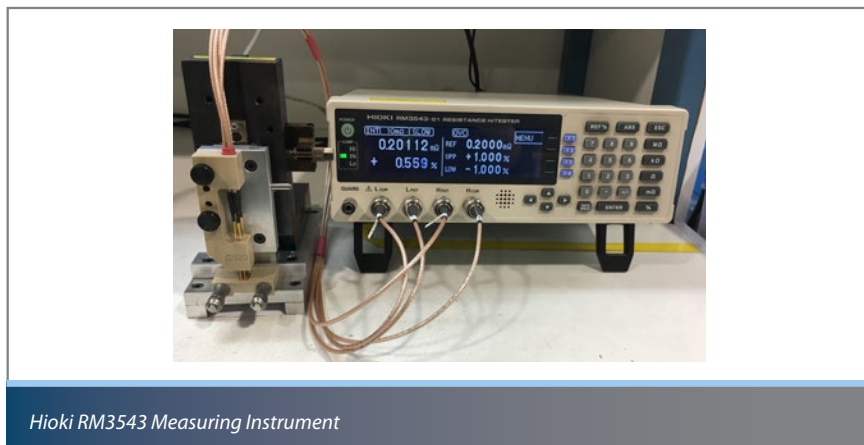

## Resistance Measurement for Bourns® Metal Current Sense Products

### CONCLUSION

Bourns recommends using the four-wire (Kelvin) measurement method for current sense resistors  $R < 10$  ohms. The Bourns® Current Sense Resistor offering is shown below.

Product Series	Image	Technology	Resistance/Value/Range
CRL		Thick Film	10 milliohms to 9.1 ohms
CRM (A)		Thick Film	47 milliohms to 1 megohm
CFN		Metal Film	5 to 20 milliohms
CFG		Metal Film	5 to 10 milliohms
CRF		Metal Strip	1 to 50 milliohms
CRE		Metal Strip	1 to 9 milliohms
CRA		Metal Strip	10 to 100 milliohms
CRK		Metal Strip (Wide Terminals)	1 to 10 milliohms
CST		Metal Strip (4 Terminals)	0.5 to 5 milliohms
CSS		EB-Welded Metal Strip	0.2 to 5 milliohms
CSM		EB-Welded Metal Strip	0.05, 0.1 milliohms

[www.bourns.com](http://www.bourns.com)

**BOURNS®**

Americas: Tel +1-951 781-5500  
Email [americus@bourns.com](mailto:americus@bourns.com)

EMEA: Tel +36 88 885 877  
Email [eurocus@bourns.com](mailto:eurocus@bourns.com)

Asia-Pacific: Tel +886-2 256 241 17  
Email [asiacus@bourns.com](mailto:asiacus@bourns.com)