

# APPLICATION NOTE

## Component Solutions to Help Meet Automotive CO<sub>2</sub> Emissions Reduction

### Using High Power Inductors and Current Sense Resistors for Micro Hybrid Vehicle DC/DC Converters



*Model PQ Series  
High Power Inductors*



*Model CSS2H Series  
Current Sense  
Resistors*

#### INTRODUCTION

In the drive to reduce CO<sub>2</sub> emissions, automotive companies are deploying innovative methods to meet these environmental demands. A promising vehicle type in this area is the micro hybrid, which uses a stop-start system and regenerative braking to help achieve the desired reduction in CO<sub>2</sub> emissions.

For micro hybrid applications, a 48 V starting motor can restart the engine quicker than a 12 V starter. That is why many micro hybrid vehicles use a combined 48 V starter / generator. This requires a DC/DC converter to efficiently change alternator output voltage from 48 V to 12 V in order to charge the battery. A DC/DC converter is also needed to convert the battery voltage from 12 V to 48 V in order to drive the starter motor.

High powered inductors and current sense resistors that can provide the very low DC resistance ( $R_{dc}$ ) characteristics needed for power conversion and supply requirements are important for efficient DC/DC converter designs in automotive applications. This application note will illustrate a micro hybrid design that uses Bourns® Model PQ series high power inductors that are designed to handle high current levels in a compact form factor, making them ideally suited for these types of applications. Also included is an optimal solution for sensing current measurement with Bourns® Model CSS2H series current sense resistors.

# APPLICATION NOTE

## Component Solutions to Help Meet Automotive CO2 Emissions Reduction

### Using High Power Inductors and Current Sense Resistors for Micro Hybrid Vehicle DC/DC Converters



Model PQ Series  
High Power Inductors



Model CSS2H Series  
Current Sense  
Resistors

### STOP-START SYSTEM BASICS

A regenerative braking system only charges the battery when the vehicle is free-wheeling, braking, or decelerating. During acceleration the alternator is decoupled from the drivetrain, contributing to improved fuel economy and enhanced acceleration as all of the engine's power is driving the wheels. Conventional alternators charge the battery whenever the engine is running.

Stop-start systems are designed to lessen the amount of time an engine idles to thereby reduce fuel consumption and associated emissions, which can be considerable in vehicles that travel in heavy traffic or in urban areas with multiple traffic lights.

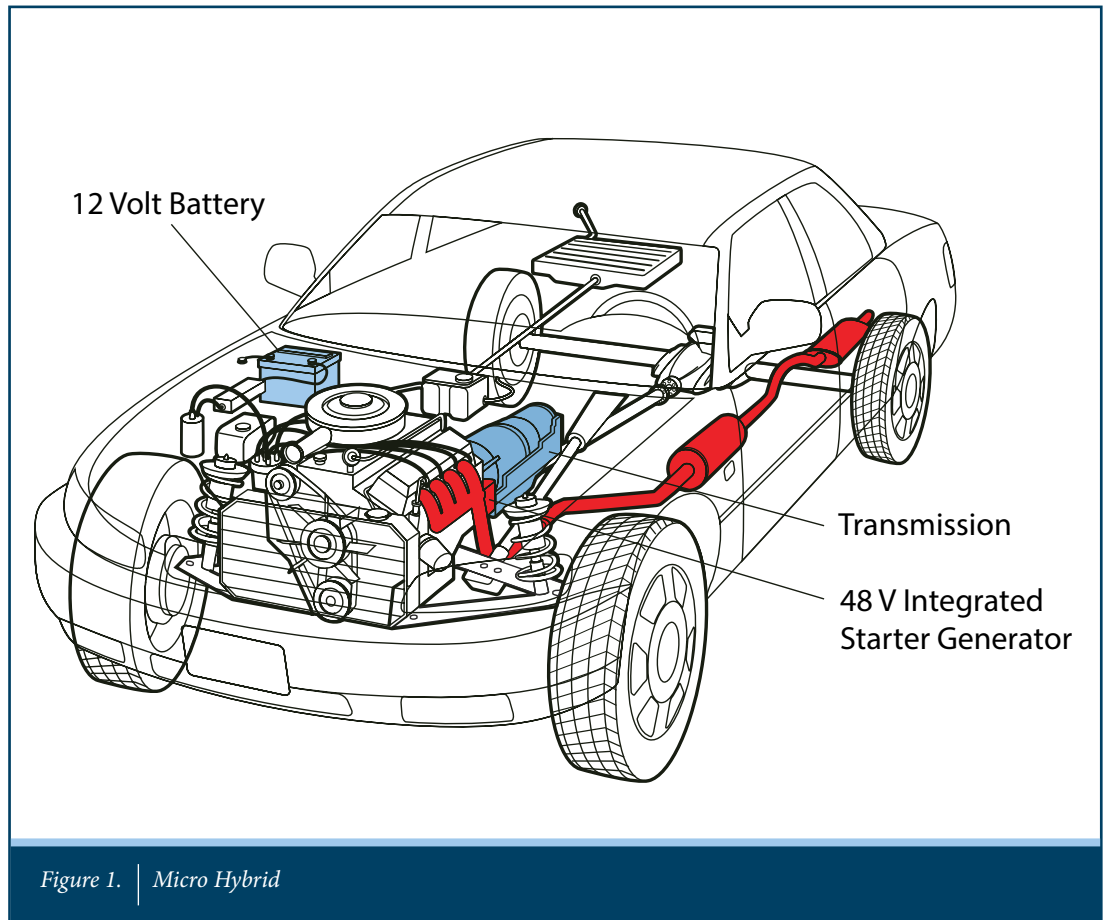

Figure 1. | Micro Hybrid

# APPLICATION NOTE

## Component Solutions to Help Meet Automotive CO2 Emissions Reduction

### Using High Power Inductors and Current Sense Resistors for Micro Hybrid Vehicle DC/DC Converters



Model PQ Series  
High Power Inductors



Model CSS2H Series  
Current Sense Resistors

### HIGH-POWER CONVERTER DESCRIPTION

DC/DC converters in these applications are high power, rated at 1 - 3 kW and implementation is best served by using a multiphase converter due to higher efficiency (> 90 %) from lower switching losses (< 500 kHz), lower input and output ripple currents, reduction of hotspots on the PCB or individual components, lower power rated inductors and Field Effect Transistors (FETs).

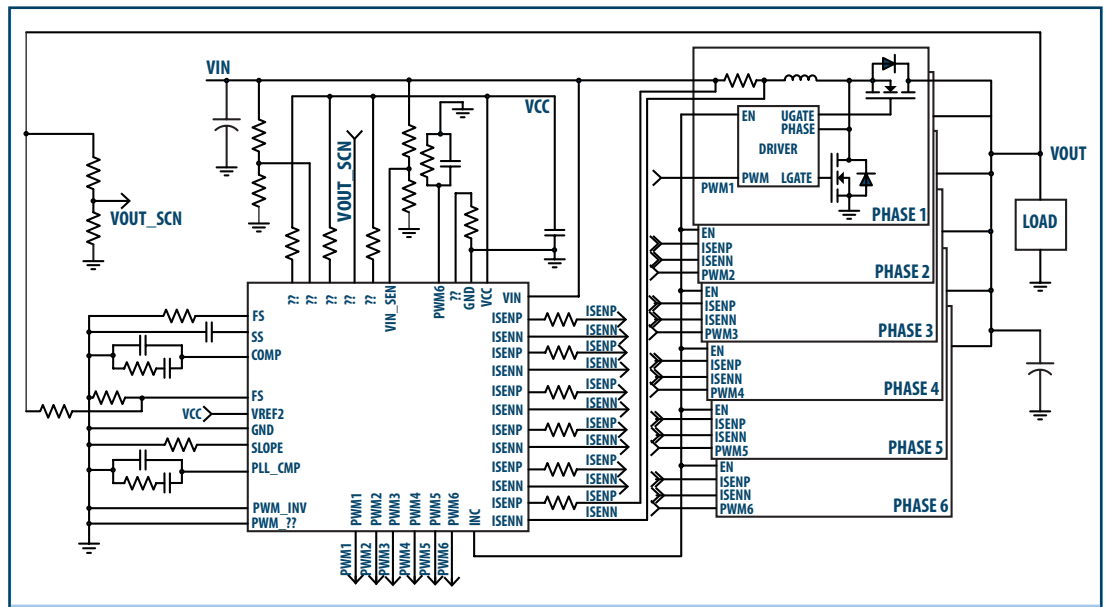

Figure 2. | 6-Phase Synchronous Buck Boost Converter  
with 1 Inductor / Phase and a Current Sense Resistor

The inductor is the energy storage device for all switching converters. The energy stored is calculated:

$$E = \frac{1}{2} LI^2 \text{ (Joules) - } I \text{ is the inductor current and } L \text{ is the inductance.}$$

The variation of inductor current during the switcher operation is known as ripple current and its amplitude is determined by the value of inductance. Ripple current is usually kept below 30 % of the output current in order to reduce AC and core losses.

$$V_1 = L di/dt - V_1 \text{ is the voltage across the inductor - } di \text{ is the ripple current and } dt \text{ is inversely proportional to the switching frequency.}$$

# APPLICATION NOTE

## Component Solutions to Help Meet Automotive CO2 Emissions Reduction

### Using High Power Inductors and Current Sense Resistors for Micro Hybrid Vehicle DC/DC Converters



Model PQ Series  
High Power Inductors



Model CSS2H Series  
Current Sense  
Resistors

### KEY INDUCTOR SPECIFICATIONS

Key specifications for Bourns® inductor products are  $I_{rms}$  and  $I_{sat}$ .  $I_{rms}$  is the current that causes the inductor temperature to rise by 40 °C and  $I_{sat}$  is the current that causes the inductance to decrease by 10 - 30 %.

The current in a switching converter is rarely stable, and the variation will be the result of transients, spikes, or sudden load and supply changes. The fall-off of inductance with increasing current is an important characteristic.

Helping to remedy these issues is the Bourns® Model PQ series, which is produced with ferrite and features an air gap. These features help keep the value inductance relatively stable with increasing current until the core saturates resulting in a sudden collapse of the inductance. Designed with a flat wire winding, the AEC-Q200 compliant Model PQ series inductors deliver a compact solution with exceptionally low DC and AC resistance and high saturation current handling of over 100 Amps.

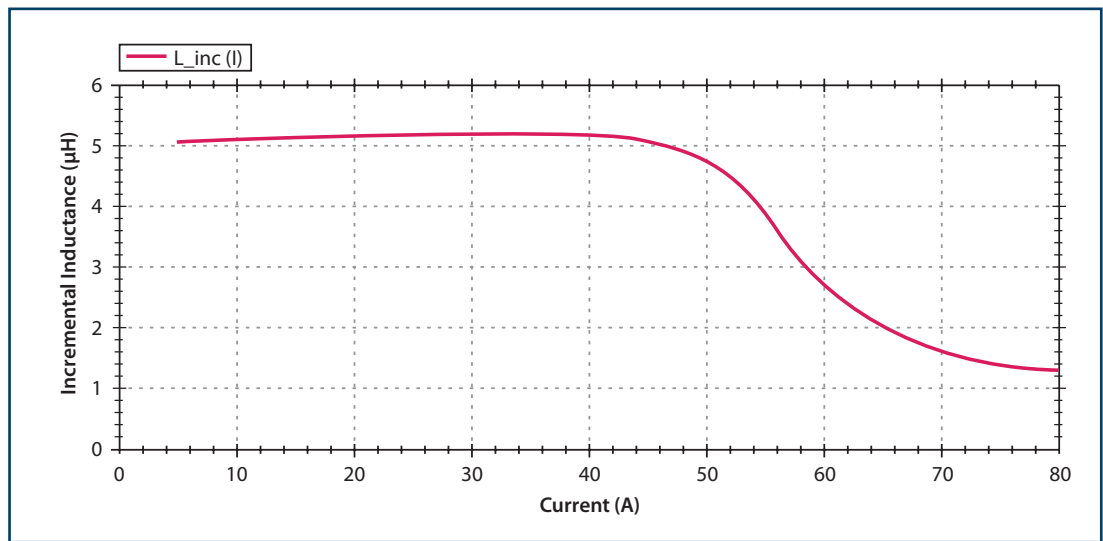

Figure 3. | The Model PQ series products offer a high operating temperature specified at 150 °C

# APPLICATION NOTE

## Component Solutions to Help Meet Automotive CO2 Emissions Reduction

### Using High Power Inductors and Current Sense Resistors for Micro Hybrid Vehicle DC/DC Converters



Model PQ Series  
High Power Inductors



Model CSS2H Series  
Current Sense  
Resistors

### SENSING VOLTAGE MEASUREMENT

An important element of a micro hybrid DC/DC converter application design includes measurement of the sensing voltage, ( $V_{\text{sense}}$ ). Devices are used to sense input current continuously by measuring the voltage across a dedicated current sense resistor. Current sensing provides necessary precision channel-current balancing, and per-phase overcurrent protection. Current sense resistors are gaining in popularity due to their high measurement accuracy and relatively low cost compared to other technologies.

To determine the inductor current, designers can use the following equation:

$$V_{\text{sense}} = I_o \times R_{\text{sense}}$$

Typically, in this type of application,  $V_{\text{sense}}$  will be set to 100 mV to save power and, at the same time, keep the voltage level high enough above the noise. To sense a 250 A average output current, for example,  $R_{\text{sense}}$  must be  $100 \text{ mV}/250 \text{ A} = 0.4 \text{ m}\Omega$ .

As the voltage drop generated by the current is quite low, it is important that error voltage is minimized. Sources of error voltages include thermal electromotive force (EMF), voltage drop on leads and induced voltages due to inductance. Error voltages can be kept to a minimum by careful selection of resistive lead frame materials and tight process control.

An optimal sensing voltage solution for micro hybrid DC/DC applications is the Bourns® Model CSS2H current sense resistors. Helping developers save energy while maximizing sensing performance in their designs, the Model CSS series features low Temperature Coefficient of Resistance (TCR) down to 0.0002 ohms for operating accuracy over wide temperature ranges and excellent long-term stability. Addressing extended temperature automotive requirements, they offer a wide operating temperature range (-55 to +170 °C), low thermal EMF and high current handling up to 120 Amps.

## APPLICATION NOTE

# Component Solutions to Help Meet Automotive CO2 Emissions Reduction

### Using High Power Inductors and Current Sense Resistors for Micro Hybrid Vehicle DC/DC Converters



*Model PQ Series  
High Power Inductors*



*Model CSS2H Series  
Current Sense  
Resistors*

## BENEFITS FOR MICRO HYBRID DESIGNS

Helping to ensure a more efficient converter design, Bourns® Model PQ series inductors deliver the very low  $R_{dc}$  necessary to reduce DC losses. They also offer stable inductance over a wide range of currents while meeting the high operating temperature (150 °C) requirements of many automotive applications. Its flat wirewound design provides a compact inductance solution that is particularly well-suited for automotive power conversion applications such as the micro hybrid vehicle. Boosting the overall efficiency of DC/DC converters, the Model PQ series inductors feature low power dissipation combined with the low core loss nature of their ferrite core construction. In addition, these devices are mounted on a plastic base designed with an extra solder pad for increased mechanical stability.

The Bourns® Model CSS2H current sense resistors represent a new generation of high power current sense resistors that match designers' needs for an accurate device in higher power applications. In micro hybrid vehicle designs, they are key components in monitoring a voltage drop across the sense resistor and converting it to a current reading to assist in the efficient operation of the circuit.

Bourns continues to be a leader in offering enhanced solutions for high frequency, high current start-stop automotive applications through its extensive portfolio of approximately 2,000 inductors. Designers can select from a broad range of flat wire conductors and powdered iron cores that are molded directly to the wire in a wide range of inductance values.

[www.bourns.com](http://www.bourns.com)

# BOURNS®

**Americas:** Tel +1-951-781-5500  
Email [americus@bourns.com](mailto:americus@bourns.com)

**EMEA:** Tel +36 88 520 390  
Email [eurocus@bourns.com](mailto:eurocus@bourns.com)

**Asia-Pacific:** Tel +886-2 256 241 17  
Email [asiacus@bourns.com](mailto:asiacus@bourns.com)

COPYRIGHT© 2018 • BOURNS, INC. • 04/18 • e/K1824

"Bourns" is a registered trademark of Bourns, Inc. in the U.S. and other countries.