

Current Limiting Power Resistors for High-Power LED Module Lighting Applications

PWR263



An ongoing trend toward miniaturization of virtually all electronics is accompanied by the demand for a reduction in power consumption. As the pressure to fit as much functionality, and thus circuitry, into the smallest space possible continues to rise, so too do the challenges of the associated thermal design. One technology that has been gaining the attention of commercial and consumer customers alike is the light emitting diode (LED). LEDs are an extremely versatile and compact alternative to the traditional incandescent bulb with versatility to extend to applications where incandescent lighting previously was not possible. Savings in long term operation and energy costs while utilizing a robust package are just a couple of advantages that have made LEDs popular. However, what may not be overlooked as this efficient technology disperses into lighting designs everywhere, is the importance of temperature and thermal management in providing a reliable LED design, especially in high power LED modules. Methods to address the thermal challenges in high-power LED modules are introduced in this paper as are the advantages of integrating the Bourns® PWR263 power resistor in LED module designs.



Reliability and Temperature

The reliability of a system such as an LED module can be impaired dramatically by an increase in temperature. Due to the inherently low internal resistance of an LED, it is necessary to use external means to limit the current to which it is exposed. Otherwise the LED will burn up rather quickly on its own, causing low reliability of the system.

Case temperature is another factor in the LED module thermal design. Like other semiconductors such as power transistors, power LEDs can have high power ratings. However, these components are intolerant of high case temperatures. In addition to reducing the lifetime of an LED, high case temperatures reduce the component's mean time between failure (MTBF). Unless there is a strong air-cooling system in the immediate proximity, an axial leaded resistor will heat up since it has no path for transferring the heat generated in operation. Power LED modules are used in many products where a cooling system is not possible such as in portable battery powered equipment, so an alternate thermal solution is imperative.

Temperature also presents danger to the LED internally. The junction in an LED can overheat when the current through it exceeds its optimal value. If the junction overheats, the LED plastic housing could melt and the internal bonding of the LED may become damaged. Therefore, LED modules must employ some type of control to ensure that the current remains within the appropriate limits.



Current Limiting

Three key factors determine the limits to which the operating current of the LED must be controlled. First is the specification of the LED itself. Second is the application in which the LED is being used. Finally, the specifications of the LED system must be considered.

Some specifications require that the temperature of the components used in LED modules does not exceed certain limits. This protects the LEDs from additional sources of heat which could further reduce the lifetime of the LED. These limits are in place for regulatory purposes as well. For example, temperature controls are very important in environments such as chemical plants where explosion is a serious and ongoing threat.

One simple method to control the current within LED modules is to use a single resistor to limit the forward current. Consider a system typical in an industrial or automotive application. As illustrated below it includes a standard low cost 12 V regulator and a string of two LEDs each with a forward voltage of 2.0 V. The diode current in this case is 0.3 A (I_{diode}). Basic circuit analysis can be performed to determine key parameters of the resistor in the circuit: voltage, resistor value, and power.

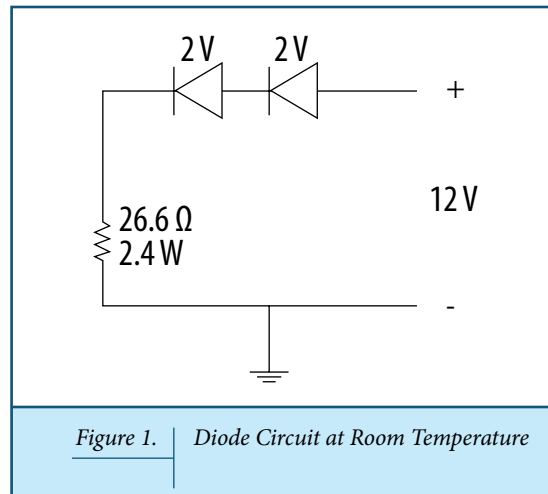

$$V_{\text{resistor}} = V_{\text{supply}} - n * V_{\text{diode}} = 12 \text{ V} - 2 * 2.0 \text{ V} = 8.0 \text{ V}$$

$$R_{\text{resistor}} = V_{\text{resistor}} / I_{\text{diode}} = 8.0 \text{ V} / 0.3 \text{ A} = 26.6 \text{ Ohm}$$

$$P_{\text{resistor}} = V_{\text{resistor}} * I_{\text{diode}} = 8.0 \text{ V} * 0.3 \text{ A} = 2.4 \text{ W}$$

The resistor will have a voltage drop of 8 V, which results in a 26.6 ohm resistor that dissipates 2.4 W.



The Effect of Temperature on Power

The previous example assumes the system is operating at a constant temperature. However, since the forward voltage of LEDs is dependent on temperature, any increase in the ambient temperature will cause the voltage to drop. For instance, if an LED has a temperature coefficient of $-5 \text{ mV}/^\circ\text{C}$ and the ambient temperature inside the LED module increases by 50°C , then the forward voltage will drop by 0.25 V . If there are two LEDs in the string then both are taken into account for a total drop of 0.5 V . Applying this temperature shift to the previous example illustrates the effect on the system.

$$\begin{aligned} V_{\text{resistor}} &= V_{\text{supply}} - 2 * V_{\text{diode}} = 12 - 2 * 1.5 \text{ V} = 9 \text{ V} \\ R_{\text{resistor}} &= V_{\text{resistor}} / I_{\text{diode}} = 9.0 \text{ V} / 0.3 \text{ A} = 30 \text{ Ohm} \\ P_{\text{resistor}} &= V_{\text{resistor}} * I_{\text{diode}} = 9.0 \text{ V} * 0.3 \text{ A} = 2.7 \text{ W} \end{aligned}$$

The power dissipated therefore increases to 2.7 W .

Another consideration in thermal design is the production variations in the LED forward voltage, which could be $\pm 0.3 \text{ V}$. Based on this variation the power dissipated in the same 30 ohm resistor could be even higher.

$$\begin{aligned} V_{\text{resistor}} &= V_{\text{supply}} - 2 * V_{\text{diode}} = 12 - 2 * 1.2 \text{ V} = 9.6 \text{ V} \\ P_{\text{resistor}} &= 9.6 * 0.3 = 2.88 \text{ W} \end{aligned}$$

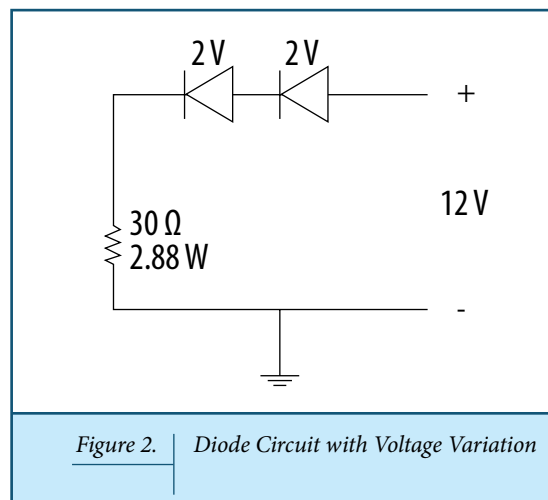

Figure 2. Diode Circuit with Voltage Variation

Special consideration must be given to these factors during the design of an LED module to avoid permanent damage to the LEDs themselves.



Voltage Regulation

Another method to control the current in an LED module is through use of a regulator. As a safety precaution for changes in forward voltage, voltage regulation circuits require LEDs to be driven below their maximum current. Oftentimes this requires additional LEDs to meet the specifications of the system, thus increasing costs. Using constant current control rather than a voltage regulator can be a more cost-effective solution since a linear constant current regulator requires very few external components to operate.

The following circuit example consists of a voltage regulator chip and an LED string. In this example the output from the chip is 12 V. A reference voltage provided by a power resistor enables a constant 12 V output and constant current of 0.3 A with feedback through the LED string. The resistor ensures a constant current within rated limits. Assuming a voltage drop of 3.4 V across the diodes due to production variations in the forward voltage, a 30 ohm resistor which can dissipate 2.6 W is needed.

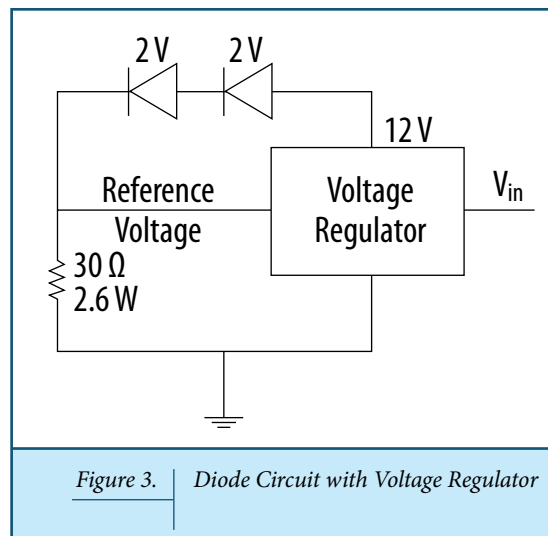

Figure 3. Diode Circuit with Voltage Regulator

Temperature Control and PWR263S-20



The choice of a current limiting resistor for an LED module should also take into account what limits are imposed by the design on the maximum temperature of the resistor when it is under load. Surface mount resistors capable of handling high power levels without generating high temperatures are becoming more available on the market. Advances in manufacturing techniques and new materials have contributed to making these components increasingly more cost-efficient.

Bourns offers a family of power resistors that meets the needs of thermal issues in high-power LED modules. The Bourns® Model PWR263S-20 can dissipate 20 W on an infinite heat sink. On a standard FR4 printed circuit board, 3 to 4 W can be dissipated provided ample copper is available around the resistor. Bourns uses insulated metal substrates (IMS), which are thermally conductive printed circuit boards, to enable the PWR263S-20 to dissipate even more power while keeping the surface temperature of the printed circuit board at an acceptable 85-90 °C. In addition, the Bourns® Model PWR263S-20 is RoHS compliant* and is compatible with lead free reflow soldering temperatures. For ease of design and manufacturing, the packaging is compliant with the familiar JEDEC D2PAK standard.

The following diagram illustrates the thermal behavior of a PWR263S-20 mounted on a surface and broken down into equivalent thermal resistances. Originating with the resistive element itself and ending with the mounting surface, there are four individual thermal resistances. The data sheet of the PWR263S-20 indicates that the overall thermal resistance of the component is 6.5 °C/W ($R_{th1} + R_{th2}$). The hottest part of the component, represented by T_j , is where the resistive film lies. From T_j the heat travels downward through the metal backplate, which helps to conduct the heat quickly, and into the solder paste and the mounting surface. The temperature of the mounting surface will depend on its thermal resistance which is affected by the materials used.

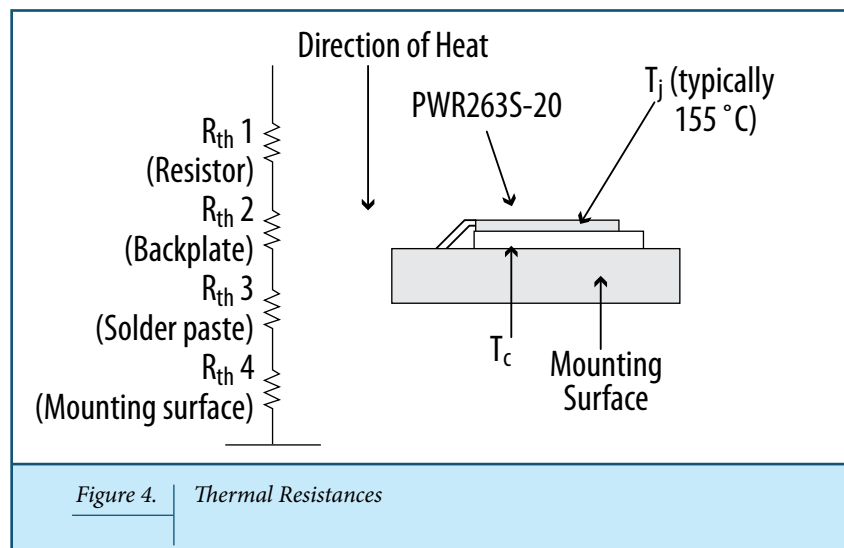



Conclusion

High-power LED modules are being used increasingly in portable applications where the design specification calls for a control of the surface temperature of the components. LEDs have a much longer life span than traditional incandescent light bulbs as long as the temperature is adequately controlled. It remains essential to consider thermal requirements at the onset of the design in order to create a reliable system. The simplicity of inserting a high power resistor that can limit current and dissipate power is a tremendous advantage, whether used as a standalone solution or combined with a regulator. Thus, an ideal solution for any high power LED module application in which current limiting resistors are part of the design is the Bourns® Model PWR263 power resistor family.

For more information on current limiting power resistors and other products from Bourns, please visit

www.bourns.com

COPYRIGHT © 2009 • BOURNS, INC. • 06/09 • XX/N0928
"Bourns" is a registered trademark of Bourns, Inc. in the U.S. and other countries.

** RoHS Directive 2002/95/EC Jan. 27, 2003 including Annex.*