



16:20	Bristol	EZY6268
16:25	Milan/Malpensa	EZY2794
16:30	Geneva	LX1473
16:45	Dusseldorf	LH3285
16:50	Brussels	SN2312
16:55	Strasbourg	AF4941
16:55	Bratislava	SU1535
17:00	London/Stansted	EZY3068
17:00	Milan/Malpensa	AZ7563
17:00	Copenhagen	OK0508
17:00	Warsaw	KE7667
17:05		



New Open LED Shunt Protection (LSP) Devices Help Prevent High Reliability LED Lighting Application Failures

LSP Series



INTRODUCTION

As LEDs continue to penetrate a wide range of diverse market sectors and become the preferred means of lighting, the requirement for circuit protection cannot be ignored. In many illumination applications, multiple LEDs are connected in series strings to achieve light output comparable to their incandescent or fluorescent counterparts. Some solid-state lighting luminaires are configured in series strings of twenty or more LEDs. In these configurations, one open-circuit LED can cause the entire LED string to go dark, resulting in reduced performance, possible maintenance calls, and costly warranty returns.

As an innovator in circuit protection technology, Bourns has a long history of developing reliable solutions for a broad range of markets and applications. In working with its customers, Bourns realized a critical need for circuit

protection in LED designs that would help them to be more robust and could be integrated with the least amount of impact on the design. Adding Bourns® LSP Series shunt protectors to an LED design allows the healthy LEDs in the string to remain illuminated by shunting current around the inoperable open circuit LED. The new Bourns® LSP Series of open LED shunt protectors is an effective solution for a variety of LED lighting applications including street lighting, high reliability lighting fixtures and backlight signage systems.

This paper was developed to help designers understand common threats to LED lighting systems, and provides the best design practices to implement Bourns® LSP devices as an effective circuit protection solution in LED lighting applications.

HIGH RELIABILITY LED APPLICATIONS

Because of their inherent high reliability, LEDs have become the technology of choice for a broad range of lighting applications. In the consumer market, LEDs are being used for everything from LCD backlighting in televisions and computer monitor displays to specialized lighting applications. LEDs have also been designed into a variety of transportation instrumentation such as dashboard backlighting, avionics signage and vehicle ambient lighting. Industrial lighting applications that require very low maintenance such as streetlights, parking lots and garages, high-bay factory, commercial, and arena lighting all realize the longevity and reliability benefits

of LED technology. Of considerable importance – many of today's LED lighting systems are often sold with warranties that cover the energy and maintenance cost payback period of the particular solution. LED designs need to be robust as premature failures will affect the luminaire manufacturer more than the end customer. These failures could also contribute to delayed adoption of LED technology.

If an LED lighting application requires highly stable and reliable functionality, then it can benefit from Bourns® LSP shunt protection devices.



16:45	Dusseldorf	LH3285
16:50	Brussels	SN2812
16:55	Strasbourg	AF4941
16:55	Bratislava	SU1555
17:00	London/Stansted	EZV3068
17:00	Milan/Malpensa	AZ7563
17:00	Copenhagen	OK0508
17:00	Warsaw	KE7667



LSP Series



New Open LED Shunt Protection (LSP) Devices

Help Prevent High Reliability LED Lighting Application Failures

COMMON THREATS IN LED LIGHTING SYSTEMS

In order to understand the advantages Bourns® LSP devices give to LED lighting circuit protection, it is worthwhile to explore the basic threats to LEDs and the associated failure modes. First, there are four main threats:

- High temperatures are the leading cause of LED failure. Operating at high temperatures will shorten the life of any LED, and can also lead to sudden failures in some circumstances.
- Electrostatic Discharge (ESD) can cause immediate failure of an LED. Usually this results in a shorted device. Some LEDs come equipped with an integral zener diode to raise the damage threshold to perceived acceptable levels. Many LEDs are designed into fixtures so that exposure to ESD is minimized.
- Overvoltage and overcurrent events can be the result of surges that make their way through the power system to the LED strings. Failure modes include both short circuit and open circuit (where LED bond wires are destroyed). Proper circuit protection to prevent surges from propagating through the power system must be designed in accordance with the exposure of the lighting system. For instance, outdoor parking lot lighting atop metal poles have a greater risk of lightning damage than indoor lighting in a warehouse.
- High temperatures can be the result of higher than predicted ambient temperatures, failed cooling fans, blocked ventilation, or installation in improperly ventilated fixtures. Most LEDs are designed to run continuously at no more than 100 °C. The electronics driving the LEDs usually are limited to 50 °C since electrolytic capacitors in the power systems will age more quickly at higher temperatures. Sustained high LED temperatures can lead to shorted LEDs or melting of the optical transparent layer. Cycles through high and low temperatures can weaken the wire bonds prematurely as the plastic encapsulator expands and contracts with temperature.



LSP Series

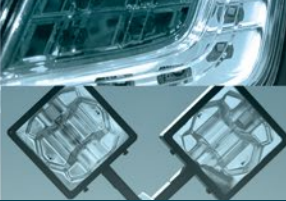

16:45	Dusseldorf	LH3285
16:50	Brussels	SN2812
16:55	Strasbourg	AF4941
16:55	Bratislava	SU1555
17:00	London/Stansted	EZY3068
17:00	Milan/Malpensa	AZ7563
17:00	Copenhagen	OK0508
17:00	Warsaw	KE7667



New Open LED Shunt Protection (LSP) Devices

Help Prevent High Reliability LED Lighting Application Failures

COMMON THREATS IN LED LIGHTING SYSTEMS (Continued)

There are three typical failure modes for LEDs, each shown in figure 1. As an LED ages, the amount of light it emits for a given input power decreases as shown in figure 1a. Once below a certain percentage of its initial value, usually about 70 %, the LED is deemed to be “End of Life”. The lifetime of LEDs is far greater than for fluorescent or incandescent types of lighting, so end of life is typically reached after tens of thousands of hours if operated within its specifications. Secondly, the LED die can be damaged due to overvoltage, overcurrent, or overtemperature conditions. Any of these could result in an LED short failure, as shown in figure 1b. Finally, the wire bond connecting the LED chip to the lead frame may break or burn open as illustrated in figure 1c.

Bourns® LSP devices are designed to protect LED lighting applications in series strings from these open circuit failure conditions. Applications that are best suited for Bourns® LSP circuit protection include those with high current, series string connections, and those with little tolerance to string failure. The LSP series is designed with a minimum breakover current of 75 mA and should not be used in LED applications below this level. LEDs operating at less than 75 mA are less likely to experience open LED failures because they do not generate the high temperatures known to be a major factor in open LED failures.

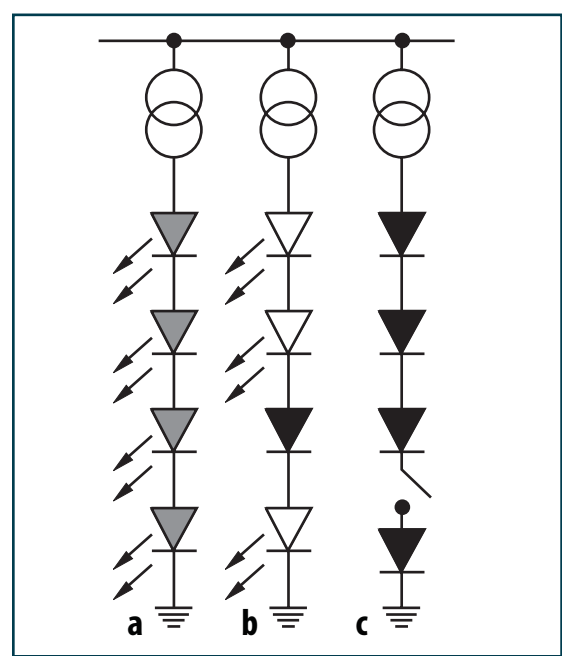
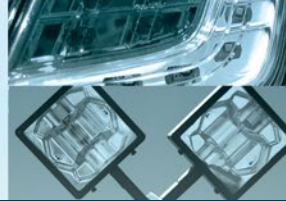

Figure 1. | a) Dim LEDs,
b) Shorted LED,
c) Open LED



16:45	Dusseldorf	LH3285
16:50	Brussels	SN2812
16:55	Strasbourg	AF4941
16:55	Bratislava	SU1555
17:00	London/Stansted	EZV3068
17:00	Milan/Malpensa	AZ7563
17:00	Copenhagen	0K0508
17:00	Warsaw	KE7667



LSP Series



New Open LED Shunt Protection (LSP) Devices Help Prevent High Reliability LED Lighting Application Failures

LED LIGHTING DESIGN CONFIGURATION

Solid-state lighting luminaires are commonly configured with long strings of multiple LEDs in series. There are several benefits to this configuration. LED designs are easily scalable due to the inherent modularity of the compact diodes. For example, using 1 W LEDs allows a designer to easily create an 8 W, 16 W, 24 W or 32 W design from multiple strings of eight 1 W LEDs. An application that demonstrates how this modularity is currently used is with streetlight design that has 90 LEDs configured

as six strings of 15 LEDs. Each string of LEDs is driven by an independent constant current power supply with a relatively high compliance voltage. Multiple LEDs can be arranged in series to simplify the power supply design. High voltage, low current power supplies improve the efficiency of the power supply. Selecting the right power supply and designing it with the appropriate power supply architecture is crucial to reliable operation of the circuit.

PREVENTING LIGHTING STRING FAILURES

To allow the remaining LEDs to continue working in the presence of a single open-circuit LED, an electronic shunt current bypass such as a Bourns® LSP device is required. The LSP provides a means to bridge the open circuit and allows current to flow uninterrupted through the string of LEDs. Bourns® LSP devices employ proven thyristor technology similar to Bourns® TISP® devices. During normal operation of the circuit, there is no current flowing through the device. Only in the event of an open circuit does the Bourns® LSP device become active.

The breakover voltage, $V_{(BO)}$, is proportional to the number of LED chips spanned in a substring. It must be high enough not to clip the forward voltage and be lower than the voltage

that would exist across an open circuit LED when the breakover current, $I_{(BO)}$, is drawn. Whenever the voltage across the device exceeds the rated $V_{(BO)}$, the Bourns® LSP device switches to its on state. In this state, the voltage across the Bourns® LSP device falls to about 1 V. This is less than the typical 3 V forward voltage, V_F , of the operational LED. For a given system current, this will reduce the power at this point in the circuit by approximately 60 %. This power reduction also contributes to lower localized heating that can help prevent further failures. To ensure the Bourns® LSP device switches on reliably, $I_{(BO)}$ is specified below the minimum LED operating current and is high enough to prevent false triggering.



LSP Series

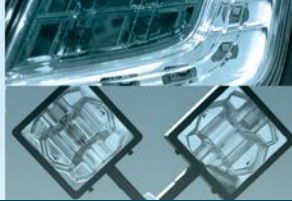

16:45	Dusseldorf	LH3285
16:50	Brussels	SN2812
16:55	Strasbourg	AF4941
16:55	Bratislava	SU1555
17:00	London/Stansted	EZY3068
17:00	Milan/Malpensa	AZ7563
17:00	Copenhagen	0K0508
17:00	Warsaw	KE7667



New Open LED Shunt Protection (LSP) Devices

Help Prevent High Reliability LED Lighting Application Failures

PREVENTING LIGHTING STRING FAILURES *(Continued)*

An unprotected LED and a single Bourns® LSP device are shown in figure 2. Note that the Bourns® LSP device contains a control circuit that triggers the Silicon Controlled Rectifier (SCR), providing a low voltage current bypass for the failed LED to which it is connected. No such bypass is available for an unprotected LED.

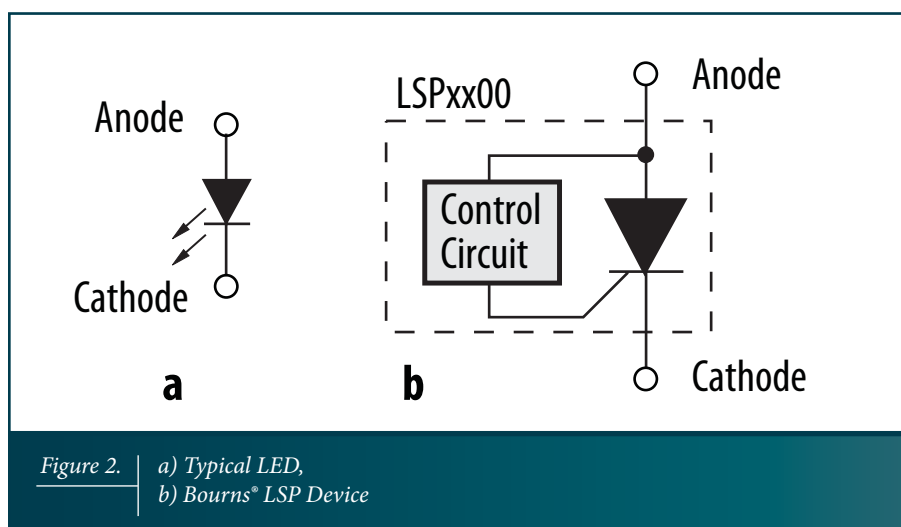

Bourns® LSP devices come in four voltage options designed to protect substrings of one, two, three, or four LEDs. The number of LED chips in a substring is the number of LEDs that will go dark when one of the LEDs in the substring fails. Designs often use multi-chip LED modules so the appropriate Bourns® LSP device should be selected to reflect the number of chips used in each module. Using Bourns® LSP devices to protect a larger number of LEDs helps to minimize design costs. However, the more LED chips in a substring increases the number of LEDs that are affected by a single failure. Bourns® LSP devices are designed with this flexibility in mind to help engineers select the optimal solution that allows them to

balance the cost and failure impacts for each application. Figure 3 shows examples of possible configurations of LEDs that can be protected with Bourns® LSP devices.

Even though some LEDs come equipped with an integral zener diode, this diode is designed to provide only ESD protection for the LED die. These tiny zener diodes are not designed to handle the full operating current of the LED continuously. Furthermore, they are usually connected via the same wire bond as the LED die so that when the wire bond fails, the zener diode typically is disconnected as well. A Bourns® LSP device is still needed to guard against open LED failure.



LSP Series

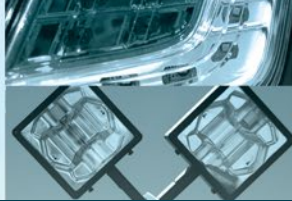

16:45	Dusseldorf	LH3285
16:50	Brussels	SN2812
16:55	Strasbourg	AF4941
16:55	Bratislava	SU1555
17:00	London/Stansted	EZY3068
17:00	Milan/Malpensa	AZ7563
17:00	Copenhagen	0K0508
17:00	Warsaw	KE7667

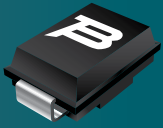

New Open LED Shunt Protection (LSP) Devices Help Prevent High Reliability LED Lighting Application Failures

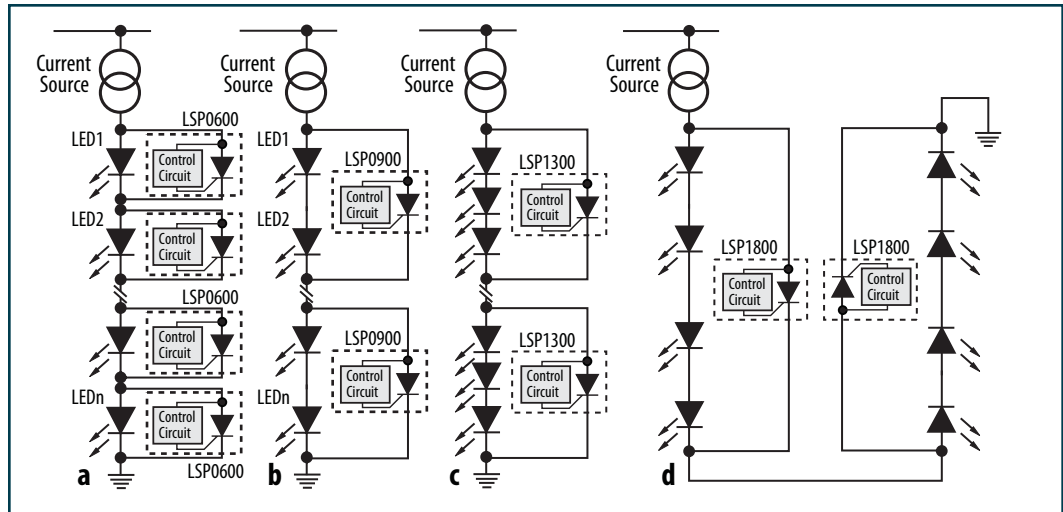

Figure 3. Possible Configurations for LEDs with Bourns® LSP Devices

VOLTAGE AND CURRENT IN LED STRINGS

The interaction between the Bourns® LSP device and the power supply for the LED string dictates the power supply architecture. Proper care must be taken in the design of the power supply architecture to ensure the Bourns® LSP devices operate as intended and the design maintains integrity. LED strings are typically controlled via a constant current source rather than the more conventional constant voltage source for several reasons. Since light output is a function of the current flowing through the LED, each LED in a fixture must be driven at the same current level in order to achieve uniform illumination. The simplest means of achieving this is to connect the LEDs in series and regulate the current that drives them rather than the voltage source. A voltage-current (V-I) curve illustrates the effect of current and voltage variations on the LED.

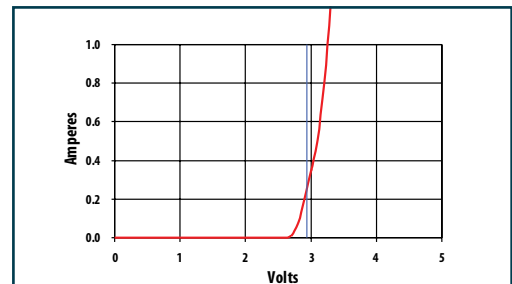
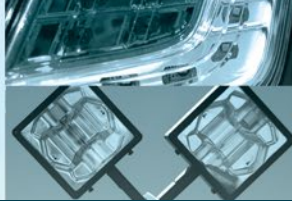

Figure 4. Typical V-I Curve for an LED

Figure 4 shows a typical V-I curve for a 1 W LED. Near the operating point of the LED (350 mA) a current control error of 2 % would cause a mere 7 mA change in LED current and, consequently, a change in brightness. However, a 2 % change in the voltage causes a drastic change in LED current. Arrow “A” below shows the nominal 350 mA while arrow “B” shows the resulting current from a 2 % drop in voltage from the nominal 3 volts. Note that arrow “B” is more than 100 mA below arrow “A”. Such a deviation has significant impact on the brightness of an LED.



LSP Series



16:45	Dusseldorf	LH3285
16:50	Brussels	SN2812
16:55	Strasbourg	AF4941
16:55	Bratislava	SU1555
17:00	London/Stansted	EZV3068
17:00	Milan/Malpensa	AZ7563
17:00	Copenhagen	OK0508
17:00	Warsaw	KE7667



New Open LED Shunt Protection (LSP) Devices

Help Prevent High Reliability LED Lighting Application Failures

VOLTAGE AND CURRENT IN LED STRINGS *(Continued)*

The V-I curve published by the LED manufacturers usually represents only the curve of an ideal part with typical characteristics. However, individual LEDs have curves that shift left or right based on a variety of manufacturing tolerances. Managing this variation has become so challenging that manufacturers offer “binning” services to sort and separate LEDs based on the actual nominal V_f . Each color LED also will have unique V-I curves. The operating temperature also causes a shift in the V-I curve. LEDs often are mounted on a heat-sinking PCB in a matrix arrangement. Due to the variation in temperature, based on the location in the matrix, the corner

LEDs operate at a different temperature than the LEDs in the middle of the matrix, resulting in different V-I characteristics. Thus to produce uniform illumination, current for each string must be controlled separately.

In principle, there is no limit to the number of LEDs that could be connected in one series string. In practice, the maximal voltage available from the power source may be limited by safety, cost, or both. The imposed maximal voltage of the power source may reduce the number of LEDs that could be used in a single string.

COMPLIANCE VOLTAGE FACTOR

The compliance voltage of a constant current power source refers to the range of voltage that it can supply while maintaining the required level of current. For switch mode power supplies, this range can be quite large. When a linear constant current regulator is used to limit current from a DC source, power dissipation often becomes a limitation.

The compliance voltage of the constant current supply is key to a successful LED lighting design. In addition to the supply being capable of providing the operating voltage of the LED string, the designer must factor in the breakover voltage, $V_{(BO)}$ of each Bourns® LSP device used. The Bourns® LSP device is guaranteed to go into full conduction if the maximal $I_{(BO)}$, 75 mA, is available at the maximal breakover voltage of the Bourns® LSP device. The voltage available to drive the Bourns® LSP device into full conduction at the instant an LED goes open must be calculated by analysis.

in figure 4 applies to the design. The operating voltage at 350 mA is 3.0 V, so the power supply during normal operation will have an output of $11 \times 3.0 \text{ V} = 33 \text{ V}$.

If the string experiences a single open LED failure, then the result is 10 LEDs in series with a single Bourns® LSP0600 device. The power supply must be able to deliver at least 75 mA into this load. The curve in figure 4 indicates that at 75 mA, each LED will have a forward voltage of 2.8 V for a total of $10 \times 2.8 \text{ V} = 28 \text{ V}$. In addition to the 28 V required for the LEDs, a $V_{(BO)}$ of 16 V is required momentarily to allow the Bourns® LSP device to trigger. The compliance voltage is $28 \text{ V} + 16 \text{ V} = 44 \text{ V}$. Once the Bourns® LSP device does trigger, it will drop to approximately 1 V. Then the total voltage of the string is given by 10 LED drops plus the Bourns® LSP device drop $(10 \times 3.0 \text{ V}) + 1 \text{ V} = 31 \text{ V}$.



16:45	Dusseldorf	LH3285
16:50	Brussels	SN2812
16:55	Strasbourg	AF4941
16:55	Bratislava	SU1555
17:00	London/Stansted	EZV3068
17:00	Milan/Malpensa	AZ7563
17:00	Copenhagen	OK0508
17:00	Warsaw	KE7667



LSP Series



New Open LED Shunt Protection (LSP) Devices Help Prevent High Reliability LED Lighting Application Failures

GENERAL CALCULATION OF REQUIREMENTS

The preceding example can be generalized and used to calculate the required compliance of the power supply for each string. In normal operation, one to four LEDs on the same string can be grouped into a substring with a Bourns® LSP device. The resulting configuration is “n” substrings of “m” LEDs in a single string of n*m LEDs connected to “n” Bourns® LSP devices. The normal supply voltage across all the LEDs would be:

$$V_{SOP} = n * m * V_{LEDOP}$$

- V_{SOP} is the normal output voltage of the constant current source and
- V_{LEDOP} is the forward voltage of the LED at the normal operating current

This can be rearranged and rewritten as:

$$V_{SOP} = (n-1) * m * V_{LEDOP} + m * V_{LEDOP}$$

When one group of m LEDs goes open, there are (n-1) groups left, and the output voltage must be sufficient to drive the Bourns® LSP device to trigger. That is:

$$V_{STRG} = (n-1) * m * V_{LED75} + V_{(BO)MAX}$$

- V_{STRG} is the supply voltage required to trigger the Bourns® LSP device
- V_{LED75} is the forward voltage of the LED at $I_{(BO)}$ of the Bourns® LSP device
- $V_{(BO)MAX}$ is the maximum $V_{(BO)}$ for the Bourns® LSP device stated in the data sheet

The difference between these voltages is the amount of compliance headroom required for the Bourns® LSP device to operate correctly. This can be expressed as:

$$V_{STRG} - V_{SOP} = (n-1) * m * (V_{LED75} - V_{LEDOP}) + V_{(BO)MAX} - (m * V_{LEDOP})$$

Following this logic with the previous example of 11 LEDs, a second open LED failure in the same string would require a momentary voltage of:

$$(9 * 2.8 V) + (2 * 16 V) = 57.2 V$$

Only the designer can determine if a second failure is likely or worth considering as the compliance voltage is nearly double the nominal output voltage.

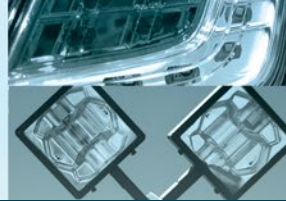

16:45	Dusseldorf	LH3285
16:50	Brussels	SN2812
16:55	Strasbourg	AF4941
16:55	Bratislava	SU1555
17:00	London/Stansted	EZV3068
17:00	Milan/Malpensa	AZ7563
17:00	Copenhagen	0K0508
17:00	Warsaw	KE7667



LSP Series



New Open LED Shunt Protection (LSP) Devices Help Prevent High Reliability LED Lighting Application Failures

POWER SUPPLY ARCHITECTURE: PITFALLS TO AVOID

When designing LED strings with the Bourns® LSP device, known pitfalls must be avoided to achieve consistent and reliable operation. Designers may consider using a simple resistor as an approximation to a constant current supply. The example of the 11 LED string can be used to illustrate the potential problems with this strategy. If the designer selects a 48 V supply to provide the required compliance voltage, the resistor would have to drop 15 V at 350 mA to maintain the 33 V required by the string in normal use. Using Ohm's Law to calculate the specifications of the resistor yields a value of 43 Ω dissipating over 5 W, which would be extremely inefficient. Given that this design uses eleven 1 W LEDs, the dissipation of the luminaire would add to over 16 W and greatly reduce the energy efficiency of the design. Worse, in the event of an open LED, the string voltage would drop to $10 \times 3 = 30$ V for the LEDs plus about 1 V for the Bourns® LSP device. The voltage across the resistor would then be 17 V. The resistor would be driving 396 mA and dissipating 6.7 W, further increasing the inefficiency of the design. This current would overdrive the remaining 10 LEDs and would almost certainly lead to more failures.

Another common pitfall occurs when designers consider driving multiple series strings in parallel from a single constant current source. This strategy relies on V_F variations to “average out” each string so that the strings effectively are matched better than the individual LEDs. This may work with precision binned LEDs as long as the temperatures do not vary between the strings and there are no LED failures. However, this practice would likely not be successful in production. If one LED in one string fails, then the strings would become radically unbalanced. Consider the earlier example of a 90 LED street light design consisting of six strings of 15 LEDs. If each string requires 350 mA nominally, the total current from a single constant current source would be 2.1 A. If one LED fails open

circuit, then the constant current source would drive the five remaining strings with the same total current of 2.1 A, or 420 mA per string. Considering the LED characteristic shown earlier, an increase in 70 mA would result in less than 0.1 V increase across each LED in the string, or a total of less than 1.5 V increase. Since the single Bourns® LSP0600 LED protector requires a minimal $V_{(BO)}$ of 16 V, this will not satisfy the requirement to ensure that the Bourns® LSP device would trip. Similarly, a single LED short would result in a large imbalance in voltage across the remaining die in a string. For the same reasons, it would not be a recommended design where reliable and fault tolerant operation was critical.



LSP Series

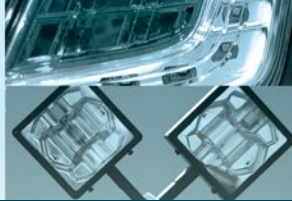

16:45	Dusseldorf	LH3285
16:50	Brussels	SN2812
16:55	Strasbourg	AF4941
16:55	Bratislava	SU1555
17:00	London/Stansted	EZY3068
17:00	Milan/Malpensa	AZ7563
17:00	Copenhagen	OK0508
17:00	Warsaw	KE7667



New Open LED Shunt Protection (LSP) Devices

Help Prevent High Reliability LED Lighting Application Failures

BENEFITS OF BOURNS® LSP DEVICES

Distinct performance and configuration criteria have been introduced that typify appropriate applications for the Bourns® LSP device. Bourns® LSP devices must be used with appropriate power supply architecture to realize the maximum benefit of employing a Bourns® LSP device in an LED lighting system. Following the examples given, each LED string should have its own independent current control.

Bourns has innovatively designed its LSP devices with a low trigger current to ensure it is suitable for the widest range of applications possible. Warranty returns or maintenance calls as a result of LED failure can be costly in terms of money and time, which is especially unfortunate when a single open LED impairs a large portion of the application. This is where Bourns® LSP devices provide a circuit protection solution that leads to greater reliability and increased Mean Time Between Failure (MTBF). When a Bourns® LSP device is connected in a string of LEDs, a single LED failure does not interfere with the operation of the unaffected LEDs and allows the lighting string to continue operating instead of shutting down the entire string of LEDs. Bourns® LSP devices can be operated in the “on” state for the lifetime of the light fixture.

Bourns has been a leader in circuit protection for decades, and Bourns® LSP devices demonstrate the company’s commitment to providing cutting-edge circuit protection solutions for emerging applications. Bourns participates in standards committees and strives to provide a product that will allow designers to meet requirements such as those for Energy Star compliance. These products, as they pertain to LED lighting, must have a three year warranty and produce greater than 70 % of new light output for 35,000 hours or 25,000 hours for residential applications. With its commitment to excellence in technology and customer service, Bourns delivers solutions that meet or exceed these application requirements and many others. Bourns® LSP devices are designed to increase the lifetime of an LED application, minimizing the cost of repairs and replacement so that its inherent reliability can be fully realized.

ADDITIONAL RESOURCES

For more information on Bourns® LSP devices, including data sheets, samples, design kits, and Field Application Engineer support visit Bourns online at:

www.bourns.com

COPYRIGHT© 2011 • BOURNS, INC. • 7/11 e/TSP1118
“Bourns” and “TISP” are registered trademarks of Bourns, Inc. in the U.S. and other countries.