

NEW PRODUCT BRIEF



Bourns® Model CD0201-T2.0LC Bidirectional Ultra-low Capacitance ESD Protection TVS Diode

INTRODUCTION

The Bourns® Model CD0201-T2.0LC is a bidirectional ultra-low capacitance ESD protection TVS diode capable of handling IEC 61000-4-2 ±12 kV contact discharge and ±15 kV air discharge of ESD pulses. It is constructed in a tiny 0201 package (0.6 mm x 0.3 mm x 0.3 mm), minimizing PCB layout space and easing layout routing for impedance matching. Based on these design features, the Model CD0201-T2.0LC is suitable for ultra-high-speed interface protection including USB 3.0, USB 3.1, USB4®, Thunderbolt™, DisplayPort™, and 10 GbE.

The marketplace continues to seek ultra-low-capacitance, high-performance ESD protection in a compact 0201 package for high-speed communication interfaces. The Bourns® Model CD0201-T2.0LC meets designers' needs with its advanced deep snapback design – not only providing the desired ultra-low capacitance, but also enhanced ESD protection with high surge current handling capability.

CIRCUIT DIAGRAM

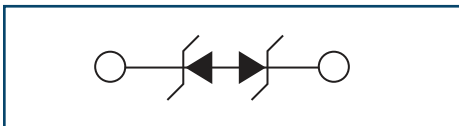

FEATURES AND BENEFITS

- Bidirectional ESD protection TVS diode
- Ultra-low capacitance: typical 0.18 pF
- High ESD protection @ IEC 61000-4-2:
 - ±12 kV contact discharge
 - ±15 kV air discharge
- 0201 footprint package
- RoHS compliant*
- Halogen free**

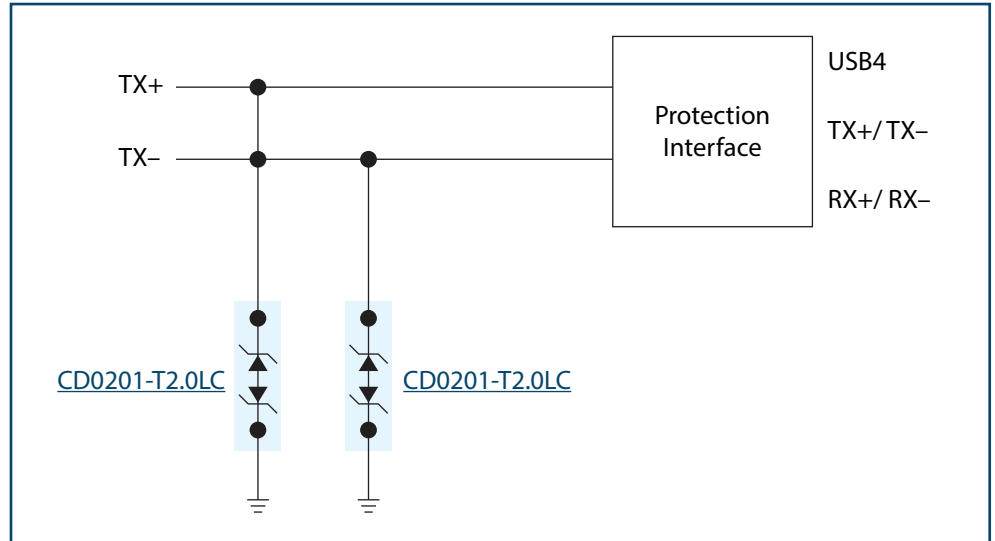

APPLICATIONS

Bourns® Model CD0201-T2.0LC offers enhanced protection performance with its ultra-low capacitance and high surge current capability in its compact 0201 footprint. These features meet the electrical and physical ESD protection requirements of ultra-high-speed data interface protocols including USB 3.0, USB 3.1, USB4®, Thunderbolt™, DisplayPort™, and 10GbE. It is important to note, however, that Model CD0201-T2.0LC is not recommended for use as DC supply line protection. In addition, this new Bourns® ESD protection TVS diode is capable of handling 7 A of surge current (8/20 μs), and provides superior clamping voltage performance as low as 4 V.

MARKET TRENDS

As advanced semiconductors continue to be susceptible to pulse surges, reliable ESD protection is essential for ultra-high-speed data communication interfaces. Designers of next-generation applications are also further challenged by the need for ever-smaller protection solutions in increasingly complex, space-constrained and densely populated PCB layouts.

HOW TO ORDER

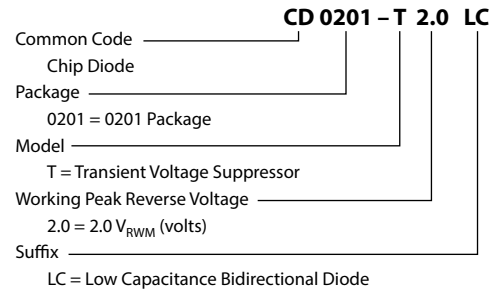

*RoHS Directive 2015/863, Mar 31, 2015 and Annex.
 **Bourns considers a product to be "halogen free" if (a) the Bromine (Br) content is 900 ppm or less; (b) the Chlorine (Cl) content is 900 ppm or less; and (c) the total Bromine (Br) and Chlorine (Cl) content is 1500 ppm or less.

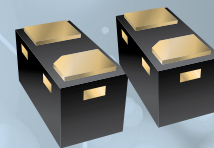

Bourns® Model CD0201-T2.0LC Bidirectional Ultra-low Capacitance ESD Protection TVS Diode

ELECTRICAL CHARACTERISTICS

Characteristic	Symbol	Test Conditions	Value	Unit
Reverse Standoff Voltage	V_{RWM}		2	V
Breakdown Voltage	V_{BR}	@ 1 mA	5.5 to 10	V
Clamping Voltage*	V_C	@ 7 A (8/20 μ s)	4	V
Leakage Current	I_R	@ 2 V	500 (max.)	nA
Capacitance	C_J	f = 1 MHz, $V_{RWM} = 2$ V	0.18 (typ.)	nF

*8/20 μ s current waveform per IEC 61000-4-5 measured at the peak surge current.

TYPICAL TLP MEASUREMENT

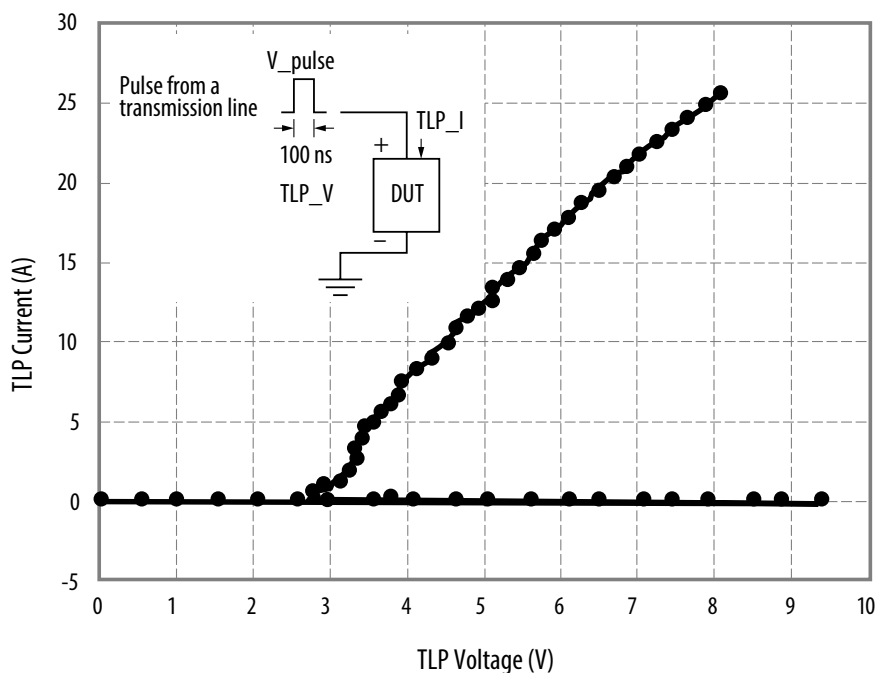

www.bourns.com

Americas: Tel +1-951 781-5500
Email americus@bourns.com

EMEA: Tel +36 88 885 877
Email eurocus@bourns.com

BOURNS®

Asia-Pacific: Tel +886-2 256 241 17
Email asiacus@bourns.com

COPYRIGHT© 2024 • BOURNS, INC. • 03/24 • e/ESD2272

"Bourns" is a registered trademark of Bourns, Inc. in the U.S. and other countries.

"USB4" is a registered trademark of USB Implementers Forum.

"Thunderbolt" is a trademark of Intel Corporation. "Displayport" is a trademark of VESA.