



Creating Efficient Solutions for Motor Drive-based Systems

CIRCUIT PROTECTION WHITE PAPER

BACKGROUND

More than half of all electrical energy produced is consumed by electric motors, and increasing the efficiency of these motors provides a tremendous opportunity for companies to reduce energy consumption significantly along with the potential to save billions of dollars. With regulations on the efficiency of motor systems becoming more stringent, the focus on motors is shifting from cost-effectiveness for basic functionality to cost-effectiveness for energy savings and regulation compliance. For a majority of the motors currently in use, it would be possible to realize energy savings by adding variable speed control features. An electronic controller can provide this capability by modulating the power being delivered to adjustable speed drives, variable speed drives, and variable frequency drives. Helping developers create efficient motor drive-based systems, Bourns offers a portfolio of ideally-suited components.

Important metrics for components going into efficient motor systems include power handling, which should be maximized, and power dissipation and temperature, which should be minimized. This paper will look at various types of motors, and discuss solutions from Bourns that primarily implement current sense resistors used in the motor control circuit.



Creating Efficient Solutions for Motor Drive-based Systems

MOTOR SYSTEM BASICS

Motors are used in a variety of capacities, including automotive seats and windows, building HVAC systems, power generation and utilities, consumer goods, medical equipment and devices, and industrial operations. Multiple legislative and regulatory entities have begun providing incentives to make motors more efficient wherever possible. Energy Star and Leadership in Energy and Environmental Design (LEED) are two of the domestic drivers.

In the U.S., the Motor and Generator Section of the National Electrical Manufacturers Association (NEMA) established the NEMA Premium program. All general purpose motors of at least 1 HP up to 200 HP were required to meet or exceed NEMA Premium motor efficiency levels beginning December 19, 2010. The program was established to assist purchasers in identifying higher efficiency motors which could save money and improve system reliability. NEMA premium motors optimize motor systems by reducing power consumption and the emissions associated with electrical power generation.

In Europe, the directive ErP 2009/125/EC defined the efficiency levels / classes, Eff1 and Eff2. In order to unify worldwide efficiency classifications, IEC 60034-30 (International Electric) defines four efficiency classes [IE1...IE4] for single-speed, 3-phase induction motors. There is a legislative timeline for motor efficiency transition based on these classes. IE1 – Efficiency class 1 – is standard efficiency and is comparable to the European Eff2 class. IE2 is high efficiency; it is higher efficiency than the European Eff2 class and identical to the U.S. levels of EPA Act. IE3 is premium efficiency, a new class in Europe, its higher efficiency than the Eff1 and almost identical to NEMA premium. IE4 is not yet defined. The result of adding efficiency to motor systems is typically improved performance, less power consumption, miniaturization, and integrated solutions which can provide process control and use manufacturing space more efficiently.



Creating Efficient Solutions for Motor Drive-based Systems

MOTOR SYSTEM BASICS (*Continued*)

A Typical Motor System

There are several coordinating units within a motor system. First, the motor itself operates at a specific voltage and converts electrical energy into mechanical energy. The motor receives electrical power from a motor drive, which is controlled by a motor/motion controller. Both the motor drive and motor can provide feedback to this controller. Even when integrated with the motor, the motor drive has a separate function. The motor drive provides the interface between the motor and its controller, producing power conversion, amplification, and sequencing of waveform signals. The motor drive must match the voltage level and power level of the controller and the signal type of the motor in order to drive it. One step further from the motor, the motor controller receives supply voltages and provides signals to the motor drive. The controller can have bidirectional interfaces with communication ports and user controls. Figure 1 shows the main units of the system and indicates the technology used in each.

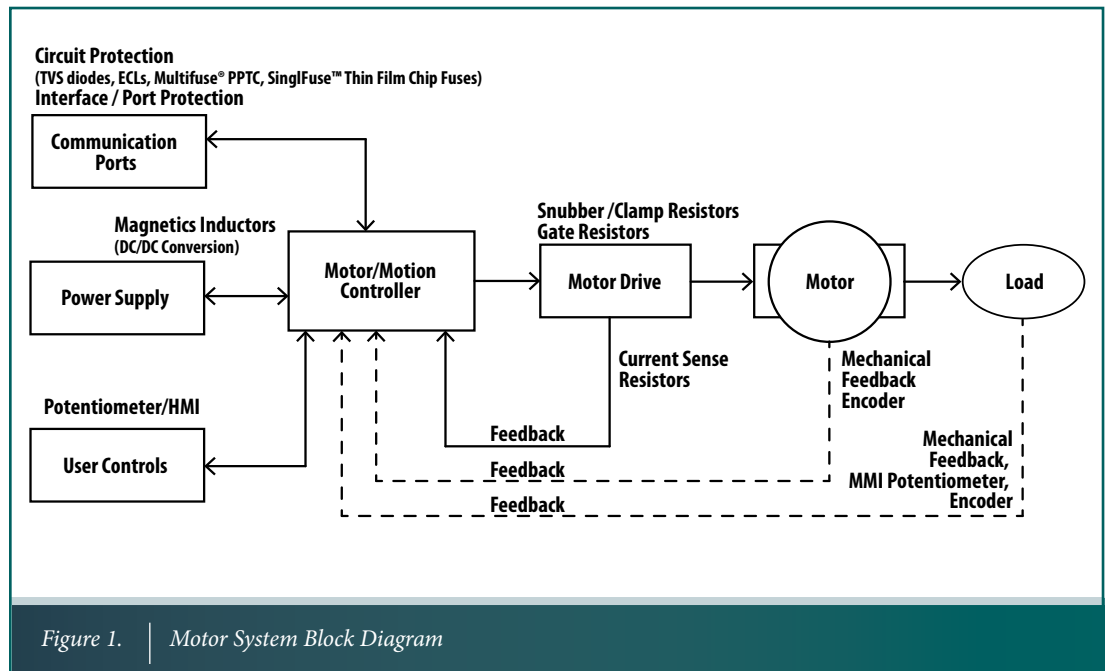



Creating Efficient Solutions for Motor Drive-based Systems

IMPROVING MOTOR EFFICIENCY

Two main motor types include AC induction, which is the focus of this paper, and direct current (DC) induction motor drives. The AC induction motor is one of the most popular motors used in consumer and industrial applications. Medium voltage motors range from 1 kV to over 11 kV. Compact AC drives are used in fans, pumps, and other applications below 25 kW. Standard AC drives are rated to 500 kW and are used in material handling and packaging applications. Premium AC drives cover the entire power range and are used in the most demanding applications. Though the AC induction motor is less efficient than other motor types, its virtues of low manufacturing cost and high reliability contribute to its popularity.

Variable frequency drives help improve the efficiency in AC motors. Adding a variable frequency drive to an induction motor design allows the speed of the electric motor to be adjusted by modulating the power that is delivered. The variable frequency drive can have an Active Front End (AFE), which is gaining relevance in the AC drive market. Active Front Ends convert the three-phase AC supply to DC power, using IGBT technology to control the level of DC current.

Advantages in addition to power savings include increased performance, reduced torque ripple, compensation for power fluctuations, power regeneration, power factor correction, and elimination of harmonics. With the rising cost of energy and emphasis on reducing reactive power, AFE technology is gaining relevance in the AC drive market.



Creating Efficient Solutions for Motor Drive-based Systems

IMPORTANCE OF CURRENT SENSING

Since the fundamental function of the motor drive is to serve as the interface between the motor and controller, it is essential that the drive accurately translates the input of the controller and provides feedback to the controller. Current sensing is the method commonly used for these tasks, effectively controlling the speed of the motor. Current sensing provides a voltage signal that corresponds to the current flowing at a particular point in the circuit. Current information is provided from the drive to the controller to detect any overcurrent or short circuit conditions that may arise. For circuits under 5.5 kW, a current sense resistor typically is sufficient for providing the current measurement. For medium power motor applications, power losses to discrete shunt resistors limit their efficiency. As an alternative to discrete resistors, IGBT modules are used. For current sensing, these IGBT modules have integrated shunt resistors which provide an accurate measurement and are cost-effective.

Current sense resistors are used at the power supply to motor driver interface and in the feedback loop in the drive section. From the motor to the control unit mechanical feedback can be provided using position feedback devices such as potentiometers and encoders.

Snubber resistors, also known as clamp resistors, and gate resistors are used at the motor driver interface. Snubber resistors are part of RC filters, which are used to remove any noise that might trigger the shutdown of the drive. The interfaces to the external portions of the motor system use different types of components focused on protection and manual adjustment. Circuit protection components such as Bourns® TVS diodes, Multifuse® PPTC resettable fuses, and metal oxide varistors (MOVs) provide port protection for communication interfaces that include Ethernet, RS-232, RS-485, CAN and others. Proposals for possible protection solutions for those communication interfaces can be found in Bourns® PortNote® Solutions (See Resources Section) .

Magnetics / power chokes are used at the power supply, and in motor control and DC/DC conversion (See Resources Section).

Trimmers also can be used in motor control. The user interface or HMI (Human Machine Interface) to the motor control unit may include potentiometers and other panel control components to provide manual adjustment, such as for speed and torque. The feedback from the load regarding the position of the motor may use position sensors such as single-turn or multturn precision potentiometers or encoders or a non-contacting Hall Effect sensor such as the Bourns® Model AMS22S.



Creating Efficient Solutions for Motor Drive-based Systems

SELECTING THE RIGHT CURRENT SENSE RESISTOR

The main selection criteria for current sense resistors includes a low resistance value to minimize power losses, low inductance because of high changes in current over time, tight tolerances on the initial resistance value, and a low Temperature Coefficient of Resistance (TCR) for accuracy. All materials experience a unique change in resistivity with temperature changes, so the TCR is an important factor in motors. A high temperature rating is also important for reliability, and a high peak power rating is equally important to ensure the resistor can handle high current pulses for short durations.

Bourns has a wide range of resistors that meet these criteria for use throughout the motor system. For example, the Bourns® Model CRA2512 Series, a metal strip SMD chip resistor, is rated to 3 watts of continuous applied power. It consists of a copper nickel alloy plate with solderable terminals and has the dimensions of a standard 2512 size resistor. Its high power density allows for some PCB space reduction. The TCR is specified as ± 75 PPM/ $^{\circ}\text{C}$ with the resistance being measured typically between an ambient temperature of 25°C and either $+125^{\circ}\text{C}$ or -55°C . Other options include the Bourns® Model CRF series and open air shunts such as Bourns® Models PWR4412 or PWR4413, used in IGBT inverters that use current sense resistors. Separately, Snubber Capacitor Modules (SCMs) consisting of diodes and capacitors are paired with external resistors to limit the IGBT switching overshoot, as shown in figure 2.

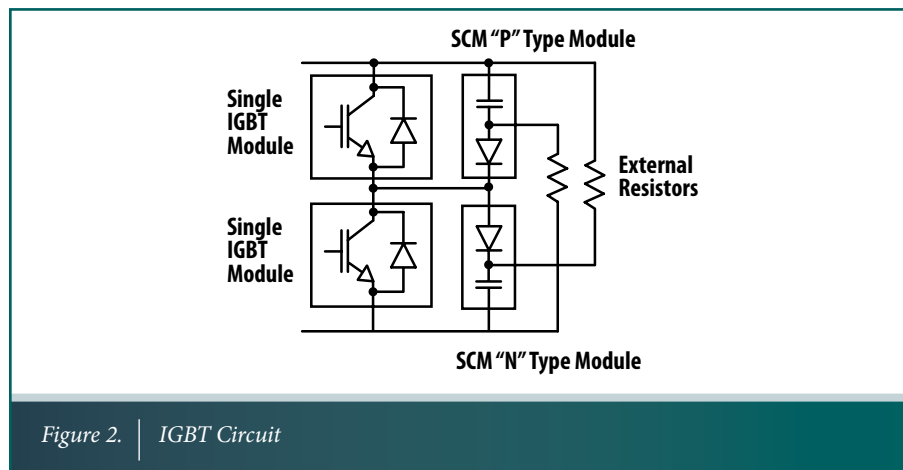

Figure 2. | IGBT Circuit

For the external resistors, thick film SMD resistors such as Bourns® Models CRM2512, CRM 2010, CRM1206, and CRM0805 have good surge capability and are available with power ratings up to 2 W. Thick film non-inductive resistors are available up to 35 W including Bourns® Models PWR163 and PWR263 in DPAK packages and Bourns® Models PWR220T and PWR221T in TO-220 packages.



Creating Efficient Solutions for Motor Drive-based Systems

WORKING WITH BOURNS

Bourns® components are available to meet the needs of designers and provide numerous benefits to motor system designs. Bourns® power resistors are compact and have high power handling capabilities. For example, the Bourns® Model PWR2010 is a small wirewound SMT resistor and is capable of handling large surges. Bourns® current sense resistors have a minimal surface temperature and can handle large loads. Bourns® Model CRA series offers a low TCR and a minimal surface temperature. These small chips have excellent power capability. Depending on the specification of the design, there is flexibility to choose multiple CRA chips in parallel or a single larger resistor with a higher power rating like Bourns® Model CRF Series. The layout of the board can contribute to the way the system performs, and Bourns Field Application Engineers (FAEs) can provide layout support to help meet the design specifications. Bourns performs surge tests and other application-specific tests, and additional specialized testing can be performed based on the needs of the customer.

The advantages of working with Bourns are illustrated in the case of a customer redesigning a 3-phase inverter/motor drive, specifically looking to replace the original through-hole current sense resistors with surface mount current sense resistors. A major concern in the design was the power handling capability of the resistors. It appeared that the only solution available would require two SMD resistors in parallel to replace each through-hole resistor. However, compact design and a minimal parts count were essential to this project. The customer was able to use a single Bourns® Model CRA2512 current sense resistor, which has higher power handling properties due to the Ni/Sn plating on the terminations. This plating method provides a more efficient transfer of heat from the resistor to the board. Using Bourns® Model CRA2512 current sense resistors, the customer was able to implement the design without increasing the number of components, achieve their cost and real estate objectives, and maintain reliability since the resistors were not susceptible to overheating. Figure 3 shows the solution.

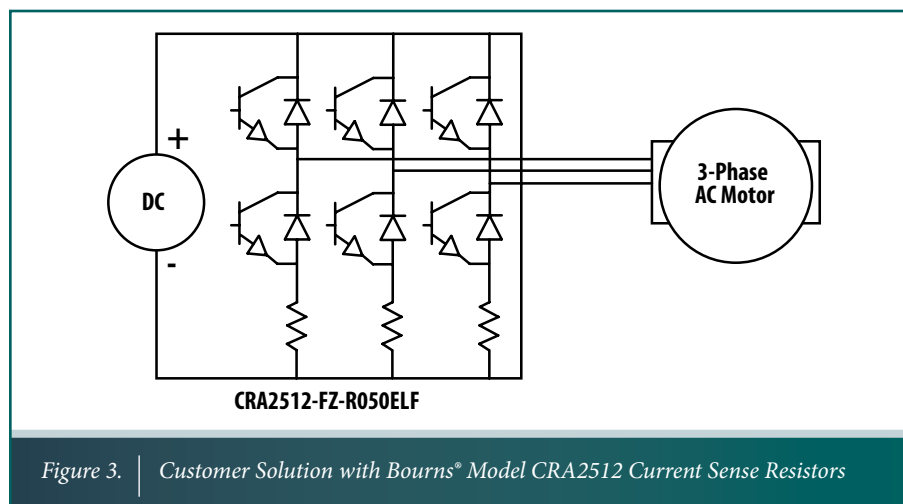

Figure 3. Customer Solution with Bourns® Model CRA2512 Current Sense Resistors



Creating Efficient Solutions for Motor Drive-based Systems

ACCESS TO DESIGN RESOURCES

With a rich and diverse portfolio of components, Bourns is an excellent choice as a supplier for motor system design. The company has been a leader in the circuit protection industry for decades. With its proven track record of designing parts that meet and exceed the current requirements of its customers, Bourns also continues to be aware of the changing needs of designers. This is reflected in the component selection Bourns offers. Bourns® current sense resistors are compact, have high power capability, and contribute to the overall efficiency of motor drives. FAEs can provide support to designers in creating a design that performs to specification. Design kits are available in order to gain familiarity with the performance of the parts before building a custom circuit board. Samples can be obtained from Bourns and through its distributors, and slight modifications are possible in order to meet the exact requirements of a given application. The flexibility, service, and quality of Bourns are great assets in partnering to create efficient motor designs.

RESOURCES

- <http://www.bourns.com/data/global/pdfs/CRA.pdf>
- <http://www.bourns.com/ProductFamily.aspx?name=magnetics>
- http://www.bourns.com/data/global/pdfs/Bourns_RS-485_AppNote.pdf
- <http://www.bourns.com/Library.aspx?name=PortNoteSolutions>

ADDITIONAL RESOURCES

For more information about Bourns' complete line of circuit protection solutions, please visit:

www.bourns.com

COPYRIGHT © 2012 • BOURNS, INC. • 2/12 • e/CPK1203

"PortNote" is a registered service mark of Bourns, Inc.

"Bourns", and "Multifuse" are registered trademarks of Bourns, Inc. in the U.S. and other countries.