 The Model TISP4SxxxBJ Series is obsolete and not recommended for new designs. The Model TISP4xxx-BJ Series is the recommended replacement product.

**TISP4SxxxL1BJ,  
TISP4SxxxM1BJ,  
TISP4SxxxM3BJ,  
TISP4SxxxT3BJ**

## BIDIRECTIONAL THYRISTOR OVERVOLTAGE PROTECTORS

### TISP4SxxxBJ Overvoltage Protector Series

#### TISP4SxxxBJ Overview

These protection devices are designed to limit overvoltages on the telephone line. Overvoltages are normally caused by a.c. power system or lightning flash disturbances which are induced or conducted onto the telephone line. A single device provides 2-point protection and is typically used for the protection of 2-wire telecommunication equipment (e.g., between the Ring and Tip wires for telephones and modems). Combinations of devices can be used for multi-point protection (e.g. 3-point protection between Ring, Tip and Ground).

The protector consists of a symmetrical voltage-triggered bidirectional thyristor. Overvoltages are initially clipped by breakdown clamping until the voltage rises to the breakover level, which causes the device to crowbar into a low-voltage on-state. This low-voltage on-state causes the current resulting from the overvoltage to be safely diverted within rated limits through the device. The high crowbar holding current helps prevent d.c. latchup as the diverted current subsides.

#### Summary Electrical Characteristics, $T_A = 25^\circ\text{C}$ (Unless Otherwise Noted)

Part Number	$V_{\text{DRM}}$ (V)	Max. $V_{\text{BO}}$ @ 100 V/ $\mu\text{s}$ (V)	Min. $I_{\text{H}}$ di/dt = 1 A/ms (mA)	Max. $I_{\text{BO}}$ (mA)	Max. $I_{\text{T}}$ (A)	Off-State Current $I_{\text{D}}$ @ $V_{\text{DRM}}$ ( $\mu\text{A}$ )	On-State Voltage $V_{\text{T}}$ @ $I_{\text{T}} = 2.2\text{ A}$ (V)	Typ. $C_{\text{j}}$ @ 1 V, 1 MHz (pF)
TISP4S040L1BJR-S	$\pm 25$	$\pm 40$	50	800	2.2	$\pm 5.0$	$\pm 5.0$	100
TISP4S040M1BJR-S	$\pm 25$	$\pm 40$	50	800	2.2	$\pm 5.0$	$\pm 5.0$	120
TISP4S077M3BJR-S	$\pm 58$	$\pm 77$	150	800	2.2	$\pm 5.0$	$\pm 5.0$	75
TISP4S088M3BJR-S	$\pm 65$	$\pm 88$	150	800	2.2	$\pm 5.0$	$\pm 5.0$	75
TISP4S098M3BJR-S	$\pm 75$	$\pm 98$	150	800	2.2	$\pm 5.0$	$\pm 5.0$	75
TISP4S160M3BJR-S	$\pm 120$	$\pm 160$	150	800	2.2	$\pm 5.0$	$\pm 5.0$	55
TISP4S180M3BJR-S	$\pm 140$	$\pm 180$	150	800	2.2	$\pm 5.0$	$\pm 5.0$	55
TISP4S240M3BJR-S	$\pm 180$	$\pm 240$	150	800	2.2	$\pm 5.0$	$\pm 5.0$	45
TISP4S260M3BJR-S	$\pm 190$	$\pm 260$	150	800	2.2	$\pm 5.0$	$\pm 5.0$	45
TISP4S300M3BJR-S	$\pm 220$	$\pm 300$	150	800	2.2	$\pm 5.0$	$\pm 5.0$	45
TISP4S350M3BJR-S	$\pm 275$	$\pm 350$	150	800	2.2	$\pm 5.0$	$\pm 5.0$	45
TISP4S350T3BJR-S	$\pm 275$	$\pm 350$	150	800	2.2	$\pm 5.0$	$\pm 5.0$	45
TISP4S400M3BJR-S	$\pm 300$	$\pm 400$	150	800	2.2	$\pm 5.0$	$\pm 5.0$	45

#### Device Symbol



Terminals T and R correspond to the alternative line designators of A and B

#### SMBJ Package (Top View)

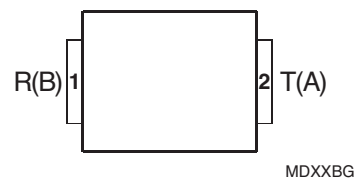

UL Pending

\*RoHS Directive 2002/95/EC Jan. 27, 2003 including annex and RoHS Recast 2011/65/EU June 8, 2011.

Specifications are subject to change without notice.

The device characteristics and parameters in this data sheet can and do vary in different applications and actual device performance may vary over time. Users should verify actual device performance in their specific applications.

# TISP4SxxxBJ Overvoltage Protector Series

**BOURNS®**

## How to Order

Device	Package	Carrier	Order As
TISP4SxxxzBJ	BJ (J-Bend DO-214AA/SMB)	Embossed Tape Reeled	TISP4SxxxzBJR-S

Insert xxx value corresponding to protection voltages.

## Absolute Maximum Ratings, $T_A = 25\text{ }^\circ\text{C}$ (Unless Otherwise Noted)

Parameter	Symbol	Value	Unit
Repetitive peak off-state voltage	$V_{DRM}$	TISP4S040L1BJR-S ± 25	V
		TISP4S040M1BJR-S ± 25	
		TISP4S077M3BJR-S ± 58	
		TISP4S088M3BJR-S ± 65	
		TISP4S098M3BJR-S ± 75	
		TISP4S160M3BJR-S ± 120	
		TISP4S180M3BJR-S ± 140	
		TISP4S240M3BJR-S ± 180	
		TISP4S260M3BJR-S ± 190	
		TISP4S300M3BJR-S ± 220	
		TISP4S350M3BJR-S ± 275	
		TISP4S350T3BJR-S ± 275	
		TISP4S400M3BJR-S ± 300	
Non-repetitive peak on-state pulse current 10/1000 $\mu\text{s}$ (GR-1089-CORE, 10/1000 $\mu\text{s}$ voltage wave shape)	$I_{TSP}$	TISP4SxxxLyBJR-S 30	A
TISP4SxxxMyBJR-S 50			
TISP4SxxxT3BJR-S 80			
Operating Temperature	$T_J$	-40 to +150	$^\circ\text{C}$
Storage Temperature	$T_{STG}$	-55 to +150	$^\circ\text{C}$

## Thermal Characteristics, $T_A = 25\text{ }^\circ\text{C}$ (Unless Otherwise Noted)

Parameter	Test Conditions	Min.	Nom.	Max.	Unit
$R\theta_{JA}$ Junction to free air thermal resistance	EIA/JESD51-3 PCB, $I_T = I_{TSM}(1000)$ , $T_A = 25\text{ }^\circ\text{C}$		115		$^\circ\text{C/W}$

JUNE 2012 - REVISED APRIL 2015

Specifications are subject to change without notice.

The device characteristics and parameters in this data sheet can and do vary in different applications and actual device performance may vary over time. Users should verify actual device performance in their specific applications.

## Parameter Measurement Information

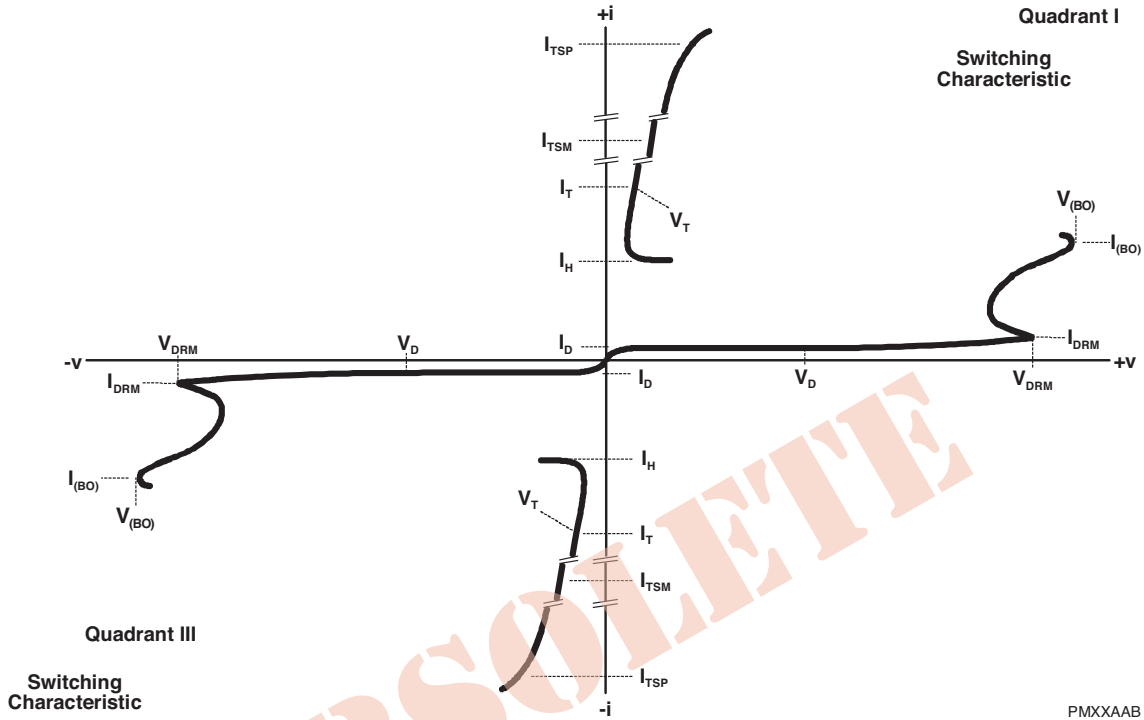
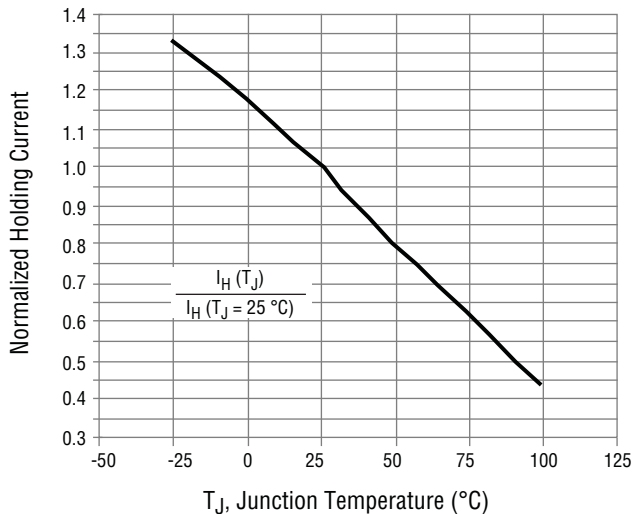

Figure 1. Voltage-current Characteristic for T and R Terminals  
All Measurements are Referenced to the R Terminal

## Typical Characteristics

NORMALIZED HOLDING CURRENT  
vs  
JUNCTION TEMPERATURE



NORMALIZED BREAKOVER VOLTAGE  
vs  
JUNCTION TEMPERATURE

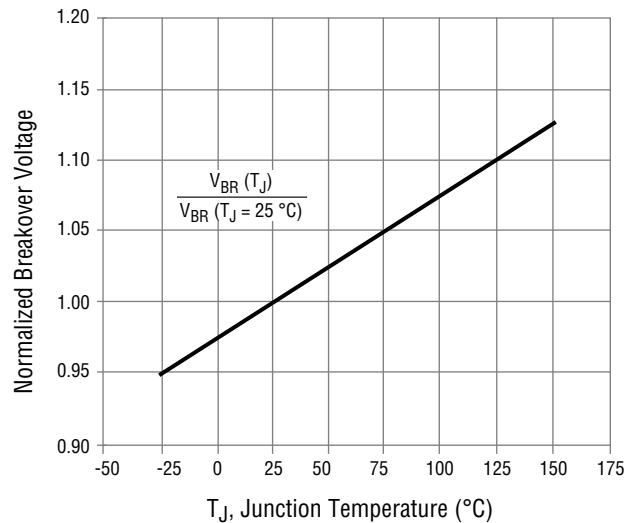

## Typical Characteristics

**NORMALIZED CAPACITANCE  
vs  
REVERSE VOLTAGE**

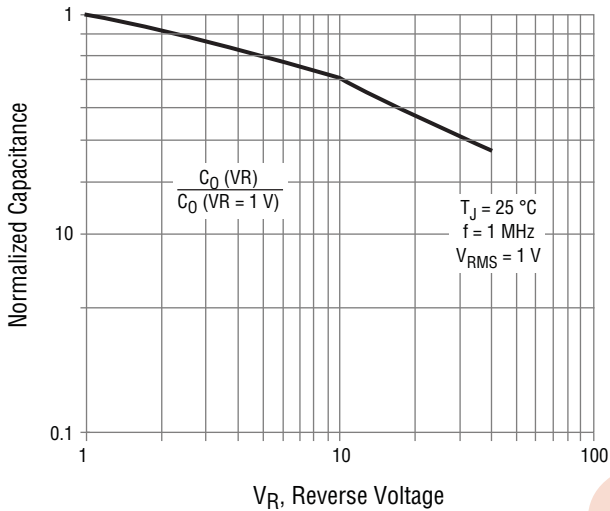

Excludes TISP4S040x1BJ devices as these are only rated up to 25 V.

**PEAK PULSE CURVE**

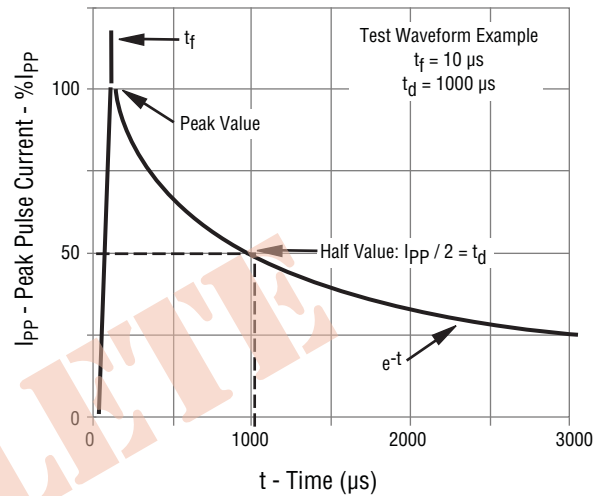

**OFF-STATE CURRENT  
vs  
JUNCTION TEMPERATURE**

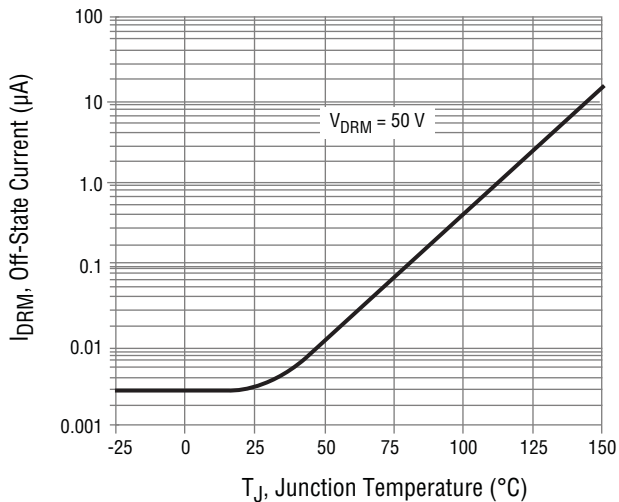

Excludes TISP4S040x1BJ devices as these devices cannot be operated at 50 V.

## Device Symbolization Code

Devices will be coded as below. As the device parameters are symmetrical, terminal 1 is not identified.

Device	Symbolization Code
TISP4S040L1BJR-S	KBL
TISP4S040M1BJR-S	GBL
TISP4S077M3BJR-S	GCL
TISP4S088M3BJR-S	GDL
TISP4S098M3BJR-S	GEL
TISP4S160M3BJR-S	GGL
TISP4S180M3BJR-S	GHL
TISP4S240M3BJR-S	GIL
TISP4S260M3BJR-S	GJL
TISP4S300M3BJR-S	GKL
TISP4S350M3BJR-S	GLL
TISP4S350T3BJR-S	GYL
TISP4S400M3BJR-S	GML

# TISP4SxxxBJ Overvoltage Protector Series

**BOURNS®**

## Typical Applications

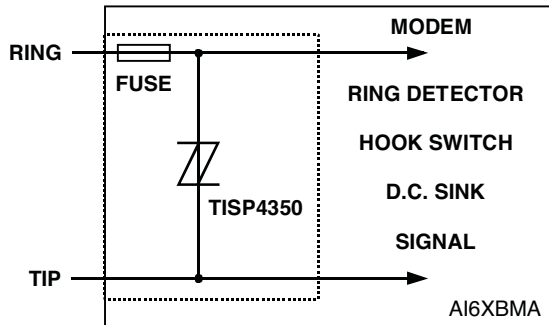

Modem Inter-wire Protection

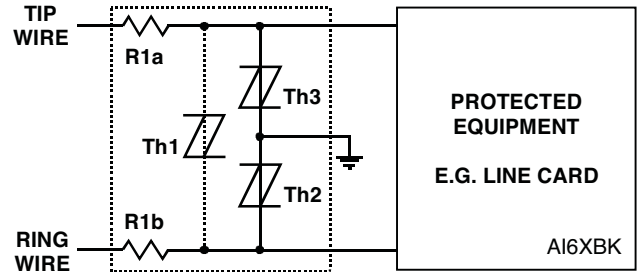

Protection Module

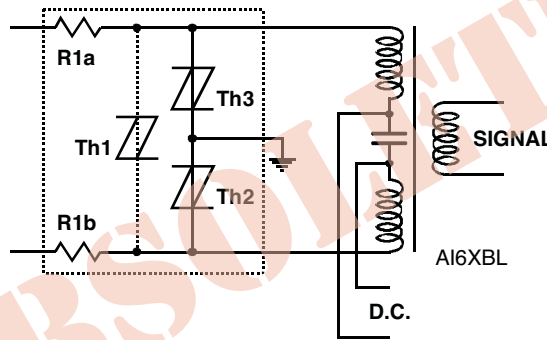

ISDN Protection

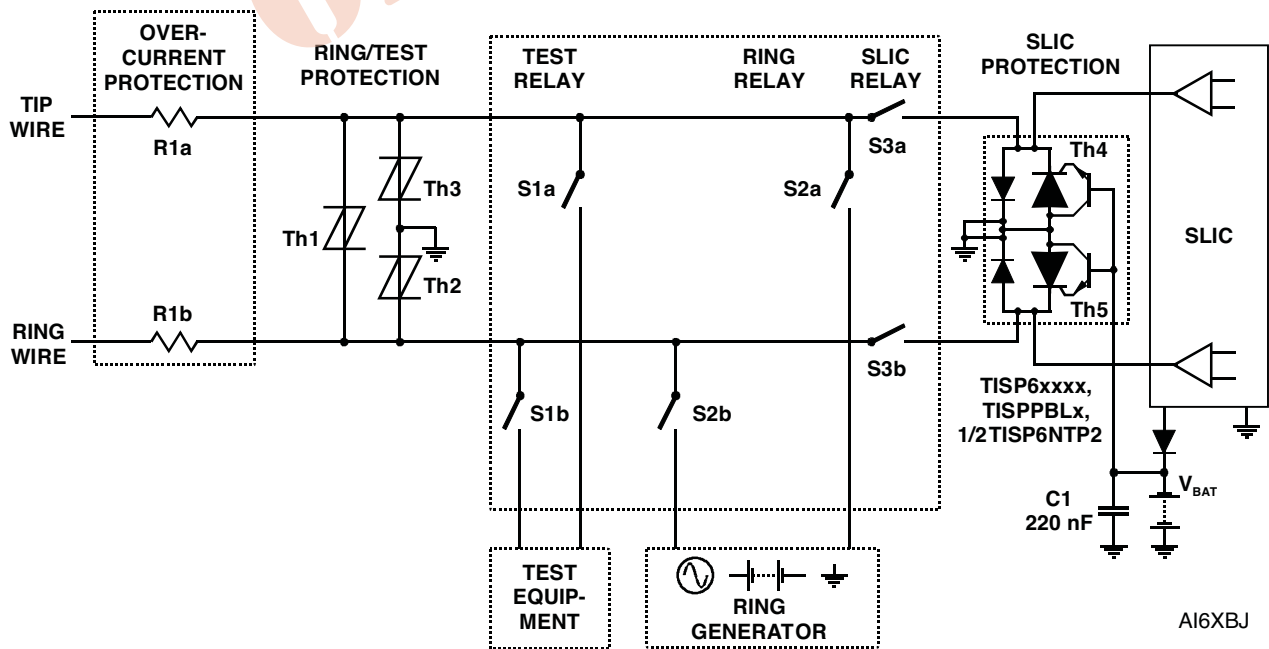

Line Card Ring/Test Protection

JUNE 2012 - REVISED APRIL 2015

Specifications are subject to change without notice.

The device characteristics and parameters in this data sheet can and do vary in different applications and actual device performance may vary over time.

Users should verify actual device performance in their specific applications.

## Package Outline Dimensions

This surface mount two terminal package consists of a circuit mounted on a lead frame and encapsulated within a plastic compound. The compound is designed to withstand normal soldering temperatures with no deformation and circuit performance characteristics will remain stable when operated in most high humidity conditions. Terminals require no additional cleaning or processing when used in soldered assembly.

### SMB (DO-214AA) Package

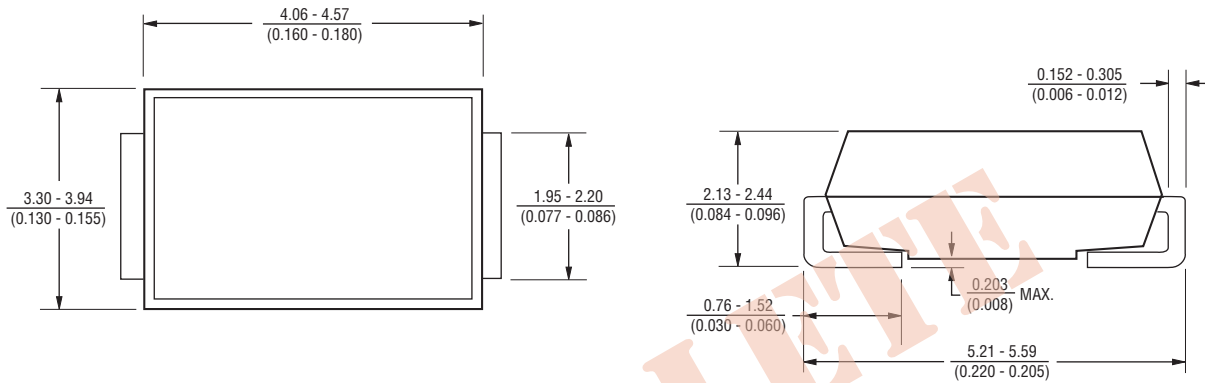

DIMENSIONS ARE : MILLIMETERS  
(INCHES)

## Recommended Printed Wiring Land Pattern Dimensions

### SMB (DO-214AA) Land Pattern

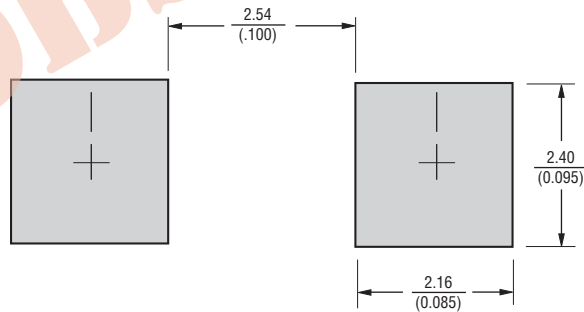

# TISP4SxxxBJ Overvoltage Protector Series

**BOURNS®**

## Tape & Reel Dimensions

The product will be dispensed in tape and reel format (see diagram below).

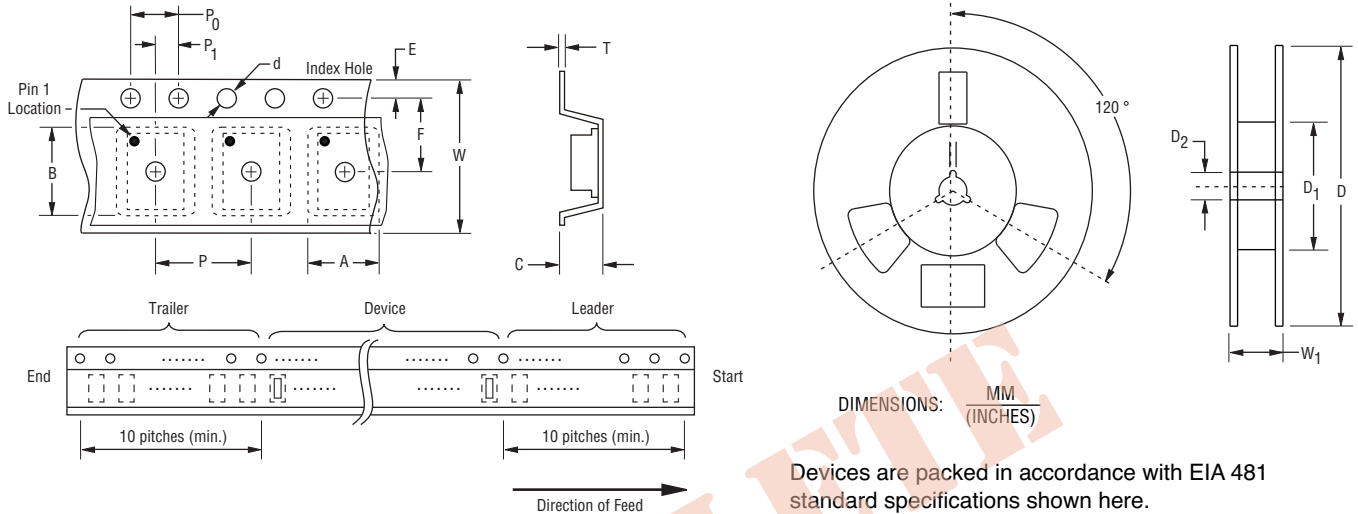

Item	Symbol	SMB (DO-214AA)
Carrier Width	A	$4.94 \pm 0.10$ (0.194 - 0.004)
Carrier Length	B	$5.57 \pm 0.10$ (0.210 ± 0.004)
Carrier Depth	C	$2.36 \pm 0.10$ (0.093 ± 0.004)
Sprocket Hole	d	$1.55 \pm 0.05$ (0.061 ± 0.002)
Reel Outside Diameter	D	$330$ (12.992)
Reel Inner Diameter	D <sub>1</sub>	$50.0$ (1.969) MIN.
Feed Hole Diameter	D <sub>2</sub>	$13.0 \pm 0.20$ (0.512 ± 0.008)
Sprocket Hole Position	E	$1.75 \pm 0.10$ (0.069 ± 0.004)
Punch Hole Position	F	$5.50 \pm 0.05$ (0.217 ± 0.002)
Punch Hole Pitch	P	$4.00 \pm 0.10$ (0.157 ± 0.004)
Sprocket Hole Pitch	P <sub>0</sub>	$4.00 \pm 0.10$ (0.157 ± 0.004)
Embossment Center	P <sub>1</sub>	$2.00 \pm 0.05$ (0.079 ± 0.002)
Overall Tape Thickness	T	$0.30 \pm 0.10$ (0.012 ± 0.004)
Tape Width	W	$12.00 \pm 0.20$ (0.472 ± 0.008)
Reel Width	W <sub>1</sub>	$18.4$ (0.724) MAX.
Quantity per Reel	--	3,000

**BOURNS®**

### Asia-Pacific:

Tel: +886-2 2562-4117

Fax: +886-2 2562-4116

### EMEA:

Tel: +36 88 520 390

Fax: +36 88 520 211

### The Americas:

Tel: +1-951 781-5500

Fax: +1-951 781-5700

[www.bourns.com](http://www.bourns.com)

"TISP" is a registered trademark of Bourns Ltd., a Bourns Company, in the United States and other countries, except that "TISP" is a registered trademark of Bourns, Inc. in China. "Bourns" is a registered trademark of Bourns, Inc. in the United States and other countries.

JUNE 2012 - REVISED APRIL 2015

Specifications are subject to change without notice.

The device characteristics and parameters in this data sheet can and do vary in different applications and actual device performance may vary over time.

Users should verify actual device performance in their specific applications.