



### Features

- Double contacts offer high reliability
- Low contact resistance
- Self-clean on contact area
- Splay terminals allow for automatic insertion by IC insertion machine
- Straight terminals are available for manual insertion



- RoHS compliant\*

## SND Series DIP Switch (Machine Insertable Type)

### Electrical Characteristics

Electrical Life .....2,000 operations min. per switch, 24 VDC, 25 mA  
 Non-Switching Rating .....100 mA, 50 VDC  
 Switching Rating .....25 mA, 24 VDC  
 Contact Resistance  
 .....50 milliohms max. at initial  
 .....100 milliohms max. after life test  
 Insulation Resistance.....100 megohms min.  
 Dielectric Strength .....500 VAC/minute  
 Capacitance .....5 pf max. between adjacent closed switch  
 Circuit .....Single pole single throw

### Environmental Characteristics

Mechanical Life..2,000 operations per switch  
 Operation Force .....1,000 g max.  
 Stroke .....1.0 mm  
 Operating Temp. Range....-20 °C to +85 °C  
 Storage Temperature .....-40 °C to +85 °C  
 Vibration Test .....MIL-STD-202F, Method 201A  
 Frequency .....10-55-10 Hz/minute  
 Directions .....X,Y,Z, three mutually perpendicular directions  
 Time .....2 hours each direction.  
 High reliability  
 Shock Test .....MIL-STD-202F, Method 213B, Condition A  
 Gravity .....50 G (peak value), 11 msec  
 Direction & Times.....6 sides and 3 times in each direction.  
 High reliability

### Physical Characteristics

Base and Cover Materials  
 .....UL94V-0 high-temperature thermoplastic PPS  
 Color .....Black  
 Actuator Materials .....UL94V-0 nylon thermoplastic  
 Color .....White  
 Contact Materials .....Alloy copper  
 Terminal Materials .....Brass  
 Contact Plating Materials  
 .....3 micro inches gold plating over 40 micro inches nickel  
 Terminal Plating Materials .....Gold  
 Wave Soldering Process†  
 ....Recommended solder temp. at 260 °C (500 °F) max., 5 sec.  
 Hand Soldering Process†  
 .....Use a soldering iron of 30 watts or less, controlled at 320 °C (608 °F) for approx. 2 sec. while applying solder  
 Standard Packaging  
 .....IC tubes/all poles in the "off" position

### Product Dimensions

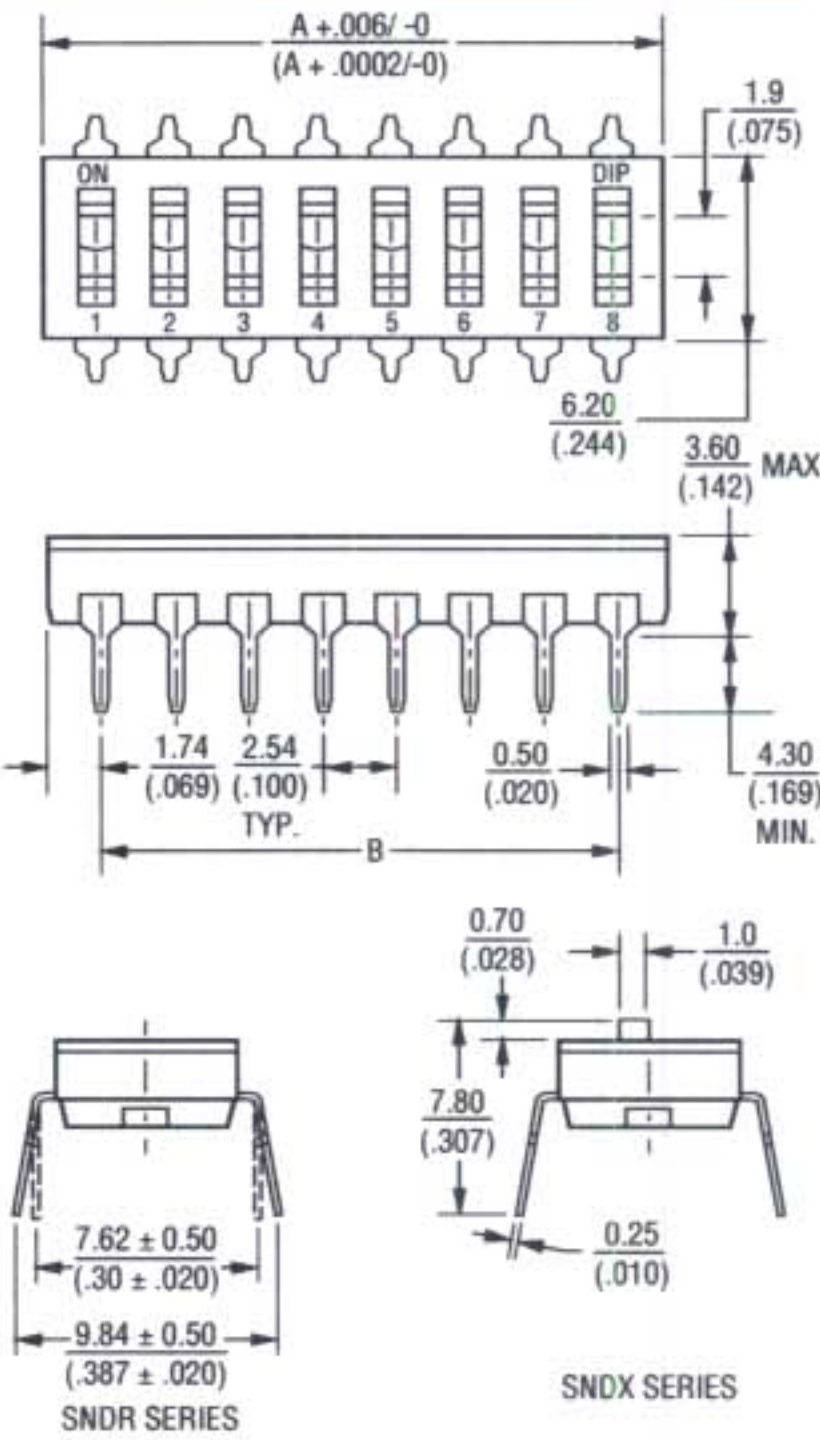

### RECOMMENDED PCB LAYOUT

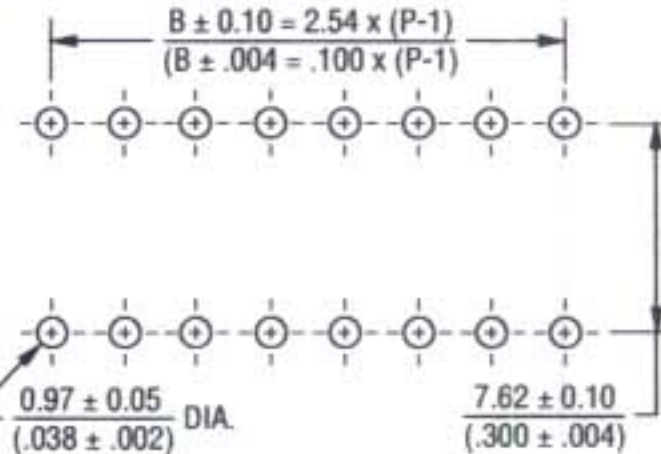

DIMENSIONS: MM (IN)

SCHEMATIC (TYP.)  
 1-12 POSITIONS AVAILABLE

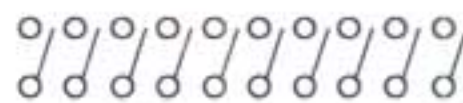

### SND Series Dimensions

MODEL NO.	POS.	DIM. A	DIM. B
SND-12	12	31.42 (1.237)	26.94 (1.100)
SND-10	10	26.34 (1.037)	22.86 (.900)
SND-9	9	23.80 (.937)	20.32 (.800)
SND-8	8	21.26 (.837)	17.78 (.700)
SND-7	7	18.72 (.737)	15.24 (.600)
SND-6	6	16.18 (.637)	12.70 (.500)
SND-5	5	13.64 (.537)	10.16 (.400)
SND-4	4	11.10 (.437)	7.62 (.300)
SND-3	3	8.56 (.337)	5.08 (.200)
SND-2	2	6.02 (.237)	2.54 (.100)
SND-1	1	3.48 (.137)	—

### How to Order

Model \_\_\_\_\_

Actuator \_\_\_\_\_  
 • X = Raised Actuator  
 • R = Recessed Actuator

Number of Positions \_\_\_\_\_  
 • 1 = 1 Position • 7 = 7 Positions  
 • 2 = 2 Positions • 8 = 8 Positions  
 • 3 = 3 Positions • 9 = 9 Positions  
 • 4 = 4 Positions • 10 = 10 Positions  
 • 5 = 5 Positions • 12 = 12 Positions  
 • 6 = 6 Positions

Terminal Type \_\_\_\_\_  
 • S = Splay (Machine Insertion Type)  
 • H = Straight (Manual Insertion Type)

Seal \_\_\_\_\_  
 • X = Standard (Not Sealed)  
 • T = Top Tape Sealed  
 ("R" actuator only, excluding 1 position)

### Reflow Soldering Profile

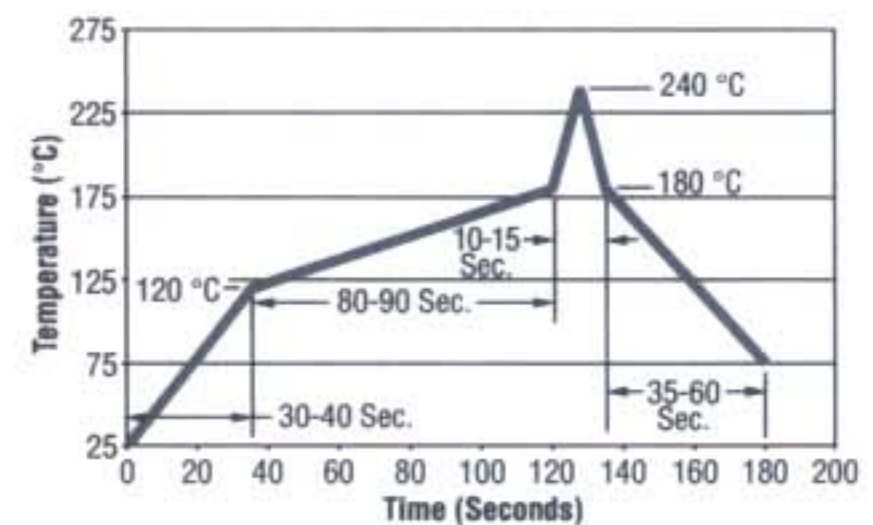

†For best results, keep all switch contacts in their "off" position for all operations.

\*RoHS Directive 2002/95/EC Jan 27 2003 including Annex. Specifications are subject to change without notice. Customers should verify actual device performance in their specific applications.

# SND Series DIP Switch (Machine Insertable Type)

**BOURNS®**

## Packaging Specifications

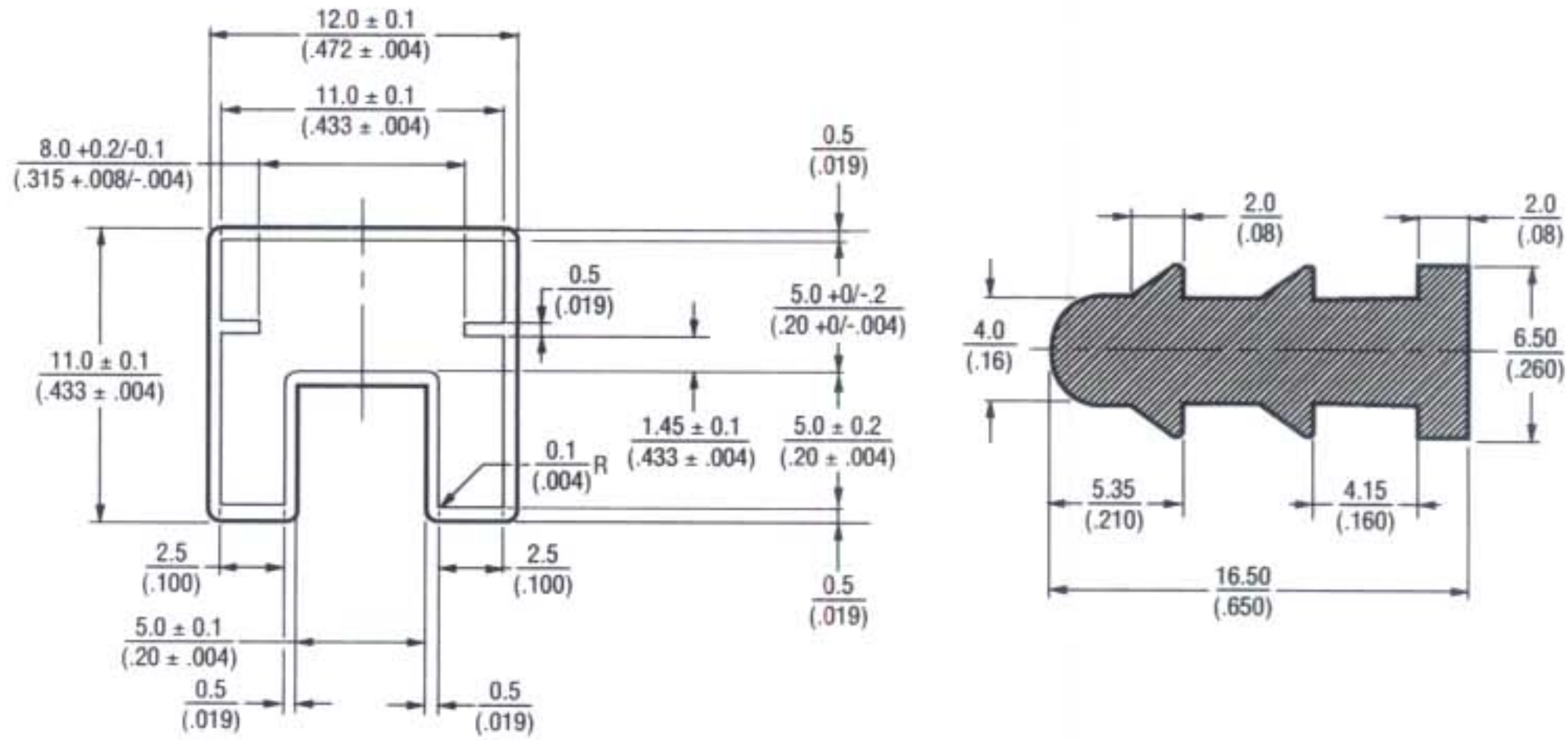

**OBSOLETE**

REV. 02/06

Specifications are subject to change without notice.  
Customers should verify actual device performance in their specific applications.