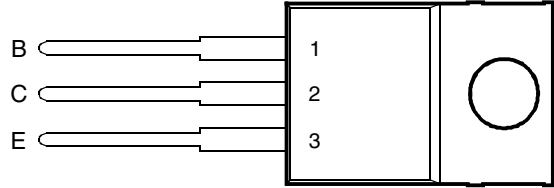




- 40 W at 25°C Case Temperature
- 2 A Continuous Collector Current
- 3 A Peak Collector Current
- Typical  $t_f = 200$  ns at 25°C

TO-220 PACKAGE  
(TOP VIEW)



This series is obsolete and not recommended for new designs.

Pin 2 is in electrical contact with the mounting base.

MDTRACA

**absolute maximum ratings at 25°C case temperature (unless otherwise noted)**

RATING	SYMBOL	VALUE	UNIT
Collector-base voltage ( $I_E = 0$ )	$V_{CB0}$	1000	V
Collector-emitter voltage ( $V_{BE} = 0$ )	$V_{CES}$	1000	V
Collector-emitter voltage ( $I_B = 0$ )	$V_{CEO}$	450	V
Continuous collector current	$I_C$	2	A
Peak collector current (see Note 1)	$I_{CM}$	3	A
Continuous device dissipation at (or below) 25°C case temperature	$P_{tot}$	40	W
Operating junction temperature range	$T_j$	-65 to +150	°C
Storage temperature range	$T_{stg}$	-65 to +150	°C

NOTE 1: This value applies for  $t_p \leq 2$  ms, duty cycle  $\leq 2\%$

OBSOLETE

**PRODUCT INFORMATION**

AUGUST 1978 - REVISED SEPTEMBER 2002  
Specifications are subject to change without notice.

**electrical characteristics at 25°C case temperature (unless otherwise noted)**

PARAMETER	TEST CONDITIONS	MIN	TYP	MAX	UNIT
$V_{CE(sus)}$ Collector-emitter sustaining voltage	$I_C = 0.1\text{ A}$ $L = 25\text{ mH}$ (see Note 2)	450			V
$I_{CES}$ Collector-emitter cut-off current	$V_{CE} = 1000\text{ V}$ $V_{BE} = 0$ $V_{CE} = 1000\text{ V}$ $V_{BE} = 0$ $T_C = 125^\circ\text{C}$			0.2 1	mA
$I_{EBO}$ Emitter cut-off current	$V_{EB} = 5\text{ V}$ $I_C = 0$			1	mA
$h_{FE}$ Forward current transfer ratio	$V_{CE} = 5\text{ V}$ $I_C = 0.1\text{ A}$ (see Notes 3 and 4)		35		
$V_{CE(sat)}$ Collector-emitter saturation voltage	$I_B = 0.03\text{ A}$ $I_C = 0.3\text{ A}$ $I_B = 0.2\text{ A}$ $I_C = 1\text{ A}$ (see Notes 3 and 4)			0.8 1	V
$V_{BE(sat)}$ Base-emitter saturation voltage	$I_B = 0.2\text{ A}$ $I_C = 1\text{ A}$ (see Notes 3 and 4)			1.1	V
$f_t$ Current gain bandwidth product	$V_{CE} = 10\text{ V}$ $I_C = 0.2\text{ A}$		12		MHz
$C_{ob}$ Output capacitance	$V_{CB} = 20\text{ V}$ $I_E = 0$ $f = 0.1\text{ MHz}$		60		pF

- NOTES: 2. Inductive loop switching measurement.  
 3. These parameters must be measured using pulse techniques,  $t_p = 300\ \mu\text{s}$ , duty cycle  $\leq 2\%$ .  
 4. These parameters must be measured using voltage-sensing contacts, separate from the current carrying contacts.  
 5. To obtain  $f_t$  the  $[h_{FE}]$  response is extrapolated at the rate of -6 dB per octave from  $f = 1\text{ MHz}$  to the frequency at which  $[h_{FE}] = 1$ .

**thermal characteristics**

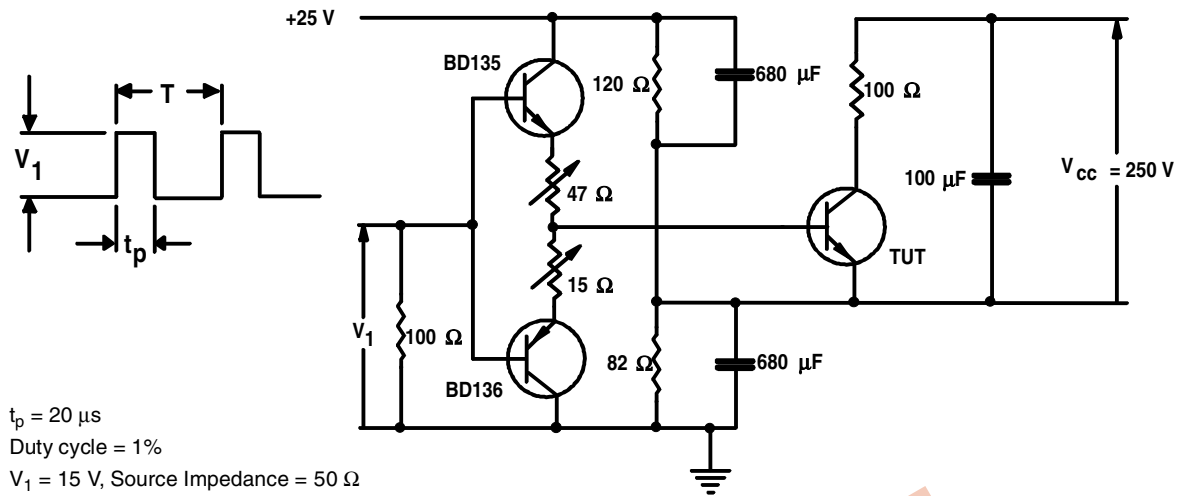
PARAMETER	MIN	TYP	MAX	UNIT
$R_{\theta JC}$ Junction to case thermal resistance			2.5	°C/W

**resistive-load-switching characteristics at 25°C case temperature (unless otherwise noted)**

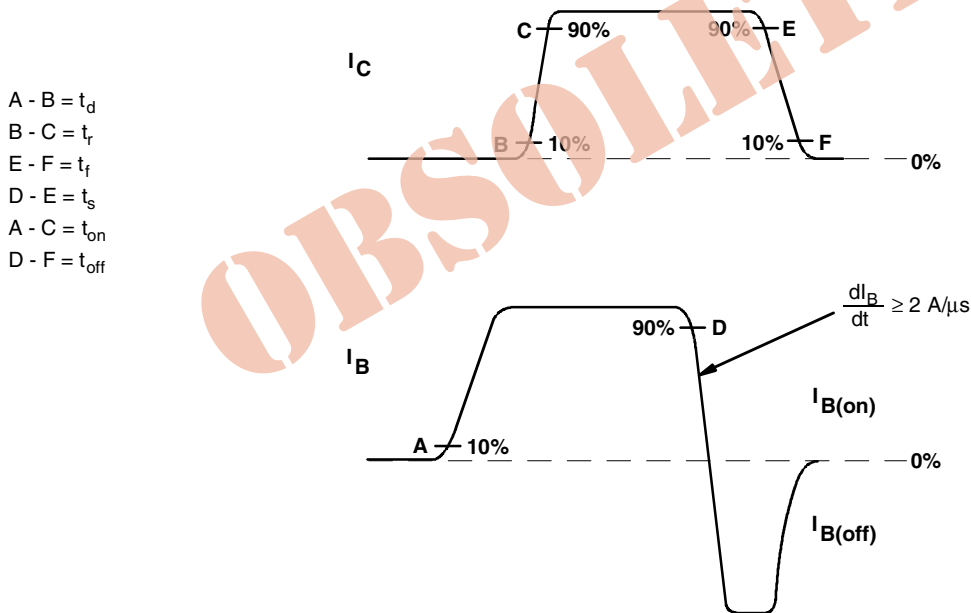
PARAMETER	TEST CONDITIONS †	MIN	TYP	MAX	UNIT
$t_{on}$ Turn on time	$I_C = 1\text{ A}$ $I_{B(on)} = 0.2\text{ A}$ $I_{B(off)} = -0.4\text{ A}$ $V_{CC} = 250\text{ V}$ (see Figures 1 and 2)		0.25	0.5	$\mu\text{s}$
$t_s$ Storage time			1.8		$\mu\text{s}$
$t_f$ Fall time			0.2		$\mu\text{s}$
$t_f$ Fall time	$I_C = 1\text{ A}$ $I_{B(on)} = 0.2\text{ A}$ $I_{B(off)} = -0.4\text{ A}$ $V_{CC} = 250\text{ V}$ $T_C = 95^\circ\text{C}$			0.4	$\mu\text{s}$

† Voltage and current values shown are nominal; exact values vary slightly with transistor parameters.

**PARAMETER MEASUREMENT INFORMATION**



**Figure 1. Resistive-Load Switching Test Circuit**

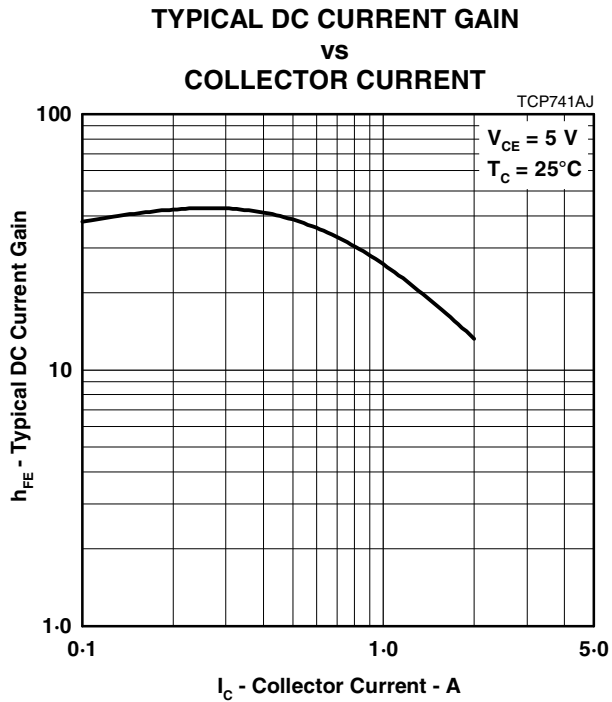


**Figure 2. Resistive-Load Switching Waveforms**

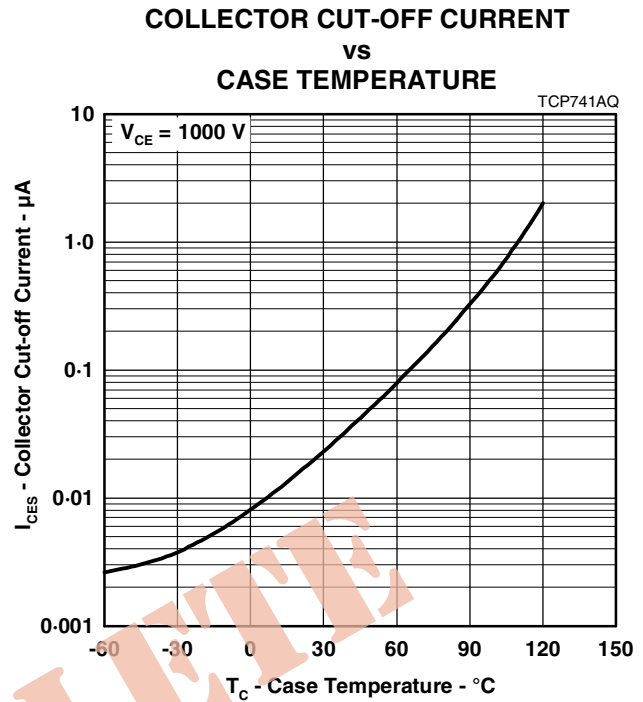
**PRODUCT INFORMATION**

AUGUST 1978 - REVISED SEPTEMBER 2002  
 Specifications are subject to change without notice.

**TYPICAL CHARACTERISTICS**

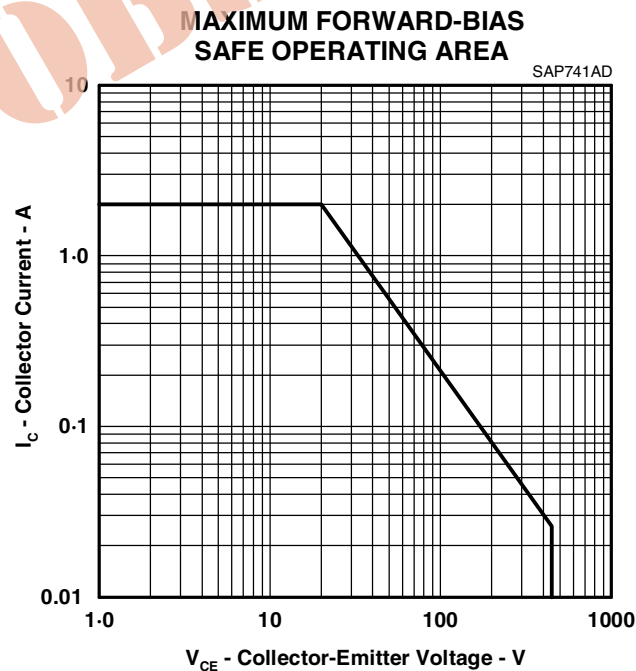


**Figure 3.**



**Figure 4.**

**MAXIMUM SAFE OPERATING REGIONS**



**Figure 5.**

**PRODUCT INFORMATION**

AUGUST 1978 - REVISED SEPTEMBER 2002  
 Specifications are subject to change without notice.

**THERMAL INFORMATION**

**THERMAL RESPONSE JUNCTION TO CASE  
VS  
POWER PULSE DURATION**

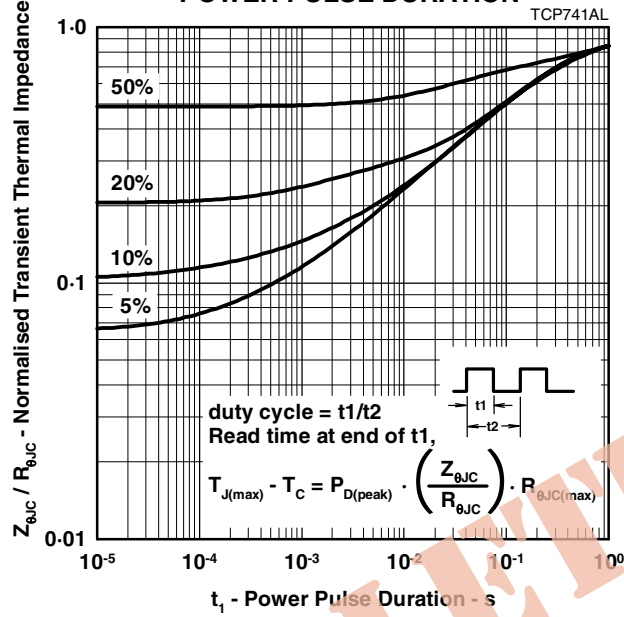


Figure 6.

**PRODUCT INFORMATION**

AUGUST 1978 - REVISED SEPTEMBER 2002  
Specifications are subject to change without notice.