



General Information

The Bourns® Model 1420A series is designed to protect DC power systems (such as the DC-side of photovoltaic systems) against the risk of the harmful effects of transient surges, up to rated limits. These surges can be the result of:

- Direct and indirect lightning strikes
- Power company load switching
- Upstream load switching at other facilities

This series is intended for the protection of sensitive electrical equipment of photovoltaic systems and other DC power systems like EV charging stations, AC-DC Inverters, and monitoring devices. It should be connected in parallel with the DC power system.



WARNING!

Only qualified personnel should install or service this system. Electrical safety precautions must be followed when installing or servicing this equipment. To prevent risk of electrical shock, turn off and lock out all power sources to the unit before making electrical connections or servicing.

For proper and safe operation, neutral and ground **MUST** be reliably connected. Failure to operate this unit from a solidly grounded power source of the proper configuration will reduce or impede operation, and may result in unit failure.

Installation

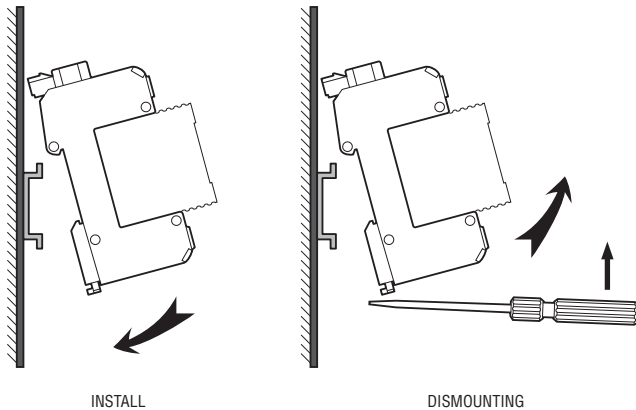
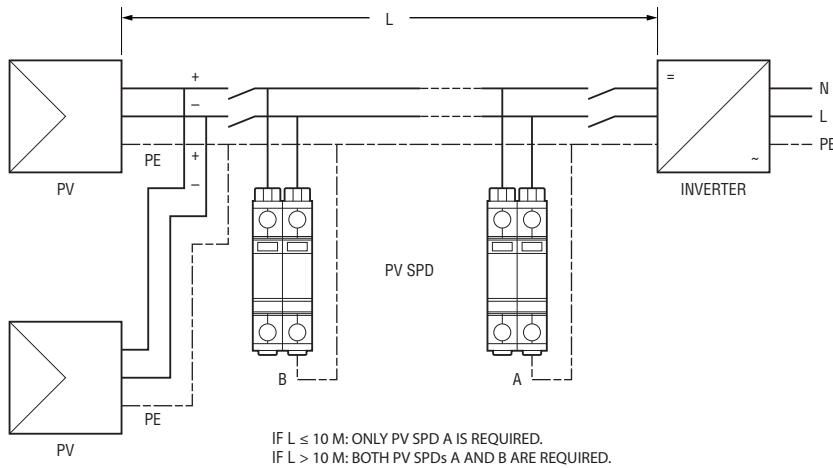

Fig.1: SPD mounting on DIN-Rail

1. When installing or replacing the SPD, it must be in a de-energized condition.
2. Install the DIN mounting rail (35 mm, re: EN 50022).
3. Snap-lock the SPD to the rail.
4. Connect wiring to the indicated terminals.
5. Ensure compliance with supplied instructions.
6. Apply power and observe correct operation of status indicators and, if utilized, remote alarm facilities.
7. Never Hi-Pot test any SPD. (This will cause premature failure or damage to the SPD.)

Wiring



Before making connections to the unit, verify that the unit model number and nameplate voltage rating are appropriate for connection to the intended power source.

For best performance, the unit should be positioned so that the length of the wiring to the Surge Protective Device (SPD) unit is minimized.

Wiring SPDs in PV system

A PV SPD should be installed as close as possible to the inverter. If the length of the wiring between this SPD and the PV generator (distance L, see Figures 2 & 3) is greater than 10 m, the PV generator requires a complementary SPD nearby, for protection (see Figures 2 & 3).

Fig.2: Positions of SPDs (V configuration) in the DC part as stipulated in Guide IEC 61643-32

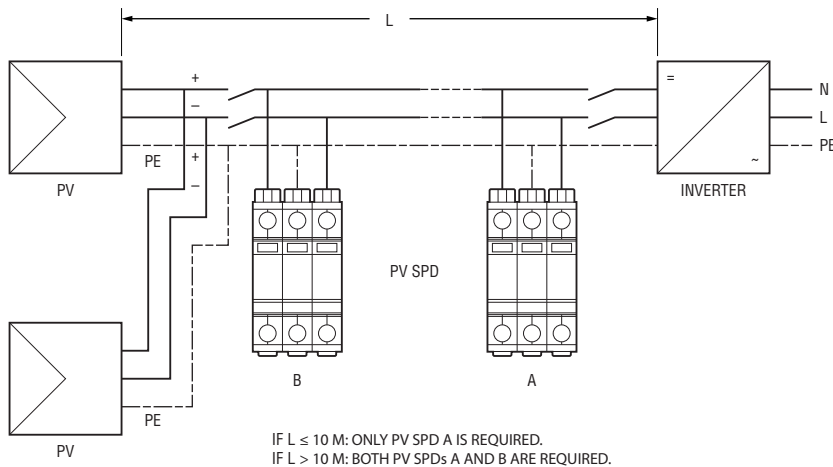

Fig.3: Positions of SPDs (Y configuration) in the DC part as stipulated in Guide IEC 61643-32

Wiring Connections

Conductor Type		
Min. Cross-section	+/- terminal: #12AWG (4 mm ²) PE terminal: #10AWG (6 mm ²)	
Max. Cross-section	#4AWG or 25 mm ² (stranded)	#2AWG or 35 mm ² (solid)
Insulation Stripped Back	0.4 in. or 10 mm	

Table 1: Connection wire size

Each SPD terminal is designed to accept wire sizes from #12AWG (4 mm²) to #2AWG (35 mm²) solid conductor or #4AWG (25 mm²) stranded conductor.

Insulation should be stripped back 10 mm before terminating into tunnel terminal.

Do not use excessive force when tightening the terminal; 2 ~ 2.5 Nm (18-22 lb-in) is recommended.

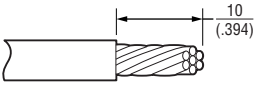
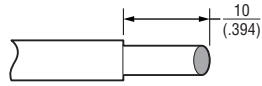

WARNING!

Select the proper Bourns® SPD unit according to your system voltage, configuration, and the anticipated surge environment.

Prior to installing the SPD, ensure that your facility's electric supply system is properly installed and connected in accordance with all applicable national and local codes and safety procedures.

Correct	Incorrect
	
	Insulation not cut back enough
	
	Insulation cut back too far

Fig. 4: Tightening the terminal

Specifications are subject to change without notice.

Users should verify actual device performance in their specific applications.

The products described herein and this document are subject to specific legal disclaimers as set forth on the last page of this document, and at www.bourns.com/docs/legal/disclaimer.pdf.

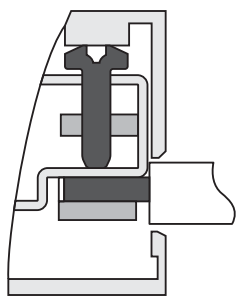
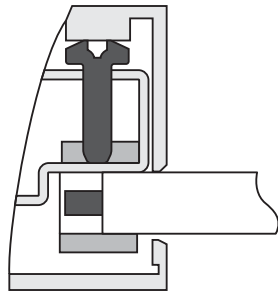
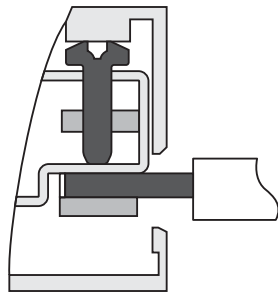
Status Indicator & Remote Signal

Remote Signal Contact	
	
Normal	Fault (Needs to be Replaced)

Table 2: Remote signal contact indication

A characteristic of all transient and surge protection devices is that they degrade in proportion to the magnitude and number of surge incidents to which they have been subjected. Status indication should be periodically monitored to determine if replacement is required. When the SPD indicator window turns **RED**, the remote signal contact closes between C (common) and NO (normally open). The pluggable module should be replaced as soon as possible.

Product Ratings & Limitations

Type 2CA SPD – Permanently connected SPDs for use on the load side of the main service disconnect, as described in the Standard for Safety, Surge Protective Devices (SPDs), UL-1449, Fourth Edition.

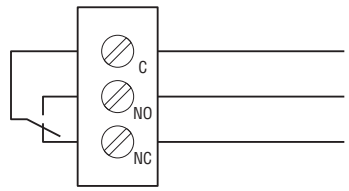
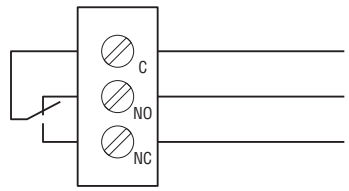
Voltage Protection Rating – To obtain the Voltage Protection Rating (VPR), in accordance with the Standard for Safety, Surge Protective Devices (SPDs), UL-1449, Fourth Edition, released 2014, as indicated on this product, the wire specified must be utilized to connect the SPD to your facility’s power grid. Connections made with unapproved conductors may result in different VPRs.

Circuit Ampacity Limitations – This product has been tested to withstand a voltage at or above the U_{pVDC} rating, and fault currents of up to 30 kA for 48 VDC network voltage products and 50 kA for network voltage products higher than 600 VDC without exposing live circuits or components on power sources, as described in the Standard for Safety, Surge Protective Devices (SPDs), UL-1449, Fourth Edition, released 2014.

Specifications are subject to change without notice.

Users should verify actual device performance in their specific applications.

The products described herein and this document are subject to specific legal disclaimers as set forth on the last page of this document, and at www.bourns.com/docs/legal/disclaimer.pdf.

Troubleshooting

If any of the diagnostic indicators reveal a problem, check all connections and voltages to the unit. If all connections are made and reliable, and proper voltages are supplied to the unit, please contact www.bourns.com.

NOTE

This guide is not comprehensive. It is assumed that the user will follow established safety precautions for working in an electrical environment. For more information on safety precautions and procedures, please consult the related organizations listed below.

- Underwriters Laboratories (UL)
- American National Standards Association (ANSI)
- Institute of Electrical and Electronics Engineers (IEEE).
- National Fire Protection Association (NFPA)
- National Electrical Mfgs. Association (NEMA)
- International Electrotechnical Commission (IEC)

Product Dimensions

Single Pole, "I" Configuration

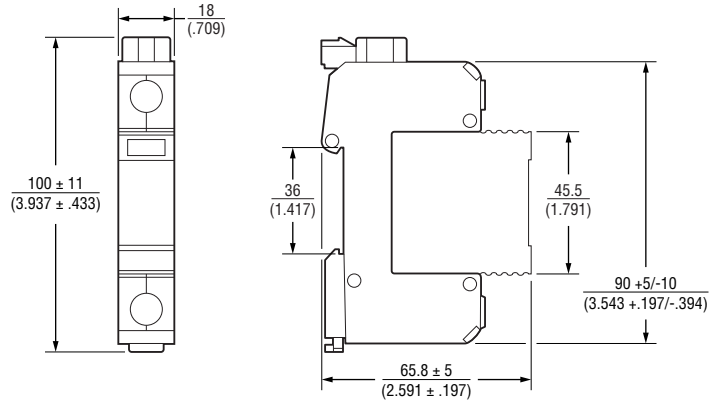

Two Poles, "V" Configuration

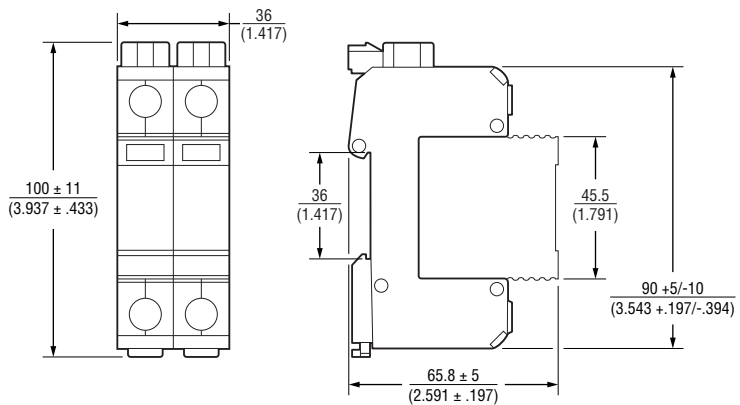

Three Poles, "Y" Configuration

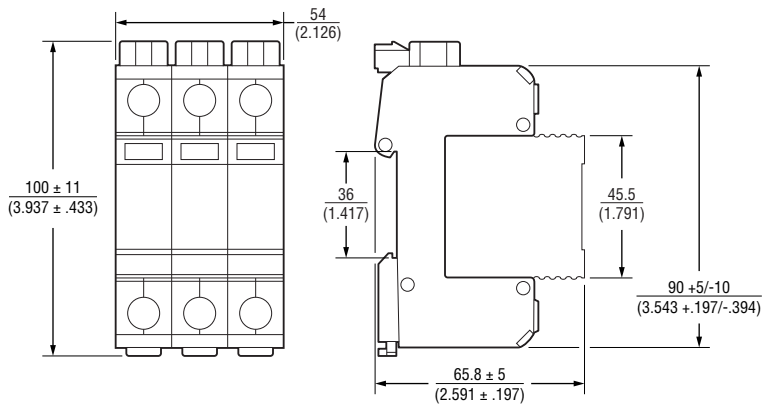

DIMENSIONS: $\frac{\text{MM}}{\text{(INCHES)}}$

This legal disclaimer applies to purchasers and users of Bourns® products manufactured by or on behalf of Bourns, Inc. and its affiliates (collectively, “Bourns”).

Unless otherwise expressly indicated in writing, Bourns® products and data sheets relating thereto are subject to change without notice. Users should check for and obtain the latest relevant information and verify that such information is current and complete before placing orders for Bourns® products.

The characteristics and parameters of a Bourns® product set forth in its data sheet are based on laboratory conditions, and statements regarding the suitability of products for certain types of applications are based on Bourns’ knowledge of typical requirements in generic applications. The characteristics and parameters of a Bourns® product in a user application may vary from the data sheet characteristics and parameters due to (i) the combination of the Bourns® product with other components in the user’s application, or (ii) the environment of the user application itself. The characteristics and parameters of a Bourns® product also can and do vary in different applications and actual performance may vary over time. Users should always verify the actual performance of the Bourns® product in their specific devices and applications, and make their own independent judgments regarding the amount of additional test margin to design into their device or application to compensate for differences between laboratory and real world conditions.

Unless Bourns has explicitly designated an individual Bourns® product as meeting the requirements of a particular industry standard (e.g., ISO/TS 16949) or a particular qualification (e.g., UL listed or recognized), Bourns is not responsible for any failure of an individual Bourns® product to meet the requirements of such industry standard or particular qualification. Users of Bourns® products are responsible for ensuring compliance with safety-related requirements and standards applicable to their devices or applications.

Bourns® products are not recommended, authorized or intended for use in nuclear, lifesaving, life-critical or life-sustaining applications, nor in any other applications where failure or malfunction may result in personal injury, death, or severe property or environmental damage. Unless expressly and specifically approved in writing by two authorized Bourns representatives on a case-by-case basis, use of any Bourns® products in such unauthorized applications might not be safe and thus is at the user’s sole risk. Life-critical applications include devices identified by the U.S. Food and Drug Administration as Class III devices and generally equivalent classifications outside of the United States.

Bourns expressly identifies those Bourns® standard products that are suitable for use in automotive applications on such products’ data sheets in the section entitled “Applications.” Unless expressly and specifically approved in writing by two authorized Bourns representatives on a case-by-case basis, use of any other Bourns® standard products in an automotive application might not be safe and thus is not recommended, authorized or intended and is at the user’s sole risk. If Bourns expressly identifies a sub-category of automotive application in the data sheet for its standard products (such as infotainment or lighting), such identification means that Bourns has reviewed its standard product and has determined that if such Bourns® standard product is considered for potential use in automotive applications, it should only be used in such sub-category of automotive applications. Any reference to Bourns® standard product in the data sheet as compliant with the AEC-Q standard or “automotive grade” does not by itself mean that Bourns has approved such product for use in an automotive application.

Bourns® standard products are not tested to comply with United States Federal Aviation Administration standards generally or any other generally equivalent governmental organization standard applicable to products designed or manufactured for use in aircraft or space applications. Bourns expressly identifies Bourns® standard products that are suitable for use in aircraft or space applications on such products’ data sheets in the section entitled “Applications.” Unless expressly and specifically approved in writing by two authorized Bourns representatives on a case-by-case basis, use of any other Bourns® standard product in an aircraft or space application might not be safe and thus is not recommended, authorized or intended and is at the user’s sole risk.

The use and level of testing applicable to Bourns® custom products shall be negotiated on a case-by-case basis by Bourns and the user for which such Bourns® custom products are specially designed. Absent a written agreement between Bourns and the user regarding the use and level of such testing, the above provisions applicable to Bourns® standard products shall also apply to such Bourns® custom products.

Users shall not sell, transfer, export or re-export any Bourns® products or technology for use in activities which involve the design, development, production, use or stockpiling of nuclear, chemical or biological weapons or missiles, nor shall they use Bourns® products or technology in any facility which engages in activities relating to such devices. The foregoing restrictions apply to all uses and applications that violate national or international prohibitions, including embargos or international regulations. Further, Bourns® products and Bourns technology and technical data may not under any circumstance be exported or re-exported to countries subject to international sanctions or embargoes. Bourns® products may not, without prior authorization from Bourns and/or the U.S. Government, be resold, transferred, or re-exported to any party not eligible to receive U.S. commodities, software, and technical data.

To the maximum extent permitted by applicable law, Bourns disclaims (i) any and all liability for special, punitive, consequential, incidental or indirect damages or lost revenues or lost profits, and (ii) any and all implied warranties, including implied warranties of fitness for particular purpose, non-infringement and merchantability.

For your convenience, copies of this Legal Disclaimer Notice with German, Spanish, Japanese, Traditional Chinese and Simplified Chinese bilingual versions are available at:

Web Page: <http://www.bourns.com/legal/disclaimers-terms-and-policies>

PDF: <http://www.bourns.com/docs/Legal/disclaimer.pdf>