



TISP61089D, TISP61089SD, TISP61089AD,  
TISP61089ASD

**DUAL FORWARD-CONDUCTING P-GATE THYRISTORS  
PROGRAMMABLE OVERVOLTAGE PROTECTORS**

**TISP61089 Gated Protector Series**

Overvoltage Protection for Negative Rail SLICs

Dual Voltage-Tracking Protectors

- '61089 for Battery Voltages to ..... -75 V
- '61089A for Battery Voltages to... -100 V
- Low Gate Triggering Current..... < 5 mA
- High Holding Current..... > 150 mA

Rated for GR-1089-CORE and K.44 Impulses

Impulse Wave Shape		I <sub>PPSM</sub> A
Voltage	Current	
2/10	2/10	120
10/700	5/310	40
10/1000	10/1000	30

2/10 Overshoot Voltage Specified

Element	I <sub>PP</sub> = 100 A, 2/10 V
Diode	8
SCR	12

Package Options

- Surface Mount 8-pin Small-Outline
- Line Feed-Thru Connection (D)
- Shunt Version Connection (SD)

**Additional Information**

Click these links for more information:



[PRODUCT SELECTOR](#) [TECHNICAL LIBRARY](#) [INVENTORY](#) [SAMPLES](#) [CONTACT](#)

**Agency Recognition**

Description	
UL	File Number: <a href="#">E215609</a>

..... UL Recognized Component

**D Package Top View and Device Symbol for Feed-Thru Pin-Out**

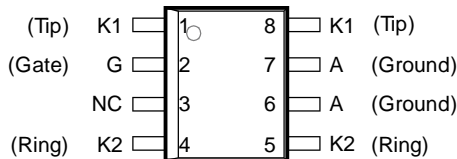

NC - No internal connection  
Terminal typical application names shown in parenthesis

MD6XBDa

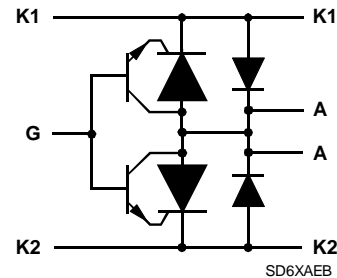

SD6XAEB

**D Package Top View and Device Symbol for Shunt (SD) Pin-Out**

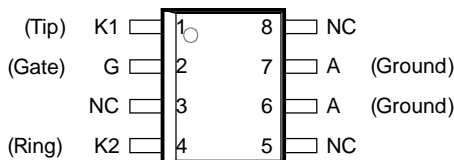

NC - No internal connection  
Terminal typical application names shown in parenthesis

MD6XBE

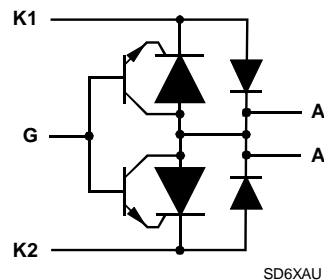

SD6XAU



**WARNING Cancer and Reproductive Harm**  
[www.P65Warnings.ca.gov](http://www.P65Warnings.ca.gov)

NOVEMBER 1995 – REVISED JULY 2019

\*RoHS Directive 2015/863, Mar 31, 2015 and Annex.

Specifications are subject to change without notice.

Users should verify actual device performance in their specific applications.

The products described herein and this document are subject to specific legal disclaimers as set forth on the last page of this document, and at [www.bourns.com/docs/legal/disclaimer.pdf](http://www.bourns.com/docs/legal/disclaimer.pdf).

# TISP61089 Gated Protector Series

**BOURNS®**

## How to Order

Device	Package	Carrier	Order As	Device	Package	Carrier	Order As
TISP61089	D (Small-Outline)	R†	TISP61089DR-S	TISP61089A	D (Small-Outline)	R†	TISP61089ADR-S
TISP61089S	D (Small-Outline)	R†	TISP61089SDR-S	TISP61089AS	D (Small-Outline)	R†	TISP61089ASDR-S
† Carrier R is Embossed Tape Reeled				† Carrier R is Embossed Tape Reeled			

## Description

These '61089 parts are all dual forward-conducting buffered p-gate thyristor (SCR) overvoltage protectors. They are designed to protect monolithic SLICs (Subscriber Line Interface Circuits) against overvoltages on the telephone line caused by lightning, a.c. power contact and induction. The '61089 limits voltages that exceed the SLIC supply rail voltage. The '61089 parameters are specified to allow equipment compliance with Telcordia (formerly Bellcore) GR-1089-CORE and ITU-T recommendations K.20, K.21 and K.45.

The SLIC line driver section is typically powered from 0 V (ground) and a negative (battery) voltage. The protector gate is connected to this negative supply. This references the protection (clipping) voltage to the negative supply voltage. The protection voltage will then track the negative supply voltage and the overvoltage stress on the SLIC is minimized.

Positive overvoltages are clipped to ground by diode forward conduction. Negative overvoltages are initially clipped close to the SLIC negative supply rail value. If sufficient current is available from the overvoltage, then the protector SCR will switch into a low voltage on-state condition. As the overvoltage subsides the high holding current of '61089 SCR helps prevent d.c. latchup.

The '61089 is intended to be used with a series resistance of at least 25  $\Omega$  and a suitable overcurrent function for Telcordia compliance. Power fault conditions require a series overcurrent element which either interrupts or reduces the circuit current before the '61089 current rating is exceeded. For equipment compliant to ITU-T recommendations K.20 or K.21 or K.45 only, the series resistor value is set by the coordination requirements. For coordination with a 400 V limit GDT, a minimum series resistor value of 10  $\Omega$  is recommended.

The '61089 buffered gate design reduces the loading on the SLIC supply during overvoltages caused by power cross and induction. The regular pin-out for surface mount and through-hole packages is a feed through configuration. Connection to the SLIC is made via the '61089, Ring through pins 4 - 5 and Tip through pins 1 - 8. A non-feed-through surface mount (D) package is available. This shunt (SD) version pin-out does not make duplicate connections to pin 5 and pin 8 which increases package creepage distance from ground of the other connections from about 0.7 mm to over 3 mm. High voltage ringing SLICs, with battery voltages below -100 V and down to -155 V, can be protected by the TISP61089B device. Details of this device are in the TISP61089B data sheet.

NOVEMBER 1995 – REVISED JULY 2019

Specifications are subject to change without notice.

Users should verify actual device performance in their specific applications.

The products described herein and this document are subject to specific legal disclaimers as set forth on the last page of this document, and at [www.bourns.com/docs/legal/disclaimer.pdf](http://www.bourns.com/docs/legal/disclaimer.pdf).

## Absolute Maximum Ratings, $-40\text{ °C} \leq T_J \leq 85\text{ °C}$ (Unless Otherwise Noted)

Rating	Symbol	Value	Unit
Repetitive peak off-state voltage, $V_{GK} = 0$	61089	-100	V
	'61089A	-120	
Repetitive peak gate-cathode voltage, $V_{KA} = 0$	61089	-85	V
	'61089A	-120	
Non-repetitive peak on-state pulse current (see Notes 1 and 2) 10/1000 $\mu\text{s}$ (Telcordia (Bellcore) GR-1089-CORE, Issue 2, February 1999, Section 4) 5/320 $\mu\text{s}$ (ITU-T K.20, K.21 & K.45, K.44 open-circuit voltage wave shape 10/700 $\mu\text{s}$ ) 1.2/50 $\mu\text{s}$ (Telcordia (Bellcore) GR-1089-CORE, Issue 2, February 1999, Section 4) 2/10 $\mu\text{s}$ (Telcordia (Bellcore) GR-1089-CORE, Issue 2, February 1999, Section 4)	$I_{PPSM}$	30	A
		40	
		100	
		120	
Non-repetitive peak on-state current, $V_{GG} = -75\text{ V}$ , 50 Hz to 60 Hz (see Notes 1 and 2) 0.1 s 1 s 5 s 300 s 900 s	$I_{TSM}$	11	A
		4.8	
		2.7	
		0.95	
		0.93	
Non-repetitive peak gate current, 1/2 $\mu\text{s}$ pulse, cathodes commoned (see Notes 1 and 2)	$I_{GSM}$	+40	A
Operating free-air temperature range	$T_A$	-40 to +85	$^{\circ}\text{C}$
Junction temperature	$T_J$	-40 to +150	$^{\circ}\text{C}$
Storage temperature range	$T_{stg}$	-40 to +150	$^{\circ}\text{C}$

- NOTES: 1. Initially the protector must be in thermal equilibrium with  $-40\text{ °C} \leq T_J \leq 85\text{ °C}$ . The surge may be repeated after the device returns to its initial conditions. Gate voltage ranges are -20 V to -75 V for the '61089 and -20 V to -100 V for the '61089A.
2. The rated current values may be applied either to the Ring to Ground or to the Tip to Ground terminal pairs. Additionally, both terminal pairs may have their rated current values applied simultaneously (in this case the Ground terminal current will be twice the rated current value of an individual terminal pair). Above 85  $^{\circ}\text{C}$ , derate linearly to zero at 150  $^{\circ}\text{C}$  lead temperature.

## Recommended Operating Conditions

Component		Min	Typ	Max	Unit
$C_G$	Gate decoupling capacitor	100	220		nF
$R_S$	Series resistor for GR-1089-CORE first-level surge survival	25			$\Omega$
	Series resistor for GR-1089-CORE first-level and second-level surge survival	40			$\Omega$
	Series resistor for GR-1089-CORE intra-building port surge survival	8			$\Omega$
	Series resistor for K.20, K.21 and K.45 coordination with a 400 V primary protector	10			$\Omega$

Electrical Characteristics,  $T_J = 25\text{ }^\circ\text{C}$  (Unless Otherwise Noted)

Parameter	Test Conditions	Min	Typ	Max	Unit
$I_D$ Off-state current	$V_D = V_{DRM}, V_{GK} = 0$	$T_J = 25\text{ }^\circ\text{C}$		-5	$\mu\text{A}$
		$T_J = 85\text{ }^\circ\text{C}$		-50	$\mu\text{A}$
$V_{(BO)}$ Breakover voltage	2/10 $\mu\text{s}$ , $I_{PP} = -56\text{ A}$ , $R_S = 45\ \Omega$ , $V_{GG} = -48\text{ V}$ , $C_G = 220\text{ nF}$		-57		V
	2/10 $\mu\text{s}$ , $I_{PP} = -100\text{ A}$ , $R_S = 50\ \Omega$ , $V_{GG} = -48\text{ V}$ , $C_G = 220\text{ nF}$		-60		
	1.2/50 $\mu\text{s}$ , $I_{PP} = -53\text{ A}$ , $R_S = 47\ \Omega$ , $V_{GG} = -48\text{ V}$ , $C_G = 220\text{ nF}$		-60		
	1.2/50 $\mu\text{s}$ , $I_{PP} = -96\text{ A}$ , $R_S = 52\ \Omega$ , $V_{GG} = -48\text{ V}$ , $C_G = 220\text{ nF}$		-64		
$V_{GK(BO)}$ Gate-cathode impulse breakover voltage	2/10 $\mu\text{s}$ , $I_{PP} = -56\text{ A}$ , $R_S = 45\ \Omega$ , $V_{GG} = -48\text{ V}$ , $C_G = 220\text{ nF}$		9		V
	2/10 $\mu\text{s}$ , $I_{PP} = -100\text{ A}$ , $R_S = 50\ \Omega$ , $V_{GG} = -48\text{ V}$ , $C_G = 220\text{ nF}$		12		
	1.2/50 $\mu\text{s}$ , $I_{PP} = -53\text{ A}$ , $R_S = 47\ \Omega$ , $V_{GG} = -48\text{ V}$ , $C_G = 220\text{ nF}$		12		
	1.2/50 $\mu\text{s}$ , $I_{PP} = -96\text{ A}$ , $R_S = 52\ \Omega$ , $V_{GG} = -48\text{ V}$ , $C_G = 220\text{ nF}$		16		
$V_F$ Forward voltage	$I_F = 5\text{ A}$ , $t_w = 200\ \mu\text{s}$			3	V
$V_{FRM}$ Peak forward recovery voltage	2/10 $\mu\text{s}$ , $I_{PP} = 56\text{ A}$ , $R_S = 45\ \Omega$ , $V_{GG} = -48\text{ V}$ , $C_G = 220\text{ nF}$		6		V
	2/10 $\mu\text{s}$ , $I_{PP} = 100\text{ A}$ , $R_S = 50\ \Omega$ , $V_{GG} = -48\text{ V}$ , $C_G = 220\text{ nF}$		8		
	1.2/50 $\mu\text{s}$ , $I_{PP} = 53\text{ A}$ , $R_S = 47\ \Omega$ , $V_{GG} = -48\text{ V}$ , $C_G = 220\text{ nF}$		8		
	1.2/50 $\mu\text{s}$ , $I_{PP} = 96\text{ A}$ , $R_S = 52\ \Omega$ , $V_{GG} = -48\text{ V}$ , $C_G = 220\text{ nF}$		12		
$I_H$ Holding current	$I_T = -1\text{ A}$ , $di/dt = 1\text{ A/ms}$ , $V_{GG} = -48\text{ V}$	-150			$\text{mA}$
$I_{GKS}$ Gate reverse current	$V_{GG} = V_{GK} = V_{GKRM}, V_{KA} = 0$	$T_J = 25\text{ }^\circ\text{C}$		-5	$\mu\text{A}$
		$T_J = 85\text{ }^\circ\text{C}$		-50	$\mu\text{A}$
$I_{GT}$ Gate trigger current	$I_T = -3\text{ A}$ , $t_{p(g)} \geq 20\ \mu\text{s}$ , $V_{GG} = -48\text{ V}$			5	$\text{mA}$
$V_{GT}$ Gate-cathode trigger voltage	$I_T = -3\text{ A}$ , $t_{p(g)} \geq 20\ \mu\text{s}$ , $V_{GG} = -48\text{ V}$			2.5	V
$Q_{GS}$ Gate switching charge	1.2/50 $\mu\text{s}$ , $I_{PP} = -53\text{ A}$ , $R_S = 47\ \Omega$ , $V_{GG} = -48\text{ V}$ , $C_G = 220\text{ nF}$		0.1		$\mu\text{C}$
$C_{KA}$ Cathode-anode off-state capacitance	$f = 1\text{ MHz}$ , $V_d = 1\text{ V}$ , $I_G = 0$ , (see Note 3)	$V_D = -3\text{ V}$		100	$\text{pF}$
		$V_D = -48\text{ V}$		50	$\text{pF}$

NOTES: 3. These capacitance measurements employ a three terminal capacitance bridge incorporating a guard circuit. The unmeasured device terminals are a.c. connected to the guard terminal of the bridge.

## Thermal Characteristics

Parameter	Test Conditions	Min	Typ	Max	Unit
$R_{\theta JA}$ Junction to free air thermal resistance	$T_A = 25\text{ }^\circ\text{C}$ , EIA/JESD51-3 PCB, EIA/JESD51-2 environment, $P_{TOT} = 1.7\text{ W}$ D Package			120	$^\circ\text{C/W}$

Parameter Measurement Information

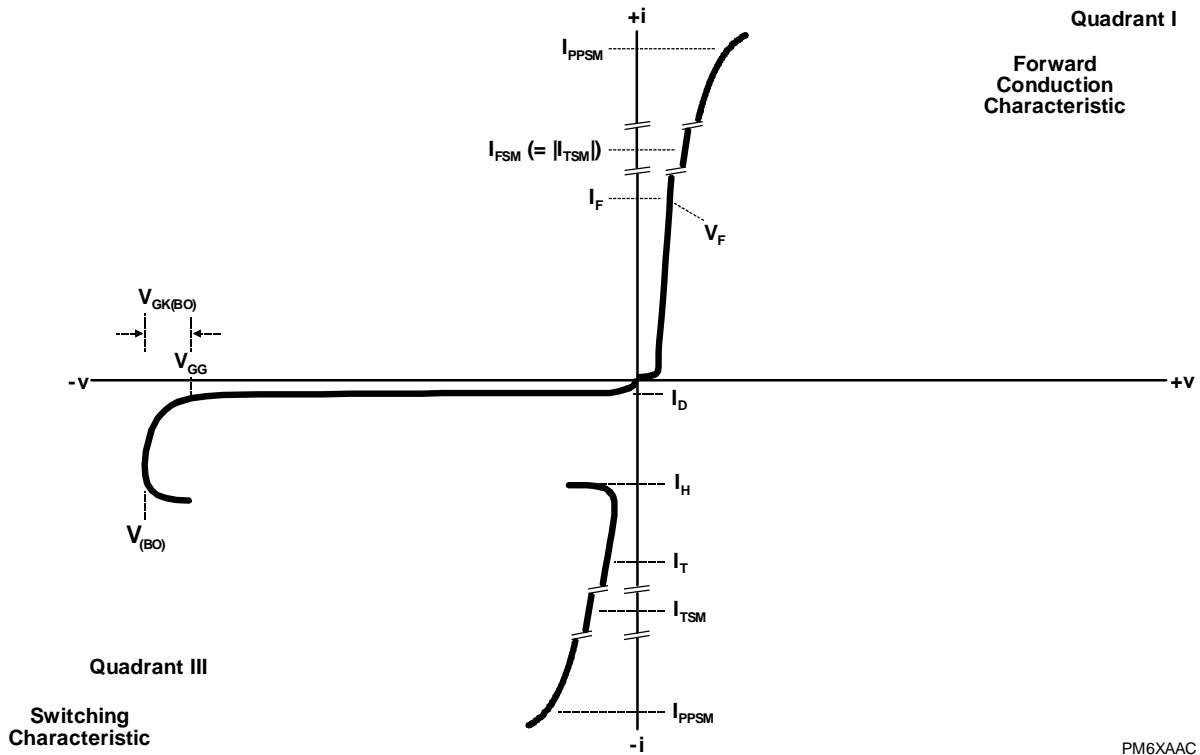

PM6XAAC

**Figure 1. Voltage-Current Characteristic**  
 Unless Otherwise Noted, All Voltages are Referenced to the Anode

Thermal Information

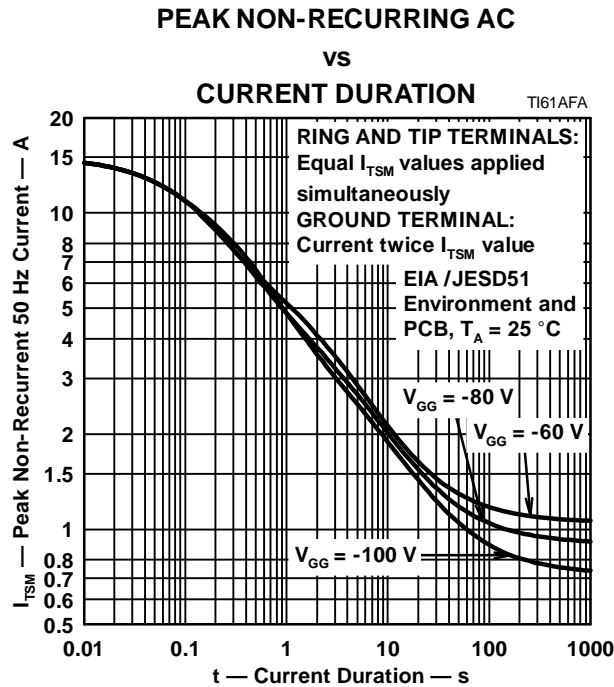

**Figure 2. Non-repetitive Peak On-State Current against Duration**  
(Gate Voltage Ranges are -20 V to -75 V for the '61089 and -20 V to -100 V for the '61089A)

## APPLICATIONS INFORMATION

## Gated Protectors

This section covers three topics. First, it is explained why gated protectors are needed. Second, the voltage limiting action of the protector is described. Third, an example application circuit is described.

## Purpose of Gated Protectors

Fixed voltage thyristor overvoltage protectors have been used since the early 1980s to protect monolithic SLICs (Subscriber Line Interface Circuits) against overvoltages on the telephone line caused by lightning, a.c. power contact and induction. As the SLIC was usually powered from a fixed voltage negative supply rail, the limiting voltage of the protector could also be a fixed value. The TISP1072F3 is a typical example of a fixed voltage SLIC protector.

SLICs have become more sophisticated. To minimize power consumption, some designs automatically adjust the supply voltage,  $V_{BAT}$ , to a value that is just sufficient to drive the required line current. For short lines the supply voltage would be set low, but for long lines, a higher supply voltage would be generated to drive sufficient line current. The optimum protection for this type of SLIC would be given by a protection voltage which tracks the SLIC supply voltage. This can be achieved by connecting the protection thyristor gate to the SLIC supply, Figure 3. This gated (programmable) protection arrangement minimizes the voltage stress on the SLIC, no matter what value of supply voltage.

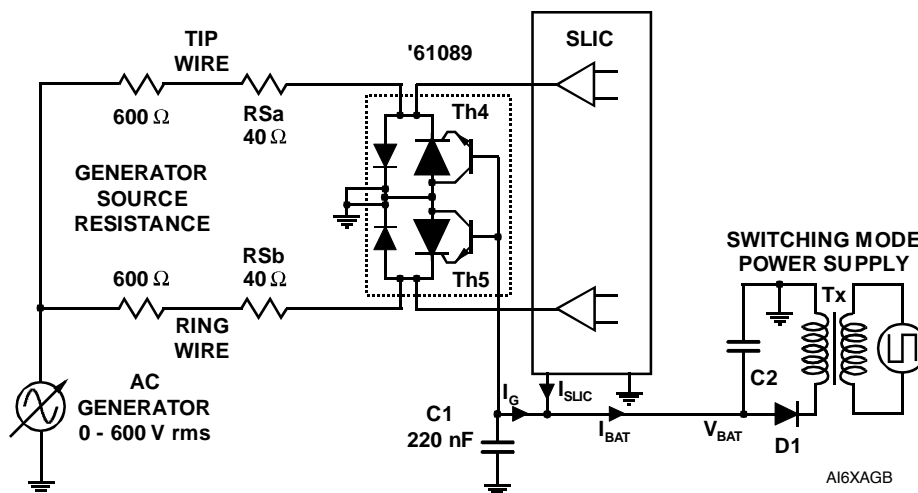

Figure 3. '61089 Buffered Gate Protector

## Operation of Gated Protectors

Figures 4 and 5 show how the '61089 device limits negative and positive overvoltages. Positive overvoltages (Figure 5) are clipped by the antiparallel diodes in the '61089 protector and the resulting current is diverted to ground. Negative overvoltages (Figure 4) are initially clipped close to the SLIC negative supply rail value ( $V_{BAT}$ ). If sufficient current is available from the overvoltage, then the protector (Th5) will crowbar into a low voltage on-state condition. As the overvoltage subsides the high holding current of the crowbar prevents d.c. latchup. The protection voltage will be the sum of the gate supply ( $V_{BAT}$ ) and the peak gate-cathode voltage ( $V_{GK(BO)}$ ). The protection voltage will be increased if there is a long connection between the gate decoupling capacitor, C1, and the gate terminal. During the initial rise of a fast impulse, the gate current ( $I_G$ ) is the same as the cathode current ( $I_K$ ). Rates of  $70 \text{ A}/\mu\text{s}$  can cause inductive voltages of 0.7 V in 2.5 cm of printed wiring track. To minimize this inductive voltage increase of protection voltage, the length of the capacitor to gate terminal tracking should be minimized. Inductive voltages in the protector cathode wiring will also increase the protection voltage. These voltages can be minimized by routing the SLIC connection through the protector as shown in Figure 3.

## Application Circuit

Figure 6 shows a typical '61089 part SLIC card protection circuit. The incoming line conductors, Ring (R) and Tip (T), connect to the relay matrix via the series overcurrent protection. Fusible resistors, fuses and positive temperature coefficient (PTC) thermistors can be used for overcurrent protection. Resistors will reduce the prospective current from the surge generator for both the '61089 device and the ring/test

## APPLICATIONS INFORMATION

### Application Circuit (Continued)

protector. The TISP7xxxF3 protector has the same protection voltage for any terminal pair. This protector is used when the ring generator configuration may be ground or battery-backed. For dedicated ground-backed ringing generators, the TISP3xxxF3 gives better protection as its inter-conductor protection voltage is twice the conductor to ground value.

Relay contacts 3a and 3b connect the line conductors to the SLIC via the '61089 protector. The protector gate reference voltage comes from the SLIC negative supply ( $V_{BAT}$ ). A 220 nF gate capacitor sources the high gate current pulses caused by fast rising impulses.

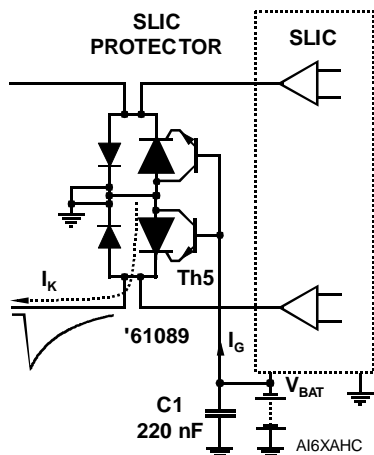

Figure 4. Negative Overvoltage Condition

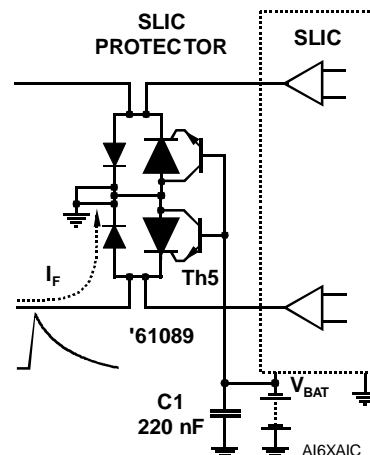

Figure 5. Positive Overvoltage Condition

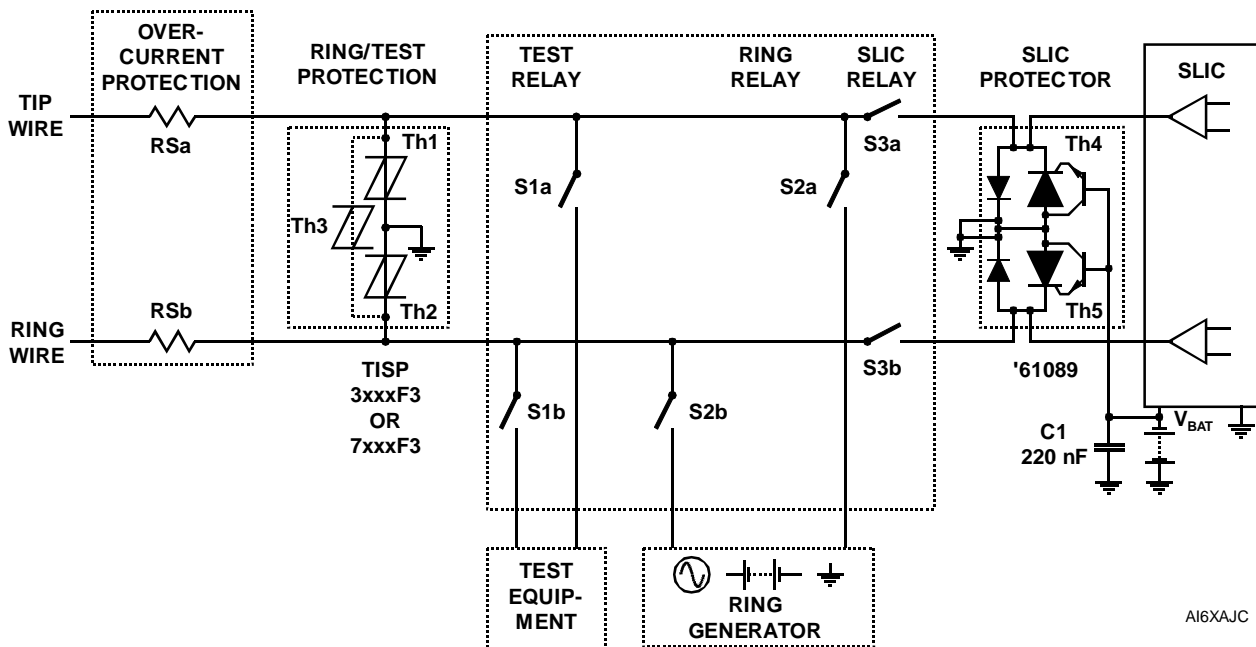

Figure 6. Typical Application Circuit

## MECHANICAL DATA

### Device Symbolization Code

Devices will be coded as below.

Device	Symbolization Code
TISP61089DR-S	P61089
TISP61089SDR-S	61089S
TISP61089ADR-S	61089A
TISP61089ASDR-S	1089AS

## BOURNS®

**Asia-Pacific:** Tel: +886-2 2562-4117 • Email: [asiacus@bourns.com](mailto:asiacus@bourns.com)

**EMEA:** Tel: +36 88 885 877 • Email: [eurocus@bourns.com](mailto:eurocus@bourns.com)

**The Americas:** Tel: +1-951 781-5500 • Email: [americus@bourns.com](mailto:americus@bourns.com)

[www.bourns.com](http://www.bourns.com)

"TISP" is a trademark of Bourns, Ltd., a Bourns Company, and is Registered in the U.S. Patent and Trademark Office.  
"Bourns" is a registered trademark of Bourns, Inc. in the U.S. and other countries.

NOVEMBER 1995 – REVISED JULY 2019

Specifications are subject to change without notice.

Users should verify actual device performance in their specific applications.

The products described herein and this document are subject to specific legal disclaimers as set forth on the last page of this document, and at [www.bourns.com/docs/legal/disclaimer.pdf](http://www.bourns.com/docs/legal/disclaimer.pdf).

This legal disclaimer applies to purchasers and users of Bourns® products manufactured by or on behalf of Bourns, Inc. and its affiliates (collectively, "Bourns").

Unless otherwise expressly indicated in writing, Bourns® products and data sheets relating thereto are subject to change without notice. Users should check for and obtain the latest relevant information and verify that such information is current and complete before placing orders for Bourns® products.

The characteristics and parameters of a Bourns® product set forth in its data sheet are based on laboratory conditions, and statements regarding the suitability of products for certain "typical" applications are based on Bourns' knowledge of typical requirements in generic applications. Bourns assumes that "typical" applications include failsafe/backup features to address critical risks to users and are designed to allow rework of Bourns® product to avoid scrap of a device solely due to malfunctioning Bourns® product. The characteristics and parameters of a Bourns® product in a user application may vary from the data sheet characteristics and parameters due to (i) the combination of the Bourns® product with other components in the user's application, or (ii) the environment of the user application itself. The characteristics and parameters of a Bourns® product also can and do vary in different applications and actual performance may vary over time. Thus, users should always verify the actual performance of the Bourns® product in their specific devices and applications and make their own independent judgments regarding the suitability of Bourns® product and the amount of additional test margin to design into their device or application to compensate for differences between laboratory and real-world conditions.

Unless Bourns has explicitly designated an individual Bourns® product as meeting the requirements of a particular industry standard (e.g., IATF 16949) or a particular qualification (e.g., UL listed or recognized), Bourns is not responsible for any failure of an individual Bourns® product to meet the requirements of such industry standard or particular qualification even if such industry standard or qualification is a "state of art". Users of Bourns® products are responsible for ensuring compliance with safety-related requirements and standards applicable to their devices or applications.

Bourns® products are not recommended, authorized or intended for use in applications where failure or malfunction may result in personal injury, death, or severe property or environmental damage, such as without limitation nuclear, life-critical medical and certain automotive and aviation applications. Except as set forth in the bullet points below or unless expressly and specifically approved in writing on a case-by-case basis by an authorized Bourns' representative, use of any Bourns® products in such unauthorized high-risk applications is at the user's sole risk.

- Bourns considers implantable/invasive devices and devices/procedures designed as life-supporting or life-sustaining by the U.S. Food and Drug Administration or equivalent organizations outside of the United States as "life-critical" medical applications. Bourns expressly identifies those Bourns® standard products that are suitable for use in typical medical applications that are not life-critical in its publication entitled "Bourns Medical Grade Component Guide."
- Bourns expressly identifies those Bourns® standard products that are suitable for use in typical automotive applications associated with any Automate Safety Integrity Level (ASIL) in its publication entitled "Bourns Automotive Grade Component Guide." Bourns' designation of Bourns® product as compliant with the AEC-Q standard does not by itself mean that Bourns has approved such product for use in an automotive application.
- Bourns expressly identifies Bourns® standard products that are suitable for use in the typical aviation applications/systems requiring System Design Assurance Level (RTCA DO-254 DAL) of C, D or E in its publication entitled "Bourns Civilian Aerospace/Aviation Grade Component Guide." Bourns does not test its products for compliance with United States Federal Aviation Administration standards or any other generally equivalent governmental organization standard applicable to products designed or manufactured for use in aviation applications. Use of Bourns® standard components in aviation applications associated with RTCA DO-254 DAL A or B without proper approval noted above shall be at the user's sole risk.
- Bourns will review and authorize on a case-by-case basis the use of Bourns® standard products which are at least AEC-Q compliant in space-related civil applications (rockets, satellites) with a negotiated cross-waiver and indemnity agreement.

The use and level of testing applicable to Bourns® custom products shall be negotiated on a case-by-case basis by Bourns and the user for which such Bourns® custom products are specially designed. Absent a written agreement between Bourns and the user regarding the use and level of such testing, the above provisions applicable to Bourns® standard products shall also apply to such Bourns® custom products.

Use of Bourns® products or Bourns' technology in military/defense applications must be reviewed with Bourns for compliance with applicable export control laws and embargoes. Users shall not sell, transfer, export or re-export (which includes transfers within a country) any Bourns® products or technology or technical data for use in activities which involve the design, development, production, use or stockpiling of nuclear, chemical or biological weapons or missiles, nor shall they use Bourns® products or technology or technical data in any facility which engages in activities relating to such devices. Further, Bourns® products and Bourns' technology and technical data may not under any circumstance be exported or re-exported to countries subject to international sanctions or embargoes. Bourns® products and technology may not, without prior authorization from Bourns and/or the Government of a country where such product/technology is designed and/or manufactured, be resold, transferred, or re-exported (including within the same country) to any party not eligible to receive commodities, software, and technical data originating in such country.

To the maximum extent permitted by applicable law, Bourns disclaims (i) any and all liability for special, punitive, consequential, incidental or indirect damages or lost revenues or lost profits, and (ii) any and all implied warranties (those not based on parameters specified in Bourns' data sheets and/or specifications), including implied warranties of fitness for particular purpose, non-infringement and merchantability.

For your convenience, copies of this Legal Disclaimer Notice with German, Spanish, Japanese, Traditional Chinese and Simplified Chinese bilingual versions are available at:

Web Page: <https://www.bourns.com/legal/disclaimers-terms-and-policies>

PDF: <https://www.bourns.com/docs/Legal/disclaimer.pdf>