



## Features

- Formerly a Riedon™ product
- 24-bit isolated shunt current sensor with CANbus interface
- 1500 VDC reinforced galvanic isolation
- 16-bit +150 °C microcontroller
- 24-bit ADC with buffered analog inputs
- ECC flash memory with autocorrect single bit errors

- Internal and external CRC data error detection
- Advanced non-linear temperature compensation
- Assembled using AEC-Q compliant components (optional for Model SSD-1000A only)
- RoHS compliant\*

## SSD-CANbus Series – Digital Current Sensor with CANbus Interface

### Specifications

Characteristic	SSD-100A	SSD-250A	SSD-500A	SSD-1000A
Nominal Current (A)	±100	±250	±500	±1000
Peak Current (No Clipping)	+2 kA / -1 kA	+5 kA / -2.5 kA	+10 kA / -5 kA	+20 kA / -10 kA
Shunt Resistance ( $\mu\Omega$ ) Excluding primary termination resistance	300	120	60	30
Initial Accuracy	< ±0.1 %			
Linearity Over Current Range	< ±0.1 % + 5 mA	< ±0.1 % + 13 mA	< ±0.1 % + 25 mA	< ±0.1 % + 50 mA
Bandwidth	5 kHz			
ADC Resolution	24 bits			
Speed (readings per second)	up to 1100 rps (0.9 - 4200 ms per reading)			
Supply Voltage	5 - 60 VDC			
Typical Supply Voltage (See Shunt Supply Voltage Requirements on Page 2)	* @ 5.0 V, 55 mA typical		** @ 24 V, 15 mA typical	
DC Bus Voltage Range	±1200 VDC max. (10 M input impedance)			
CAN Interface	CAN 2.0 A Speeds: 125 K, 250 K, 500 K (default), 1 M baud			
Long Term Stability	< ±0.3 % 1000 hours 115 °C terminal temperature			
Galvanic Isolation	1500 VDC 1000 VAC RMS (maximum continuous working voltage)			
Dielectric Strength	3500 VAC RMS 1 minute			
Operating Temperature	-40 °C to +115 °C ambient -40 °C to +125 °C primary conductor (see derating curve on page 2)			
Storage Temperature	-55 °C to +125 °C			
Assembled using AEC-Q Compliant Components	-	-	-	✓

### Materials (RoHS Compliant)

Resistance Element.....CuMnNi  
Current Terminal<sup>1</sup>....Nickel-plated copper  
Electronics Housing.....94-V0 rated

Note:

<sup>1</sup> Suitable for copper, copper-clad aluminum or aluminum conductors

### Product Safety Notice

The SSD Series Digital Current Sensor must be used in a manner specified by this data sheet, otherwise the protection provided by the equipment may be impaired. The SSD Series should not be treated as a structural part of the installation and must be properly supported on both ends.

### Additional Information

Click these links for more information:



**CALIFORNIA WARNING:** Can expose you to lead, a carcinogen and reproductive toxicant.

See [www.P65Warnings.ca.gov](http://www.P65Warnings.ca.gov)

\*RoHS Directive 2015/863, Mar 31, 2015 and Annex. Specifications are subject to change without notice.

Users should verify actual device performance in their specific applications.

The products described herein and this document are subject to specific legal disclaimers as set forth on the last page of this document, and at [www.bourns.com/docs/legal/disclaimer.pdf](http://www.bourns.com/docs/legal/disclaimer.pdf).

## Applications

- EV charging stations
- Battery systems
- Renewable energy
- Motor drives

## SSD-CANbus Series – Digital Current Sensor with CANbus Interface

**BOURNS®**

### Specifications (continued)

Model	Typical Noise (mA RMS) per ADC Reading Interval (ms), 1.25X Range, Zero Current															
	0.9	1.6	3.2	4.8	6.4	7.2	9	13	26	51	102	205	410	820	1640	3280
SSD-100A	3	3	2	2	2	2	1	1	1	1	1	<1	<1	<1	<1	<1
SSD-250A	8	7	6	5	5	4	4	3	3	2	2	1	1	1	<1	<1
SSD-500A	15	13	12	11	10	9	7	7	5	4	3	2	2	1	1	1
SSD-1000A	31	27	24	21	19	17	15	13	11	9	6	4	3	2	2	1

### Shunt Supply Voltage Requirements

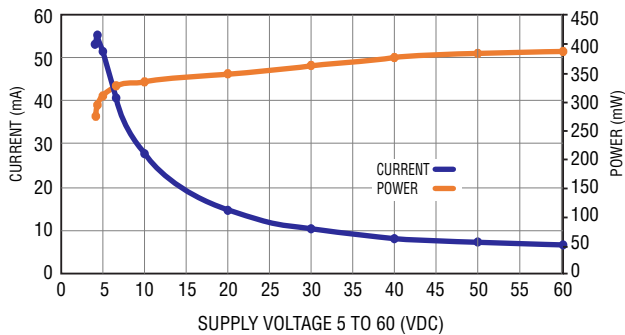

\* @5.0 V, 55 mA (SSD-100A and SSD-250A only)

\*\* @24 V, 15 mA (SSD-500A and SSD-1000A only)

### Overcurrent vs. Time

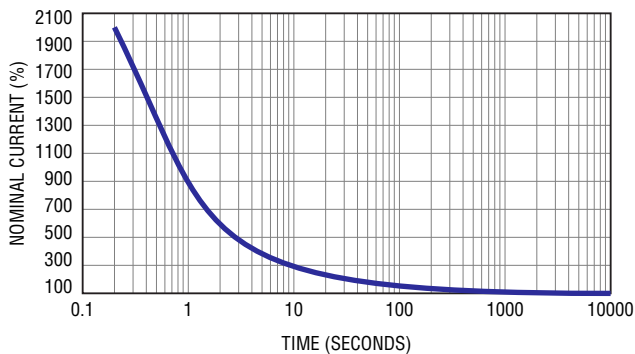

### Derating Curve

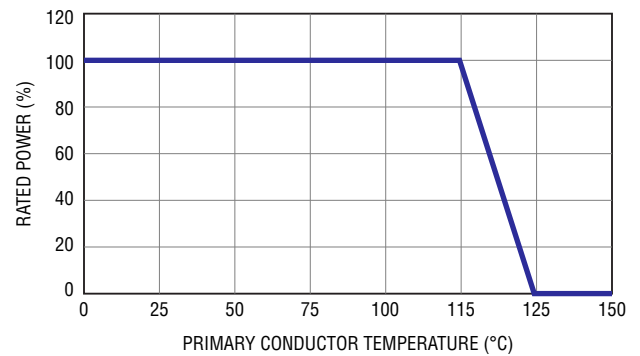

### Connectors

SSD Connector	Mating Connector	Molex Nano-Fit Part Number
4-Pin Male	4-Pin Female	1053071204
	0-22 AWG Female Contacts*	1053002200
	4-Pin TPA Strain Relief	1053251004
2-Pin Male Vbus	2-Pin Female	1053071202
	20-22 AWG Female Contacts*	1053002200
	2-Pin TPA Strain Relief	1053251002

\* Use Gold (Au) plated contacts for 115 °C temperature rating.

### How to Order

**SSD - 100A - C - T**

Model \_\_\_\_\_

Amps \_\_\_\_\_  
 100A = 100 A    250A = 250 A    500A = 500 A    1000A = 1000 A

Interface \_\_\_\_\_  
 C = CANbus (Industrial Version)  
 CA = CANbus (Assembled Using AEC-Q Compliant Components - Model SSD-1000A Only)

Option \_\_\_\_\_  
 Blank = Standard  
 -T = Internal 120 Ω Termination Resistor (Industrial Version Only)

Specifications are subject to change without notice.

Users should verify actual device performance in their specific applications.

The products described herein and this document are subject to specific legal disclaimers as set forth on the last page of this document, and at [www.bourns.com/docs/legal/disclaimer.pdf](http://www.bourns.com/docs/legal/disclaimer.pdf).

Product Dimensions

SSD-100A to SSD-500A

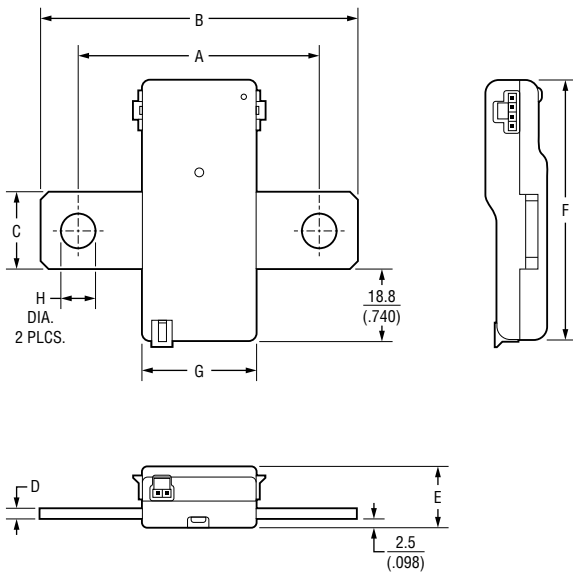

SSD-1000A

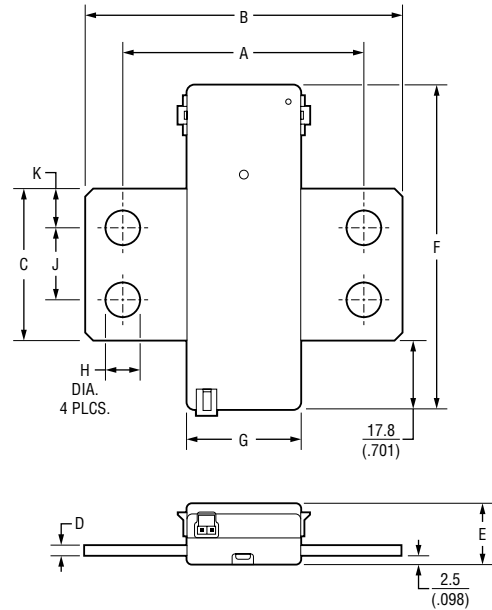

Model	SSD-100A	SSD-250A	SSD-500A	SSD-1000A
A	$\frac{63.5 \pm 0.5}{(2.50 \pm .020)}$			
B	$\frac{84 \pm 0.5}{(3.307 \pm .020)}$			
C	$\frac{20 \pm 0.5}{(.787 \pm .020)}$		$\frac{40 \pm 0.5}{(1.575 \pm .020)}$	
D	$\frac{3 \pm 0.5}{(.118 \pm .020)}$		$\frac{4 \pm 0.5}{(.157 \pm .020)}$	
E	$\frac{16.4 \pm 0.5}{(.646 \pm .020)}$		$\frac{17.4 \pm 0.5}{(.685 \pm .020)}$	
F	$\frac{68.8 \pm 0.5}{(2.709 \pm .020)}$		$\frac{85.8 \pm 0.5}{(3.378 \pm .020)}$	

Model	SSD-100A	SSD-250A	SSD-500A	SSD-1000A
G	$\frac{30.8 \pm 0.5}{(1.213 \pm .020)}$			
H	$\frac{8.7 \pm 0.5}{(.343 \pm .020)}$			
J	-	-	-	$\frac{19 \pm 0.3}{(.748 \pm .012)}$
K	-	-	-	$\frac{10.5 \pm 0.3}{(.413 \pm .012)}$

DIMENSIONS:  $\frac{\text{MM}}{\text{(INCHES)}}$

Specifications are subject to change without notice.

Users should verify actual device performance in their specific applications.

The products described herein and this document are subject to specific legal disclaimers as set forth on the last page of this document, and at [www.bourns.com/docs/legal/disclaimer.pdf](http://www.bourns.com/docs/legal/disclaimer.pdf).

**Installation**

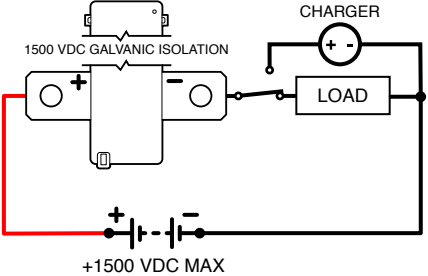
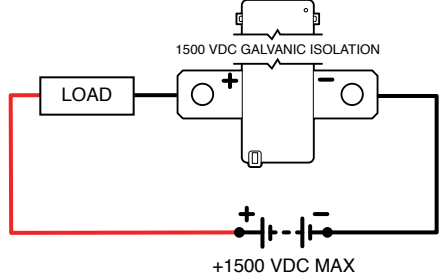
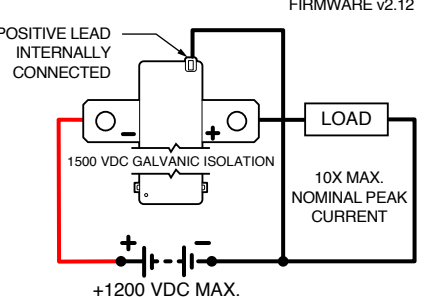
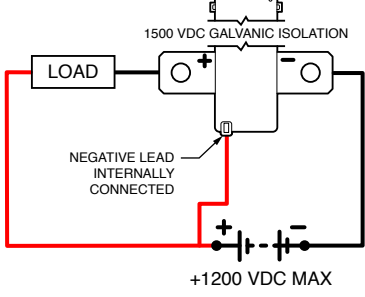
Electrical Wiring		
	High Side	Low Side
<p>Current Only ±1500 VDC MAX.</p>	 <p>The diagram shows a high-side current measurement setup. A DC power source labeled '+1500 VDC MAX' is connected to the positive terminal of a 1500 VDC GALVANIC ISOLATION sensor. The negative terminal of the sensor is connected to a 'LOAD' and a 'CHARGER' in parallel. The other side of the load and charger is connected to the negative terminal of the power source.</p>	 <p>The diagram shows a low-side current measurement setup. A DC power source labeled '+1500 VDC MAX' is connected to the positive terminal of a 1500 VDC GALVANIC ISOLATION sensor. The negative terminal of the sensor is connected to a 'LOAD'. The other side of the load is connected to the negative terminal of the power source.</p>
<p>Bus Voltage Measurements ±1200 VDC</p>	 <p>The diagram shows a high-side bus voltage measurement setup. A DC power source labeled '+1200 VDC MAX' is connected to the positive terminal of a 1500 VDC GALVANIC ISOLATION sensor. The negative terminal of the sensor is connected to a 'LOAD'. The other side of the load is connected to the positive terminal of the power source. The sensor's positive terminal is also connected to the positive terminal of the power source. Labels include 'POSITIVE LEAD INTERNALLY CONNECTED', 'FIRMWARE v2.12', and '10X MAX. NOMINAL PEAK CURRENT'.</p> <p>Use SETMODE Command to Invert Current and Voltage. Keep Positive DC Connection Short to Minimize Bus Voltage Drop Errors.</p>	 <p>The diagram shows a low-side bus voltage measurement setup. A DC power source labeled '+1200 VDC MAX' is connected to the positive terminal of a 1500 VDC GALVANIC ISOLATION sensor. The negative terminal of the sensor is connected to a 'LOAD'. The other side of the load is connected to the positive terminal of the power source. The sensor's negative terminal is also connected to the negative terminal of the power source. Labels include 'NEGATIVE LEAD INTERNALLY CONNECTED'.</p> <p>Keep Negative DC Connection Short to Minimize Bus Voltage Drop Errors.</p>

Specifications are subject to change without notice.

Users should verify actual device performance in their specific applications.

The products described herein and this document are subject to specific legal disclaimers as set forth on the last page of this document, and at [www.bourns.com/docs/legal/disclaimer.pdf](http://www.bourns.com/docs/legal/disclaimer.pdf).

**Connectors**

Connectors on both sides have same pinout. Either or both connectors can be used.

**CANbus**

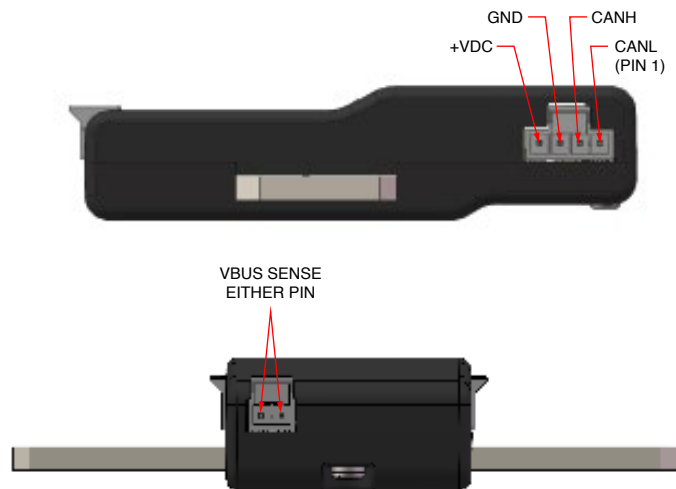

## Optional Base Mounting Fixtures

### SSA-BASE

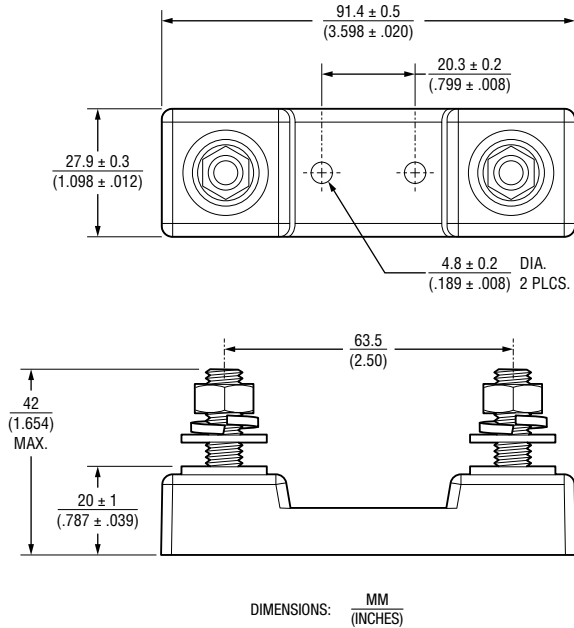

### SSA-BASE-1K

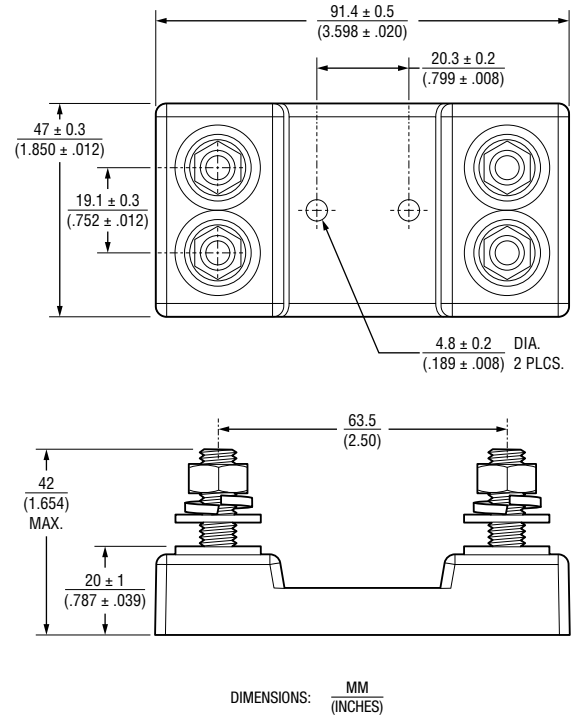

- Robust design
- 5/16-18 Stainless Steel Hardware
- Torque Nuts:  
11-13 ft-lb (15-17.6 N-m)
- UL 94-V0 rated materials

## Optional SS-CABLE Power / Serial Connection

### SS-CABLE-1M



Serial Output		
White	CANL / 485A	Pin 1
Yellow	CANH / 485B	Pin 2
Black	Ground	Pin 3
Red	+5 to 60 VDC	Pin 4

- For all SSD models
- Color-coded 22 ga wire
- Two twisted pairs
- 1 meter standard length

Specifications are subject to change without notice.

Users should verify actual device performance in their specific applications.

The products described herein and this document are subject to specific legal disclaimers as set forth on the last page of this document, and at [www.bourns.com/docs/legal/disclaimer.pdf](http://www.bourns.com/docs/legal/disclaimer.pdf).

## Optional SSD Connector Sets

### SSD-CONN-SET

Standard Connector Set		
Includes	Molex P/N	Description
1 pc.	1053071204	4-Pin Female
1 pc.	1053071202	2-Pin Female
6 pcs.	1053002200	20-22 AWG Female Crimp Terminals
1 pc.	1053251004	4-Pin TPA
1 pc.	1053251002	2-Pin TPA

## Optional SSD Serial Connection Kit

### SSD-SERKIT

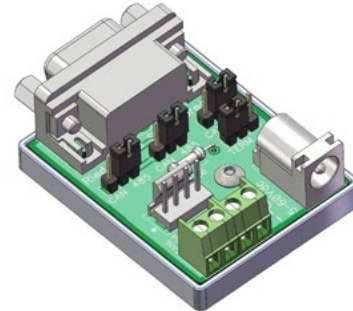

Serial Connection Kit	
Includes	Description
1 pc.	SSD to DB-9F Serial Adapter
1 pc.	5 VDC USB Power Cable
1 pc.	4-Pin Programming Cable (1 m Length)

The SSD serial connection kit simplifies the initial setup of the SSD Series Digital Current Sensor. It includes the necessary components to connect USB to CAN and USB to RS-485 serial adapters that have a 9-pin DB-9 male output connector. It includes jumpers to switch from RS-485 to CANbus and enable a termination resistor. USB to serial adapter not included.

USB to RS-485 Adapter - From DTEK, StarTech and others with RS-485 on DB9 pins 1 and 2 and the ground on pin 5. Note: Some adapters have the 485A and 485B pins reversed.

USB to CANbus adapter - From PEAK, Kvaser and others with CAN on DB9 pins 2 and 7 and the ground on pin 3.

**Frequently Asked Questions**

**Q: Is it necessary to install the SSD Series on the low side of the circuit?**

**A:** The SSD Series Digital Current Sensor is completely isolated, so it may be installed in either the low or high side of the circuit.

**Q: The sensor is only sending whole Coulombs and Watt-hours, how precise are these?**

**A:** Internally, micro-coulombs and micro-joules are counted; so very short ADC timing intervals and very low currents are accurately counted.

**Q: What is the best way to connect to the SSD Series terminals?**

**A:** Make sure connections are clean and well prepared. Bolts to be torqued to the hardware manufacturer’s recommendations. There should be sufficient clamping force to ensure proper connection. Overlap shown below should be taken as a minimum. Suitable for Copper, Copper-Clad Aluminum or Aluminum conductors.

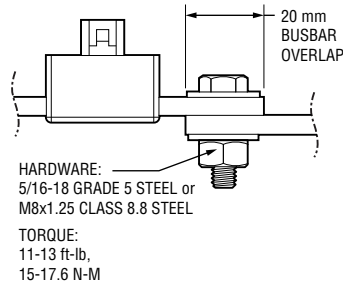

**Q: What is the best way to cool the SSD Series Digital Current Sensor?**

**A:** A majority of the heat generated by the SSD Series is dissipated through the primary conductors. Care should be taken to ensure that the primary conductors are sized appropriately given expected amperage and conductor length. Bourns recommends a 115 °C maximum conductor temperature at rated current. If there are thermal concerns, oversizing the conductors will help minimize the operating temperature of the Digital Current Sensor.

**Q: When should I use the SSD version with the internal 120 Ω termination resistor (-T)?**

**A:** The -T version includes a built-in 120 Ω resistor between CANH/CANL or 485A/485B. Typical RS485 or CANbus networks require termination at two endpoints. Use the -T version accordingly. Avoid using more than two termination points to ensure proper communication.

**Q: What size wire is suitable for the SSD Series?**

**A:**

Copper Conductor Ampacity Ratings (continuous)					
mm <sup>2</sup>	AWG	Amps (75 °C)	mm <sup>2</sup>	AWG	Amps (75 °C)
13.3	6	65	107	0000 (4/0)	230
21.2	4	85	127	250 MCM	255
33.6	2	115	152	300 MCM	285
42.4	1	130	203	400 MCM	335
54	0 (1/0)	150	253	500 MCM	380
67	00 (2/0)	175	380	750 MCM	475
85	000 (3/0)	200	887	1500 MCM	625

Specifications are subject to change without notice.

Users should verify actual device performance in their specific applications.

The products described herein and this document are subject to specific legal disclaimers as set forth on the last page of this document, and at [www.bourns.com/docs/legal/disclaimer.pdf](http://www.bourns.com/docs/legal/disclaimer.pdf).

SSD Interface Manual

**SSD CAN IDs for Settings (Defaults)**

Default Baud 500 kbp/s

SET COMMAND ID	0x3FA	Motorola	Used to Write values
GET COMMAND ID	0x3FB	Motorola	Used to Read values
REPLY ID	0x3FC	Motorola	Returned Data from Get Command

**CAN IDs for Sensor Readings (Defaults)**

CURRENT	0x3F1	Intel	Sensor Current
TEMPERATURE	0x3F2	Intel	Sensor Temperature
VBUS	0x3F3	Intel	Bus Voltage
COULOMB	0x3F4	Intel	Coulomb Counter
POWER	0x3F5	Intel	Power
ENERGY	0x3F6	Intel	Energy Counter
ERRORS/ALERT	0x3F7	Intel	Errors or Alerts

Intel (Data Byte 0 = LSB) data format for Sensor Readings  
 Motorola (Data Byte 0 = MSB) data format for all Settings to improve legibility with setup

Name	Size	Units	Range	Format
Current	Signed int32	1 mA	± 20 X Nominal	Intel
Temperature	Signed int32	0.1 °C	-40 °C to +125 °C*	Intel
Bus Voltage (Vbus)	Signed int32	1 mV	± 1200 V <sub>DC</sub>	Intel
Coulomb	Signed int64	1C (A*s)	± 2 <sup>60</sup>	Intel
Power	Unsigned int32	0.1 W	0 to 2 <sup>32</sup>	Intel
Energy	Unsigned int64	W*h	0 to 2 <sup>60</sup>	Intel

**COMMAND LIST**

GET ALL ENABLED	0x00 - Read Only	VBUS UNDER LIMIT	0x1B
GET CURRENT	0x01 - Read Only	VBUS OVER LIMIT	0x1C
GET TEMPERATURE	0x02 - Read Only	POWER OVER LIMIT	0x1D
GET VBUS	0x03 - Read Only	SHUNT NANO-OHM	0x1E
GET COULOMB	0x04 - Read Only	CURRENT ZERO OFFSET	0x21
GET POWER	0x05 - Read Only	VBUS FACTOR	0x22
GET ENERGY	0x06 - Read Only	VBUS ZERO OFFSET	0x23
GET ERRORS	0x07 - Read Only	TEMP OFFSET	0x24
RESET COMMAND	0x10 - Write Only	T0 TEMP COMPENSATION	0x25 - Read Only
SET CAN IDS	0x11 - Write Only	T1 TEMP COMPENSATION	0x26 - Read Only
SETMODE	0x12	T2 TEMP COMPENSATION	0x27 - Read Only
BAUDRATE	0x14	RESET CAUSES	0x28 - Read Only
READING DELAY	0x16	FIRMWARE VERSION	0x30 - Read Only
A2D CONFIG	0x17	SERIAL NUMBER	0x31 - Read Only
CURRENT UNDER LIMIT	0x18		
CURRENT OVER LIMIT	0x19		
TEMP OVER LIMIT	0x1A		

Specifications are subject to change without notice.  
 Users should verify actual device performance in their specific applications.  
 The products described herein and this document are subject to specific legal disclaimers as set forth on the last page of this document, and at [www.bourns.com/docs/legal/disclaimer.pdf](http://www.bourns.com/docs/legal/disclaimer.pdf).

**SSD Interface Manual (continued)**
**0x00 – Command GET ALL ENABLED – Read Only**

Used to get all enabled readings in the SETMODE command. Current, Temperature, Vbus, etc...

	Message ID	Length	Data Fields (LSB First)					
SEND	0x3FB	0x01	0x00					
RECEIVE	Multiple replies from all enabled readings in the SETMODE Command							

**0x01 – Command GET CURRENT – Read Only**

Used to get the last sensor current reading in milliamps.

Reply is 4 bytes from CAN ID 0x3F1 (default) - Intel Format (Data Byte 0 = LSB)

	Message ID	Length	Data Fields (LSB First)					
SEND	0x3FB	0x01	0x01					
RECEIVE	0x3F1	0x04	0xFF	0xFF	0xFF	0xFF		

**0x02 – Command GET TEMPERATURE – Read Only**

Used to get the last sensor temperature reading in 0.1 centigrade.

Reply is 4 bytes from CAN ID 0x3F2 (default) - Intel Format (Data Byte 0 = LSB)

	Message ID	Length	Data Fields (LSB First)					
SEND	0x3FB	0x01	0x02					
RECEIVE	0x3F2	0x04	0xFF	0xFF	0xFF	0xFF		

**0x03 – Command GET VBUS – Read Only**

Used to get the last external bus voltage reading in milli-Volts.

Reply is 4 bytes from CAN ID 0x3F3 (default) - Intel Format (Data Byte 0 = LSB)

	Message ID	Length	Data Fields (LSB First)					
SEND	0x3FB	0x01	0x03					
RECEIVE	0x3F3	0x04	0xFF	0xFF	0xFF	0xFF		

**SSD Interface Manual (continued)**

**0x04 – Command GET COULOMB – Read / Write**

Used to get or set the last coulomb count which is continuously updated with current.

Note: The coulomb reading can overflow! It is up to the user to check if very large values ( $> \pm 2^{60}$ ) are expected. See 0x07 command to read overflow bit.

Reply is 8 bytes from CAN ID 0x3F4 (default) - Intel Format (Data Byte 0 = LSB)

Note: Writing a new value is limited to signed int32 values.

Example: Write 500,000 (0x7A120) to coulomb counter

**Write Message**

	Message ID	Length	Data Fields					
SEND	0x3FA	0x05	0x04	0x00	0x07	0xA1	0x20	
RECEIVE	(none)							

**Read Message**

	Message ID	Length	Data Fields (LSB First)							
SEND	0x3FB	0x01	0x04							
RECEIVE (int64)	0x3F4	0x08	0XX	0XX	0XX	0XX	0XX	0XX	0XX	0XX

**0x05 – Command GET POWER – Read Only**

Used to get the last power reading in 0.1 watts.

Reply is 4 bytes from CAN ID 0x3F5 (default) - Intel Format (Data Byte 0 = LSB)

	Message ID	Length	Data Fields (LSB First)							
SEND	0x3FB	0x01	0x05							
RECEIVE	0x3F5	0x04	0XX	0XX	0XX	0XX				

**0x06 – Command GET ENERGY – Read Only**

Used to get the last energy count in Watt-hours (Wh) which is continuously updated.

Note: The energy reading can overflow! It is up to the user to check if very large values ( $> 2^{60}$ ) are expected. See 0x07 command to read overflow bit.

Reply is 8 bytes from CAN ID 0x3F6 (default) - Intel Format (Data Byte 0 = LSB)

	Message ID	Length	Data Fields (LSB First)							
SEND	0x3FB	0x01	0x06							
RECEIVE (int64)	0x3F6	0x08	0XX	0XX	0XX	0XX	0XX	0XX	0XX	

Specifications are subject to change without notice.

Users should verify actual device performance in their specific applications.

The products described herein and this document are subject to specific legal disclaimers as set forth on the last page of this document, and at [www.bourns.com/docs/legal/disclaimer.pdf](http://www.bourns.com/docs/legal/disclaimer.pdf).

**SSD Interface Manual (continued)**

**0x07** – Command GET ERRORS/Alerts – Read Only

Used to get any errors or alerts which are continuously updated.

Reply is 2 bytes from CAN ID 0x3F7 (default) - Motorola Format (Big Endian)

	Message ID	Length	Data Fields (LSB First)				
SEND	0x3FB	0x01	0x07				
RECEIVE	0x3F7	0x02	0xFF	0xFF			

Returned ERROR / ALERT bits															
15	14	13	12	11	10	9	8	7	6	5	4	3	2	1	0
N/A	1 = ECC Single Bit	1 = EEPROM Corrupt	1 = EEPROM RW	1 = ADC Initialization	1 = ADC CRC Read	1 = Energy Overflow	1 = Coulomb Overflow	1 = Power Over Limit	1 = Vbus Over Limit	1 = Vbus Under Limit	1 = Temp Over Limit	1 = Current Over Limit	1 = Current Under Limit	1 = Current Range Over	1 = Vbus Range Over

Bit0 Vbus Range Over – Bus Voltage exceeds the MAX voltage for the range selected, see **0X17** command.

Bit1 Current Range Over – Peak current exceeded the range selected, see **0X17** command.

Bit2 Current Under Limit – Current is below the limit set, see **0X18** command.

Bit3 Current Over Limit – Current is above the limit set, see **0X19** command.

Bit4 Temp Over Limit – Temperature is above +125 °C or the limit set, see **0X1A** command.

Bit5 Vbus Under Limit – Bus Voltage is below the limit set, see **0X1B** command.

Bit6 Vbus Over Limit – Bus Voltage is above the limit set, see **0X1C** command.

Bit7 Power Over Limit – Power is above the limit set, see **0X1D** command.

Bit8 Coulomb Overflow – Coulombs have exceeded the range of  $\pm 2^{47}$ .

Bit9 Energy Overflow – Energy has exceeded  $2^{48}$ .

Bit10 ADC CRC Read – The ADC’s CRC doesn’t match the calculated CRC of the returned data.

Bit11 ADC Initialization – The ADC’s initialized registers don’t match the written values.

Bit12 EEPROM R/W – Error reading or writing to the internal EEPROM.

Bit13 EEPROM Corrupt – The EEPROM CRC doesn’t match saved value.

Bit14 ECC Single Bit Error – Flash Memory had an Auto-Correctable Error.

Specifications are subject to change without notice.

Users should verify actual device performance in their specific applications.

The products described herein and this document are subject to specific legal disclaimers as set forth on the last page of this document, and at [www.bourns.com/docs/legal/disclaimer.pdf](http://www.bourns.com/docs/legal/disclaimer.pdf).

**SSD Interface Manual (continued)**

**0x10 – Command RESET COMMAND – Write Only**

Rebooting will restore previously saved settings if current settings are not saved. This will prevent baud rate or address errors since you will need to connect with the new values before you can issue the save to EEPROM command.

0x0001 – Reset Coulomb and Energy counters

0x0004 – Reset Errors

0x000F – Save settings to EEPROM

0X00AA – Reset settings to defaults (command must be sent 3X in a row)

Example: To save settings to EEPROM

	Message ID	Length	Data Fields					
SEND	0x3FA	0x03	0x10	0x00	0x0F			
RECEIVE	(none)							

**0x11 – Command SET IDs – Write Only**

Used to change the default SSD CAN bus IDs to different ID numbers.

Example: To change the default CURRENT CAN ID from 0x03F1 (1009) to 0x04B0 (1200)

	Message ID	Length	Data Fields					
SEND	0x3FA	0x05	0x11	0x03	0xF1	0x04	0xB0	
RECEIVE	( none )							

**NOTE: No settings are saved until a save settings to EEPROM command is issued!  
Power cycling will restore previous settings. See command 0x10 0x000F.**

**SSD Interface Manual (continued)**

**0x12** – Command SETMODE – Read / Write

Used to change the sensor options.

Bit0 Invert Current – This will flip the Current and Coulomb signs if necessary.

Bit1 Autorange – Sensor will switch to high range if reading exceeds 85 % of standard range. It will switch back when reading drops to below 50 % of standard range. See A2D CONFIG for more info.

Bit2 Modbus Enable – Not used on CANbus version.

Bit3 Auto Reset Errors – Self clears errors once sent or read, the error will re-enable if it persists.

Bit4 Invert Voltage – Use for Highside Voltage Measurements.

Bit7 Send on Conversion – The sensor will send the latest data as soon as available per A2D CONFIG.

Bit8 Autosend – The sensor will send readings at the Read Delay timer interval unless Bit7 is enabled.

Bit9 to Bit15 – Enable the readings to be automatically sent. Otherwise read them manually.

SETMODE Configuration Bytes															
HEXCODE:															
Check boxes below to calculate HEX value															
15	14	13	12	11	10	9	8	7	6	5	4	3	2	1	0
1 = Send Errors/Alerts	1 = Send Energy Cnt	1 = Send Power	1 = Send Coulomb Cnt	1 = Send Vbus	1 = Send Temperature	1 = Send Current	1 = Autosend	1 = Send on Conversion	N/A	N/A	1 = Invert Voltage	1 = Auto Reset Errors/Alerts	Reserved	1 = Autorange	1 = Invert Current

**NOTE: No settings are saved until a save settings to EEPROM command is issued!  
Power cycling will restore previous settings. See command 0x10 0x000F.**

**SSD Interface Manual (continued)**

**0x12** (Continued) - Command SETMODE - Read / Write

SETMODE default is: 0x0002.

Example: To enable Autosend, Send Current, Send Errors, Auto Reset Errors (0x8308)

**Write Message**

	Message ID	Length	Data Fields					
SEND	0x3FA	0x03	0x12	0x83	0x08			
RECEIVE	(none)							

**Read Message**

	Message ID	Length	Data Fields					
SEND	0x3FB	0x01	0x12					
RECEIVE	0x3FC	0x03	0x12	0x83	0x08			

**NOTE: No settings are saved until a save settings to EEPROM command is issued!  
Power cycling will restore previous settings. See command 0x10 0x000F.**

**SSD Interface Manual (continued)**

**0x14 – Command BAUD RATE – Read / Write**

Used to set the SSD CAN bus Baud Rate. Values other than the following are ignored.

HEX Value	Baud Rate (kbit/s)
0x0009	125
0x000A	250
0x000B	500
0x000C	1000

Notes: Baud rate is changed immediately so you may get an error after change. Connect using new baud rate and use Command RESET MODE (0x10 0x000F) to save current settings to EEPROM. If unable to connect, reboot to restore the previous setting. BAUD RATE is defaulted to: 0x000B (500 kb/s).

Example: To set Baud Rate to 250 kbps

**Write Message**

	Message ID	Length	Data Fields					
SEND	0x3FA	0x03	0x14	0x00	0x0A			
RECEIVE	(none)							

**Read Message**

	Message ID	Length	Data Fields					
SEND	0x3FB	0x01	0x14					
RECEIVE	0x3FC	0x03	0x14	0x00	0x0A			

**NOTE: No settings are saved until a save settings to EEPROM command is issued!  
Power cycling will restore previous settings. See command 0x10 0x000F.**

**SSD Interface Manual (continued)**

**0x16 – Command SET READING DELAY - Read / Write**

Used to set the delay between readings automatically sent to the CANbus. Autosend must be enabled (see SETMODE bit8). Note: If the Conversion Time is greater than the reading delay, the sensor will send the same value until the next set of readings is available. For readings faster than 5 ms use SETMODE Bit7 Send on Conversion. This will send the data as soon as it's available.

Delay value from 5 to 60000 milli-seconds. READING DELAY default is: 0x03E8 (1 s).

Example: To set delay to 1 second between readings, 1 s = 1000 = 0x03E8

Delay (ms)

HEX Value

**CONVERT**

**Write Message**

	Message ID	Length	Data Fields					
SEND	0x3FA	0x03	0x16	0x03	0xE8			
RECEIVE	(none)							

**Read Message**

	Message ID	Length	Data Fields					
SEND	0x3FB	0x01	0x16					
RECEIVE	0x3FC	0x03	0x16	0x03	0xE8			

**NOTE: No settings are saved until a save settings to EEPROM command is issued!  
Power cycling will restore previous settings. See command 0x10 0x00F.**

SSD Interface Manual (continued)

0x17 – Command A2D CONFIG – Read / Write

A2D Configuration Register																
HEXCODE:																
Check boxes below to calculate HEX value																
N/A	Bus Voltage MAX Voltage			N/A	High Range MAX Current			N/A	Normal Range MAX Current			Reading Interval				Time (ms)
15	14	13	12	11	10	9	8	7	6	5	4	3	2	1	0	
	0	0	0		0	0	0		0	0	0	0	0	0	0	0.9
	1200 VDC				40X Nominal				40X Nominal			0	0	0	1	1.6
	0	0	1		0	0	1		0	0	1	0	0	1	0	3.2
	600 VDC				20X Nominal				20X Nominal			0	0	1	1	4.8
	0	1	0		0	1	0		0	1	0	0	1	0	0	6.4
	300 VDC				10X Nominal				10X Nominal			0	1	0	1	7.2
	0	1	1		0	1	1		0	1	1	0	1	1	0	9
	150 VDC				5X Nominal				5X Nominal			0	1	1	1	13
	1	0	0		1	0	0		1	0	0	1	0	0	0	26
	75 VDC				2.5X Nominal				2.5X Nominal			1	0	0	1	51
	1	0	1		1	0	1		1	0	1	1	0	1	0	102
	37.5 VDC				1.25X Nominal				1.25X Nominal			1	0	1	1	205
	1	1	0		1	1	0		1	1	0	1	1	0	0	410
	18.7 VDC				0.63X Nominal				0.63X Nominal			1	1	0	1	820
	1	1	1		1	1	1		1	1	1	1	1	1	0	1640
	9.37 VDC				0.31X Nominal				0.31X Nominal			1	1	1	1	3280

**NOTE: No settings are saved until a save settings to EEPROM command is issued!  
Power cycling will restore previous settings. See command 0x10 0x00F.**

Specifications are subject to change without notice.

Users should verify actual device performance in their specific applications.

The products described herein and this document are subject to specific legal disclaimers as set forth on the last page of this document, and at [www.bourns.com/docs/legal/disclaimer.pdf](http://www.bourns.com/docs/legal/disclaimer.pdf).

**SSD Interface Manual (continued)**

**0x17 (Continued) – Command A2D CONFIG – Read / Write**

Set the bits required for the application.

Notes:

High Range must be greater than or equal to the Normal Range. If SETMODE Bit1 (Autorange) is not set High Range will be ignored. If it is set, the sensor will automatically switch between the two ranges specified when necessary.

Reading intervals 13 ms and below utilize hardware averaging, 26 ms and above start using software averaging with a 13 ms hardware interval time. If it is necessary to capture and report fast current spikes, use fast reading intervals otherwise they will be averaged out.

Set the Vbus MAX voltage to the highest peak voltage expected. If using the sensor on the highside with voltage measuring, use 300 VDC range or lower.

A2D CONFIG default is: 0x035D.

Example: Vbus Max Voltage 1200 VDC, High Range 5X Nominal, Normal Range 1.25X Nominal, Reading Interval 820 ms (0x035D)

**Write Message**

	Message ID	Length	Data Fields					
SEND	0x3FA	0x03	0x17	0x03	0x5D			
RECEIVE	(none)							

**Read Message**

	Message ID	Length	Data Fields					
SEND	0x3FB	0x01	0x17					
RECEIVE	0x3FC	0x03	0x17	0x03	0x5D			

**NOTE: No settings are saved until a save settings to EEPROM command is issued!  
Power cycling will restore previous settings. See command 0x10 0x00F.**

**SSD Interface Manual (continued)**

**0x18 – Command CURRENT UNDER LIMIT – Read / Write**

Used to configure the optional lower limit for current readings. Currents below this value will cause an error that can be read with the 0x07 GET ERRORS command if errors aren't automatically sent. A zero value disables this alert, non-zero values enable alert.

Value is a signed Int16 in amps. Default CURRENT UNDER LIMIT: 0x0000 (Disabled).

Example: Set the lower limit to 25 amps (0x0019)

Amps

HEX Value

**CONVERT**

**Write Message**

	Message ID	Length	Data Fields					
SEND	0x3FA	0x03	0x18	0x00	0x19			
RECEIVE	(none)							

**Read Message**

	Message ID	Length	Data Fields					
SEND	0x3FB	0x01	0x18					
RECEIVE	0x3FC	0x03	0x18	0x00	0x19			

**NOTE: No settings are saved until a save settings to EEPROM command is issued!  
Power cycling will restore previous settings. See command 0x10 0x00F.**

**SSD Interface Manual (continued)**

**0x19 – Command CURRENT OVER LIMIT – Read / Write**

Used to configure the optional upper limit for current readings. Currents above this value will cause an error that can be read with the 0x07 GET ERRORS command if errors aren't automatically sent. A zero value disables this alert, non-zero values enable alert.

Value is a signed Int16 in amps. Default CURRENT OVER LIMIT: 0x0000 (Disabled).

Example: Set the upper limit to 620 amps (0x026C)

Amps

HEX Value

**CONVERT**

**Write Message**

	Message ID	Length	Data Fields					
SEND	0x3FA	0x03	0x19	0x02	0x6C			
RECEIVE	(none)							

**Read Message**

	Message ID	Length	Data Fields					
SEND	0x3FB	0x01	0x19					
RECEIVE	0x3FC	0x03	0x19	0x02	0x6C			

**NOTE: No settings are saved until a save settings to EEPROM command is issued!  
Power cycling will restore previous settings. See command 0x10 0x000F.**

**SSD Interface Manual (continued)**

**0x1A – Command TEMP OVER LIMIT – Read / Write**

Used to configure the temperature limit for the error. Temperatures above this value will cause an error that can be read with the 0x07 GET ERRORS command if errors aren't automatically sent.

Value is an unsigned Int16 in centigrade. Default TEMP OVER LIMIT: 125 °C (0x007D, Cannot Disable)

Valid Range: 0 °C to +125 °C (MAX)

Example: Set the upper limit to 90 °C (0x005A)

Temp. (°C)

HEX Value

**CONVERT**

**Write Message**

	Message ID	Length	Data Fields					
SEND	0x3FA	0x03	0x1A	0x02	0x5A			
RECEIVE	(none)							

**Read Message**

	Message ID	Length	Data Fields					
SEND	0x3FB	0x01	0x1A					
RECEIVE	0x3FC	0x03	0x1A	0x00	0x5A			

**NOTE: No settings are saved until a save settings to EEPROM command is issued!  
Power cycling will restore previous settings. See command 0x10 0x00F.**

**SSD Interface Manual (continued)**

**0x1B – Command VBUS UNDER LIMIT – Read / Write**

Used to configure the optional lower limit for the bus voltage readings. Voltages below this value will cause an error that can be read with the 0x07 GET ERRORS command if errors aren't automatically sent. A zero value disables this alert, non-zero values enable alert.

Value is a signed Int16 in volts. Default VBUS UNDER LIMIT: 0x0000 (Disabled).

Example: Set the lower limit to 29 Volts (0x001D)

Volts

HEX Value

**CONVERT**

**Write Message**

	Message ID	Length	Data Fields					
SEND	0x3FA	0x03	0x1B	0x00	0x1D			
RECEIVE	(none)							

**Read Message**

	Message ID	Length	Data Fields					
SEND	0x3FB	0x01	0x1B					
RECEIVE	0x3FC	0x03	0x1B	0x00	0x1D			

**NOTE: No settings are saved until a save settings to EEPROM command is issued!  
Power cycling will restore previous settings. See command 0x10 0x000F.**

**SSD Interface Manual (continued)**

**0x1C – Command VBUS OVER LIMIT - Read / Write**

Used to configure the optional upper limit for bus voltage readings. Voltages above this value will cause an error that can be read with the 0x07 GET ERRORS command if errors aren't automatically sent. A zero value disables this alert, non-zero values enable alert.

Value is a signed Int16 in Volts. Default VBUS OVER LIMIT: 0x0000 (Disabled).

Example: Set the upper limit to 70 Volts (0x0046)

Volts

HEX Value

**CONVERT**

**Write Message**

	Message ID	Length	Data Fields					
SEND	0x3FA	0x03	0x1C	0x00	0x46			
RECEIVE	(none)							

**Read Message**

	Message ID	Length	Data Fields					
SEND	0x3FB	0x01	0x1C					
RECEIVE	0x3FC	0x03	0x1C	0x00	0x46			

**NOTE: No settings are saved until a save settings to EEPROM command is issued!  
Power cycling will restore previous settings. See command 0x10 0x000F.**

**SSD Interface Manual (continued)**

**0x1D – Command POWER OVER LIMIT – Read / Write**

Used to configure the optional upper limit for power readings. Power above this value will cause an error that can be read with the 0x07 GET ERRORS command if errors aren't automatically sent. A zero value disables this alert, non-zero values enable alert.

Value is an unsigned Int32 in Watts. Default POWER OVER LIMIT: 0x00000000 (Disabled).

Example: Set the upper limit to 22000 Watts (0x000055F0)

Power (W)

HEX Value

**CONVERT**

**Write Message**

	Message ID	Length	Data Fields					
SEND	0x3FA	0x05	0x1D	0x00	0x00	0x55	0xF0	
RECEIVE	(none)							

**Read Message**

	Message ID	Length	Data Fields					
SEND	0x3FB	0x01	0x1D					
RECEIVE	0x3FC	0x05	0x1D	0x00	0x00	0x55	0xF0	

**NOTE: No settings are saved until a save settings to EEPROM command is issued!  
Power cycling will restore previous settings. See command 0x10 0x000F.**

**SSD Interface Manual (continued)**

**0x1E – Command SHUNT NANO-OHMS - Read / Write**

Used to override the resistance of the Model SSD Series from the factory calibration. This is typically not necessary and the correct equipment is essential to properly set it. Value can be reset back to factory defaults.

Value is an Int32

Example: To set SHUNT NANO-OHMS to 300156 (0x0004947C) nano-ohms

Nano-Ohms

HEX Value

**CONVERT**

**Write Message**

	Message ID	Length	Data Fields					
SEND	0x3FA	0x05	0x1E	0x00	0x04	0x94	0x7C	
RECEIVE	(none)							

**Read Message**

	Message ID	Length	Data Fields					
SEND	0x3FB	0x01	0x1E					
RECEIVE	0x3FC	0x05	0x1E	0x00	0x04	0x94	0x7C	

**NOTE: No settings are saved until a save settings to EEPROM command is issued!  
Power cycling will restore previous settings. See command 0x10 0x00F.**

**SSD Interface Manual (continued)**

**0x21 – Command CURRENT ZERO OFFSET – Read / Write**

Used to override the sensor zero offset current. Value can be reset back to factory defaults.

Value is a signed Int16.

Example: To set CURRENT OFFSET to +8 (0x0008) mA.

Offset (mA)

HEX Value

**CONVERT**

**Write Message**

	Message ID	Length	Data Fields					
SEND	0x3FA	0x03	0x21	0x00	0x08			
RECEIVE	(none)							

**Read Message**

	Message ID	Length	Data Fields					
SEND	0x3FB	0x01	0x21					
RECEIVE	0x3FC	0x03	0x21	0x00	0x08			

**NOTE: No settings are saved until a save settings to EEPROM command is issued!  
Power cycling will restore previous settings. See command 0x10 0x000F.**

**SSD Interface Manual (continued)**

**0x22 – Command VBUS FACTOR – Read / Write**

Used to adjust the Bus Voltage reading from the factory calibration. This is typically not necessary and the correct equipment is essential to properly set it. See reset command to set the value back to factory default. Voltage is calibrated at 25 °C. Power and Energy values are scaled appropriately.

Value is an Int16. Value is divided by 10000 in firmware to create the factor.

Example: To set VBUS FACTOR to 10023 (0x2727)

Vbus Factor

HEX Value

**CONVERT**

**Write Message**

	Message ID	Length	Data Fields					
SEND	0x3FA	0x03	0x22	0x27	0x27			
RECEIVE	(none)							

**Read Message**

	Message ID	Length	Data Fields					
SEND	0x3FB	0x01	0x22					
RECEIVE	0x3FC	0x03	0x22	0x27	0x27			

**NOTE: No settings are saved until a save settings to EEPROM command is issued!  
Power cycling will restore previous settings. See command 0x10 0x00F.**

**SSD Interface Manual (continued)**

**0x23 – Command VBUS ZERO OFFSET – Read / Write**

Used to override the bus voltage zero offset. Value can be reset back to factory defaults.

Value is a signed Int16.

Example: To set VBUS OFFSET to -6 (0xFFF9) mV.

Vbus Offset (mV)

HEX Value

**CONVERT**

**Write Message**

	Message ID	Length	Data Fields					
SEND	0x3FA	0x03	0x23	0xFF	0xF9			
RECEIVE	(none)							

**Read Message**

	Message ID	Length	Data Fields					
SEND	0x3FB	0x01	0x23					
RECEIVE	0x3FC	0x03	0x23	0xFF	0xF9			

**NOTE: No settings are saved until a save settings to EEPROM command is issued!  
Power cycling will restore previous settings. See command 0x10 0x00F.**

**SSD Interface Manual (continued)**

**0x24 – Command TEMP OFFSET – Read / Write**

Used to adjust the Temperature reading from the factory calibration. This is typically not necessary and the correct equipment is essential to properly set it. See reset command to set the value back to factory default. Value is an Signed Int16.

Example: To set TEMP OFFSET to -2.2 °C send -22 (0xFFEA)

Temp. Offset (0.1 °C)

HEX Value

**CONVERT**

**Write Message**

	Message ID	Length	Data Fields					
SEND	0x3FA	0x03	0x24	0xFF	0xEA			
RECEIVE	(none)							

**Read Message**

	Message ID	Length	Data Fields					
SEND	0x3FB	0x01	0x24					
RECEIVE	0x3FC	0x03	0x24	0xFF	0xEA			

**NOTE: No settings are saved until a save settings to EEPROM command is issued!  
Power cycling will restore previous settings. See command 0x10 0x00F.**

**SSD Interface Manual (continued)**

**0x25** – Command GET T0 TEMPERATURE COMPENSATION – Read Only

**0x26** – Command GET T1 TEMPERATURE COMPENSATION – Read Only

**0x27** – Command GET T2 TEMPERATURE COMPENSATION – Read Only

Used to get the factory calibrated settings for the temperature compensation constants.

T0 - unsigned int16

T1 - signed int32

T2 - signed int32

Example: The following shows T1 compensation constant of FFBE E23D (-4267459)

**Read Message**

	Message ID	Length	Data Fields					
SEND	0x3FB	0x01	0x26					
RECEIVE	0x3FC	0x05	0x26	0xFF	0xBE	0xE2	0x3D	

**NOTE: No settings are saved until a save settings to EEPROM command is issued!  
Power cycling will restore previous settings. See command 0x10 0x00F.**

**SSD Interface Manual (continued)**

**0x28** – Command GET RESET CAUSES – Read Only

Used to get the reasons for the last four SSD sensor restarts.

Example: The following shows abnormal restarts (0x0140)

**Read Message**

	Message ID	Length	Data Fields					
SEND	0x3FB	0x01	0x28					
RECEIVE	0x3FC	0x03	0x28	0x01	0x40			

**0x0140**

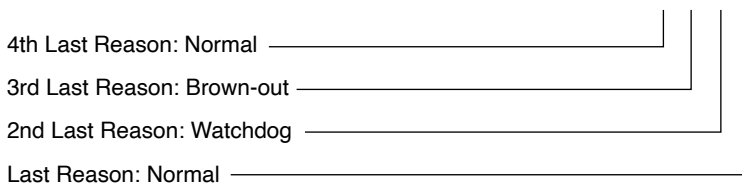

**Reason Codes**

- 0 - Normal Power-on Reset
- 1 - Brown-out Reset
- 4 - Watchdog Timer Time-Out Reset
- 6 - Software RESET Instruction
- 7 - Master Clear Pin Reset
- 9 - Configuration Mismatch Reset
- E - Illegal Condition Device Reset
  - Illegal Opcode Reset
  - Uninitialized W Register Reset
  - Security Reset
- F - Trap Conflict Reset

**SSD Interface Manual (continued)**

**0x30** – Command GET FIRMWARE VERSION – Read Only

Used to get the SSD firmware version. Data Returned: Version (byte) and subversion (byte)

Example: The following shows version (v1.2)

**Read Message**

	Message ID	Length	Data Fields					
SEND	0x3FB	0x01	0x30					
RECEIVE	0x3FC	0x03	0x30	0x01	0x02			

**0x31** – Command GET SERIAL NUMBER – Read Only

Used to get the SSD serial number.

Example: The following shows SN:00012345 (0x3039)

**Read Message**

	Message ID	Length	Data Fields					
SEND	0x3FB	0x01	0x31					
RECEIVE	0x3FC	0x05	0x31	0x00	0x00	0x30	0x39	

**NOTE: No settings are saved until a save settings to EEPROM command is issued!  
Power cycling will restore previous settings. See command 0x10 0x000F.**

**SSD Interface Manual (continued)**

Firmware Revisions-

v2.10

Added Invert Bus Voltage bit to SETMODE command for highside sensor mounting.

v2.11

Updated internal ADC settings to reduce noise. This reduces some of the fixed ADC reading intervals.  
Fixed reading Coulombs and Energy manually after changing CAN IDs.

v2.12

Bus Voltage is now signed int32,  $\pm 1200$  VDC.  
Current and Voltage Under and Over limits are now signed int16.  
Can now write Coulomb value to sensor and the sensor will count from there.  
Get all enabled readings changed from register 0x08 to 0x00.

**BOURNS®**

**Americas:** Tel: +1 951-781-5500 • Email: [americus@bourns.com](mailto:americus@bourns.com)

**Mexico:** Tel: +52-614-478-0400 • Email: [mexicus@bourns.com](mailto:mexicus@bourns.com)

**Asia:** Tel: +886-2-2562-4117 • Email: [asiacus@bourns.com](mailto:asiacus@bourns.com)

**EMEA:** Tel: +36 88 885 877 • Email: [eurocus@bourns.com](mailto:eurocus@bourns.com)

[www.bourns.com](http://www.bourns.com)

REV. 11/25

Specifications are subject to change without notice.

Users should verify actual device performance in their specific applications.

The products described herein and this document are subject to specific legal disclaimers as set forth on the last page of this document, and at [www.bourns.com/docs/legal/disclaimer.pdf](http://www.bourns.com/docs/legal/disclaimer.pdf).

“Bourns” is a registered trademark of Bourns, Inc. in the United States and other countries.

In April 2023, BE Services Company, Inc., a subsidiary of Bourns, Inc., purchased certain assets of Riedon, Inc., including its logo and trademarks and the right to continue to manufacture former Riedon™ products.

“Riedon” is a trademark of BE Services Company, Inc.