



Features

- Shielded construction
- Inductance range: 1.0 to 1000 μ H
- Heating current up to 11 A
- Dimensions: 12 x 12 x 10 mm
- AEC-Q200 compliant
- RoHS compliant* and halogen free**

Additional Information

Click these links for more information:



SRR1210A Series - Shielded Power Inductors

Electrical Specifications @ 25 °C

Bourns Part Number	Inductance @ 1 kHz / 0.25 V		Q Ref.	Q Test Freq. (MHz)	SRF (MHz) Typ.	DCR (Ω) Max.	I rms (A)	I sat (A)	***K-Factor
	L (μ H)	Tol. (%)							
SRR1210A-1R0Y	1.0	± 30	10	7.96	85	0.006	11.0	16.5	86
SRR1210A-1R8Y	1.8	± 30	10	7.96	56	0.075	10.2	13.2	67
SRR1210A-2R2Y	2.2	± 30	10	7.96	54	0.09	9.5	12.2	55
SRR1210A-3R3Y	3.3	± 30	15	7.96	44	0.01	9.0	10.5	46
SRR1210A-4R7Y	4.7	± 30	8	7.96	35	0.012	8.5	9.6	40
SRR1210A-5R6Y	5.6	± 30	12	7.96	28	0.0135	8.0	8.5	35
SRR1210A-6R8Y	6.8	± 30	12	7.96	20	0.015	7.85	8.3	32
SRR1210A-8R2Y	8.2	± 30	11	7.96	16	0.017	7.25	7.55	29
SRR1210A-100M	10	± 20	16	2.52	12	0.018	6.5	6.5	26
SRR1210A-120M	12	± 20	14	2.52	18	0.022	6.3	6.1	24
SRR1210A-150M	15	± 20	16	2.52	10.5	0.032	5.8	5.3	21
SRR1210A-180M	18	± 20	13	2.52	8	0.035	5.5	5.1	19
SRR1210A-220M	22	± 20	16	2.52	8	0.038	5.2	4.5	17
SRR1210A-270M	27	± 20	16	2.52	6.5	0.04	5.0	4.2	15
SRR1210A-330M	33	± 20	16	2.52	6.5	0.052	4.4	3.7	14
SRR1210A-390M	39	± 20	16	2.52	4.5	0.066	4.2	3.5	13
SRR1210A-470M	47	± 20	16	2.52	4.5	0.072	3.8	3.1	12
SRR1210A-560M	56	± 20	8	2.52	4	0.09	3.4	2.9	11
SRR1210A-680M	68	± 20	12	2.52	3.8	0.102	3.0	2.7	10
SRR1210A-820M	82	± 20	15	2.52	3.5	0.112	2.8	2.5	9
SRR1210A-101M	100	± 20	16	0.796	3	0.135	2.5	2.2	8
SRR1210A-121M	120	± 20	13	0.796	2.6	0.17	2.3	1.9	7
SRR1210A-151M	150	± 20	12	0.796	2.2	0.19	2.2	1.8	7
SRR1210A-181M	180	± 20	14	0.796	1.8	0.25	1.9	1.6	6
SRR1210A-221M	220	± 20	15	0.796	1.8	0.315	1.7	1.5	5
SRR1210A-271M	270	± 20	16	0.796	1.8	0.41	1.5	1.3	5
SRR1210A-331M	330	± 20	14	0.796	1.8	0.45	1.4	1.2	4
SRR1210A-391M	390	± 20	16	0.796	1.3	0.6	1.3	1.1	4
SRR1210A-471M	470	± 20	12	0.796	0.85	0.82	1.2	1.0	4
SRR1210A-561M	560	± 20	12	0.796	0.85	0.9	1.1	0.95	3
SRR1210A-681M	680	± 20	11	0.796	0.85	1.2	1.0	0.85	3
SRR1210A-821M	820	± 20	6	0.796	0.85	1.32	0.85	0.75	3
SRR1210A-102M	1000	± 20	22	0.796	0.85	1.65	0.75	0.7	3

***K-Factor: To calculate core flux density, B_p -p (gauss) = $K \times L(\mu H) \times \Delta I$ (peak-to-peak ripple current, A), determine core loss from *Core Loss vs. Flux Density* plot.

How to Order

SRR1210A - 100M

Model _____
Value Code (see table) _____

Electrical Schematic

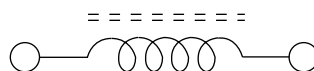

WARNING Cancer and Reproductive Harm www.P65Warnings.ca.gov

* RoHS Directive 2015/863, Mar 31, 2015 and Annex.

** Bourns considers a product to be "halogen free" if (a) the Bromine (Br) content is 900 ppm or less; (b) the Chlorine (Cl) content is 900 ppm or less; and (c) the total Bromine (Br) and Chlorine (Cl) content is 1500 ppm or less.

Specifications are subject to change without notice. Users should verify actual device performance in their specific applications. The products described herein and this document are subject to specific legal disclaimers as set forth on the last page of this document, and at www.bourns.com/docs/legal/disclaimer.pdf.

General Specifications

Operating Temperature -40 °C to +125 °C
(Temperature rise included)
Storage Temperature -40 °C to +125 °C
Temperature Rise 40 °C typ. at rated I_{rms}
Inductance drop 20 % at I_{sat}

Materials

Core Ferrite
Wire Enameled copper
Terminal Finish Sn
Packaging 250 pcs. per reel

Product Dimensions

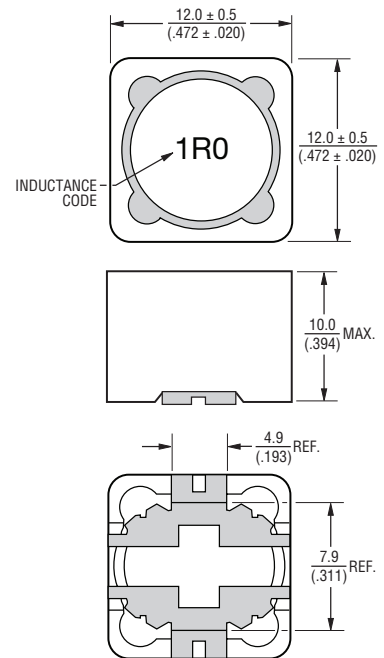

Recommended Layout

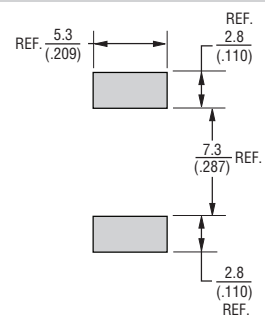

DIMENSIONS: $\frac{\text{MM}}{\text{(INCHES)}}$

SRR1210A Series - Shielded Power Inductors



Inductance vs. IDC

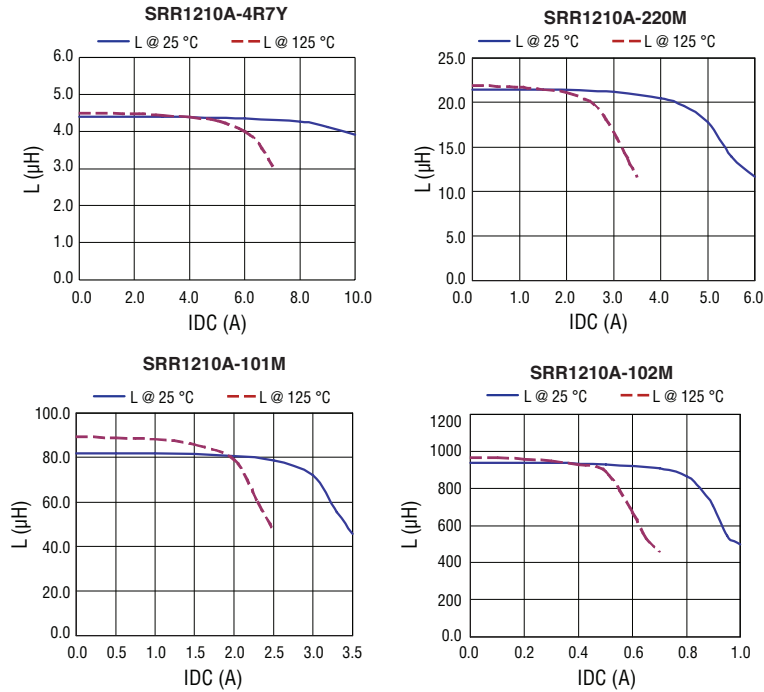

Temperature Rise vs. IDC

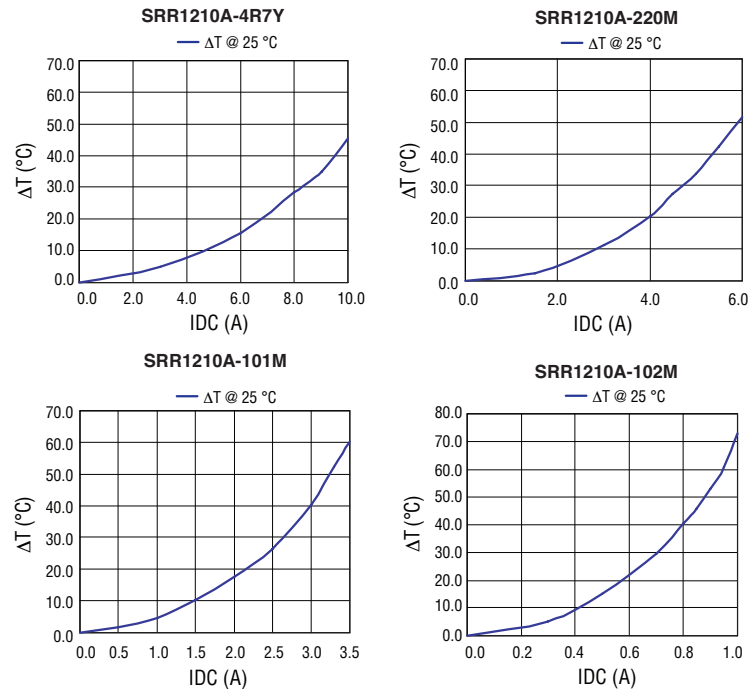

Specifications are subject to change without notice.

Users should verify actual device performance in their specific applications.

The products described herein and this document are subject to specific legal disclaimers as set forth on the last page of this document, and at www.bourns.com/docs/legal/disclaimer.pdf.

SRR1210A Series - Shielded Power Inductors



Soldering Profile

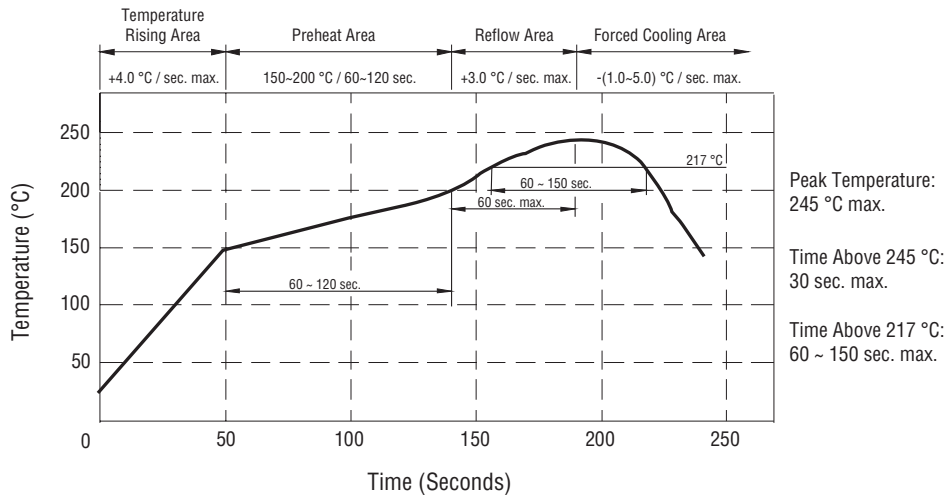

Core Loss vs. Flux Density

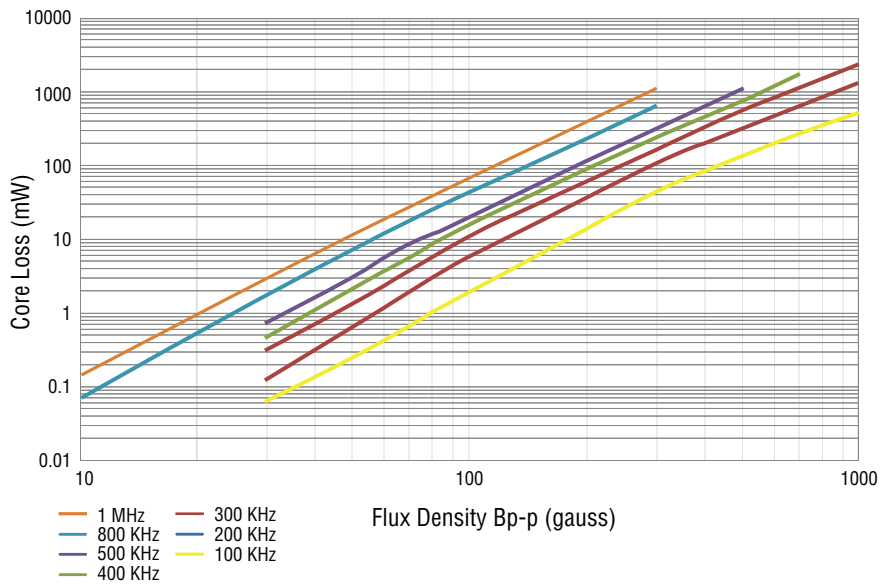

Specifications are subject to change without notice. Users should verify actual device performance in their specific applications. The products described herein and this document are subject to specific legal disclaimers as set forth on the last page of this document, and at www.bourns.com/docs/legal/disclaimer.pdf.

SRR1210A Series - Shielded Power Inductors

BOURNS®

Packaging Specifications

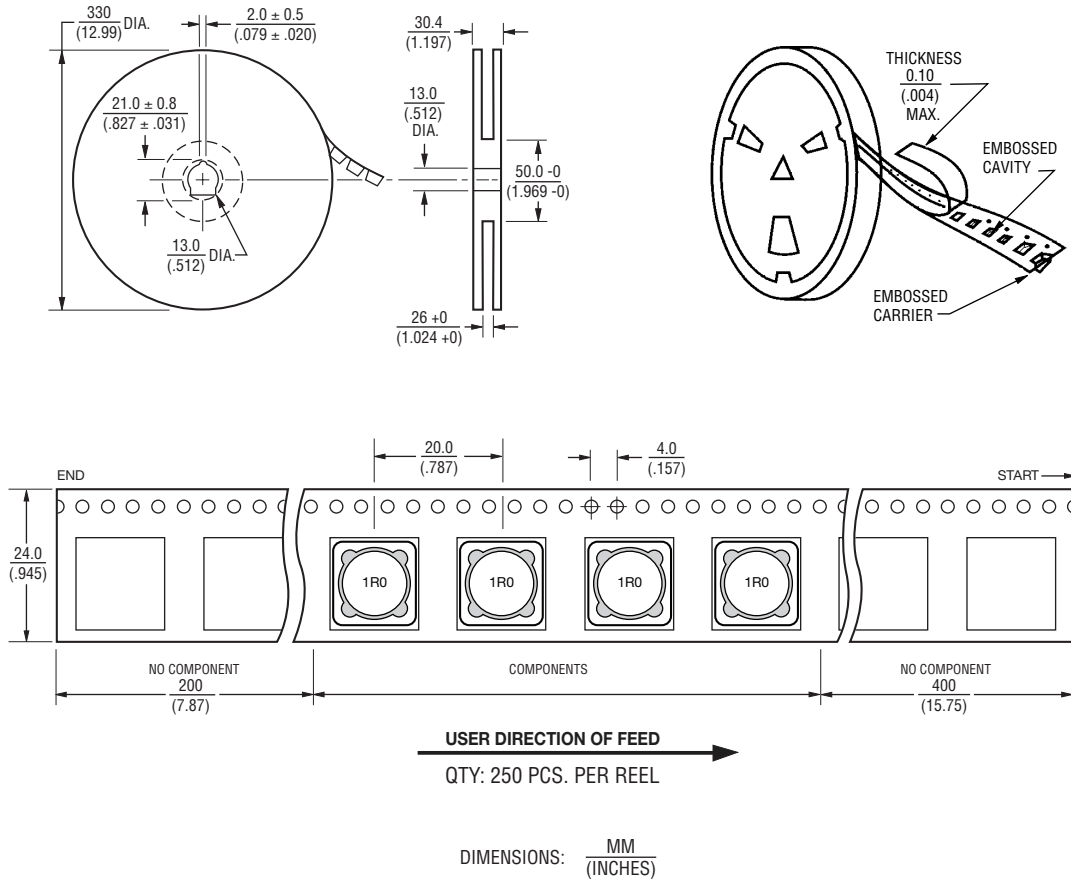

BOURNS®

Asia-Pacific: Tel: +886-2 2562-4117 • Email: asiacus@bourns.com

Europe: Tel: +36 88 885 877 • Email: eurocus@bourns.com

Mexico: Tel: +52 614 478 0400 • Email: mexicus@bourns.com

The Americas: Tel: +1-951 781-5500 • Email: americus@bourns.com

www.bourns.com

REV. 09/24

Specifications are subject to change without notice.

Users should verify actual device performance in their specific applications.

The products described herein and this document are subject to specific legal disclaimers as set forth on the last page of this document, and at www.bourns.com/docs/legal/disclaimer.pdf.