

Features

- Push switch option standard
- Compact, rugged design
- High reliability
- Metal bushing/shaft
- Surface mount version

Applications

Level control, tuning and timer settings in:

- Audio-visual equipment
- Consumer electric appliances
- Radios
- Musical instrumentation
- Communications equipment

PEC11S Series - 12 mm SMD Incremental Encoder

Electrical Characteristics

| | |
|---------------------------------|-----------------------|
| Output | 2-bit quadrature code |
| Closed Circuit Resistance | 3 ohms maximum |
| Contact Rating | 10 mA @ 5 VDC |
| Insulation Resistance | 100 megohms @ 250 VDC |
| Dielectric Withstanding Voltage | |
| Sea Level | 300 VAC minimum |
| Electrical Travel | Continuous |
| Contact Bounce (15 RPM) | 2.0 ms maximum |
| RPM (Operating) | 60 maximum |

Environmental Characteristics

| | |
|-----------------------------------|--------------------------------------|
| Operating Temperature Range | -40 °C to +70 °C (-40 °F to +158 °F) |
| Storage Temperature Range | -40 °C to +85 °C (-40 °F to +185 °F) |
| Operating Humidity | 25 % to 85 % R.H. |
| Rotational Life | 15,000 cycles minimum |
| Switch Life | 20,000 cycles minimum |
| IP Rating | IP 40 |
| Moisture Sensitivity Level | 1 |
| ESD Classification (HBM) | N/A |

Mechanical Characteristics

| | |
|--------------------------------|---|
| Mechanical Angle | 360 ° continuous |
| Detent Torque | 100 ±70 gf.cm (1.36 ±0.1 oz.-in.) |
| Shaft Push-Pull Strength | 10 kg max. |
| Weight | 5 gm (0.17 oz.) maximum |
| Terminals | Printed circuit board surface mount terminals |
| Soldering Condition | |
| Reflow Soldering | Sn95.5/Ag2.8/Cu0.7 solder with no-clean flux (see Solder Profiles for recommended time and temperature) |
| Hand Soldering | Not recommended |
| Hardware | No hardware supplied with this encoder |

Switch Characteristics

| | |
|-------------------------------------|--------------------------------|
| Switch Type | Contact Push ON Momentary SPST |
| Power Rating (Resistive Load) | 10 mA at 5 V DC |
| Switch Travel | |
| S (Standard) | 0.5 ± 0.3 mm |
| H (High) | 1.5 ± 0.5 mm |
| Switch Actuation Force | See How to Order |
| Contact Resistance | 100 mΩ max. |



Asia-Pacific: Tel: +886-2 2562-4117 • Email: asiacus@bourns.com

Europe: Tel: +36 88 885 877 • Email: eurocus@bourns.com

Mexico: Tel: +52 614 478 0400 • Email: mexicus@bourns.com

The Americas: Tel: +1-951 781-5500 • Email: americus@bourns.com

www.bourns.com

Additional Information

Click these links for more information:



[PRODUCT SELECTOR](#)



[TECHNICAL LIBRARY](#)



[INVENTORY](#)



[SAMPLES](#)



[CONTACT](#)



WARNING Cancer and Reproductive Harm - www.P65Warnings.ca.gov

*RoHS Directive 2015/863, Mar 31, 2015 and Annex.

Specifications are subject to change without notice.

Users should verify actual device performance in their specific applications.

The products described herein and this document are subject to specific legal disclaimers as set forth on the last page of this document, and at www.bourns.com/docs/legal/disclaimer.pdf.

The device characteristics and parameters in this data sheet can and do vary in different applications and actual device performance may vary over time.

PEC11S Series - 12 mm SMD Incremental Encoder

BOURNS®

Solder Profile

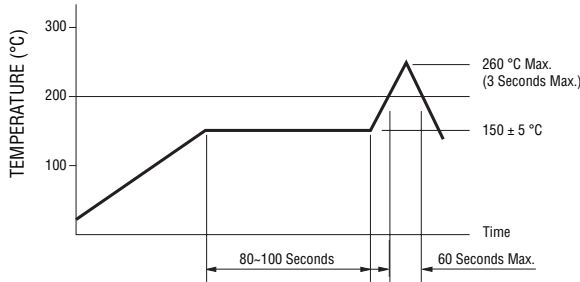

Processing Method: Reflow soldering with infrared heat or forced air convection (only once).

Notes:

1. No clean solder paste is recommended.
2. Aqueous wash is not recommended.
3. Use of water soluble soldering flux shall be avoided due to possible corrosion.
4. Multiple passes through the soldering process is not recommended.

Product Dimensions

Common Dimensions

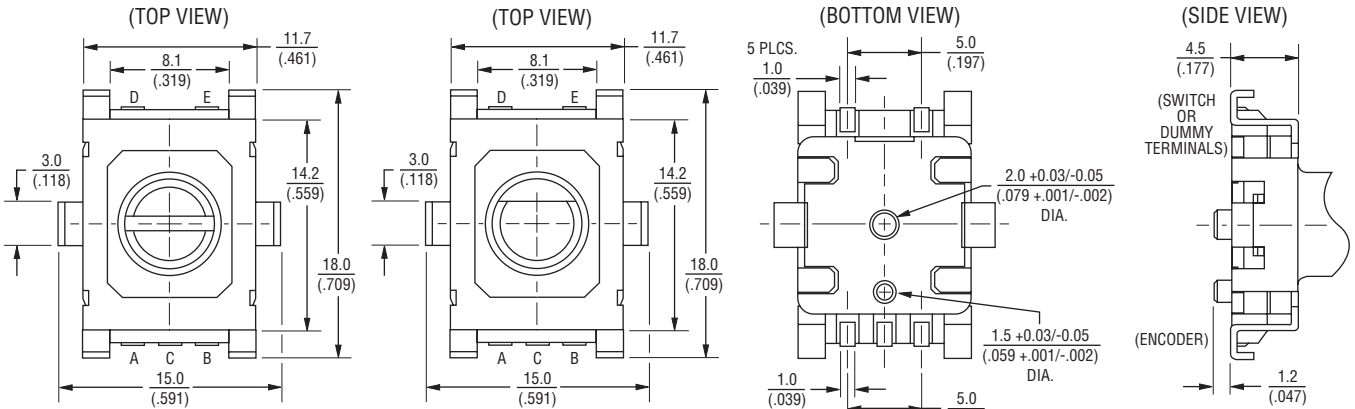

TOLERANCES (UNLESS OTHERWISE NOTED): ≤ 10 = ± 0.3
 $\leq (.394)$ = $\pm (.012)$

> 10 = ± 0.5
 $> (.394)$ = $\pm (.020)$

DIMENSIONS: $\frac{\text{MM}}{\text{(INCHES)}}$

Recommended PCB Layout

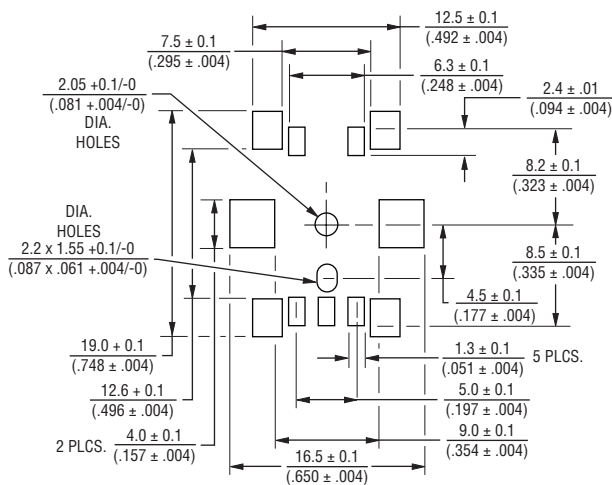

Suggested Filter Circuit

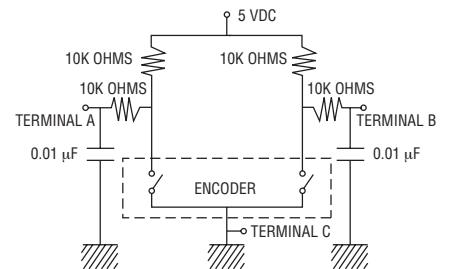

Specifications are subject to change without notice.

Users should verify actual device performance in their specific applications.

The products described herein and this document are subject to specific legal disclaimers as set forth on the last page of this document, and at www.bourns.com/docs/legal/disclaimer.pdf.

PEC11S Series - 12 mm SMD Incremental Encoder



Product Dimensions - Shaft Styles

PEC11S without Switch

KNURLED SHAFT

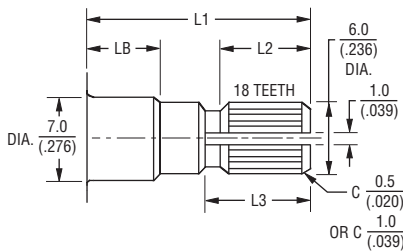

| L1 | LB | L2 | L3 |
|--------------|-------------|--------------|--------------|
| 15 (.591) | 5 (.197) | 7 (.279) | 8 (.315) |
| 20 (.787) | 7 (.276) | 10 (.394) | 11 (.433) |

DIMENSIONS: $\frac{\text{MM}}{\text{(INCHES)}}$

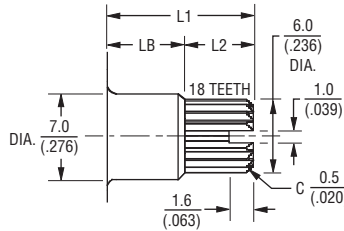

| L1 | LB | L2 |
|---------------|-------------|---------------|
| 9.5 (.374) | 5 (.197) | 4.5 (.177) |

FLATTED SHAFT

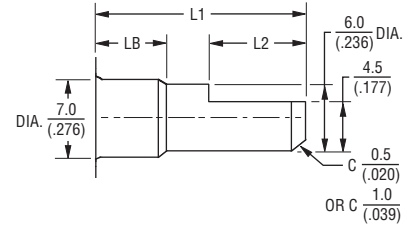

| L1 | LB | L2 |
|--------------|-------------|--------------|
| 15 (.591) | 5 (.197) | 7 (.276) |
| 20 (.787) | 7 (.276) | 12 (.472) |

PEC11S with 0.5 mm Switch Travel

KNURLED SHAFT

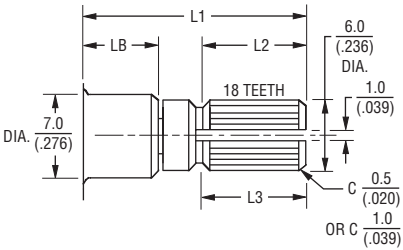

| L1 | LB | L2 | L3 |
|--------------|-------------|-------------|---------------|
| 15 (.591) | 5 (.197) | 7 (.279) | 7.5 (.295) |
| 20 (.787) | 7 (.276) | 9 (.354) | 10 (.394) |

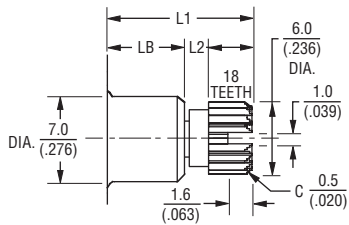

| L1 | LB | L2 |
|----------------|-------------|---------------|
| 9.5 (.374) | 5 (.197) | 2.7 (.106) |
| 13.5 (.531) | 5 (.197) | 6.7 (.264) |

FLATTED SHAFT

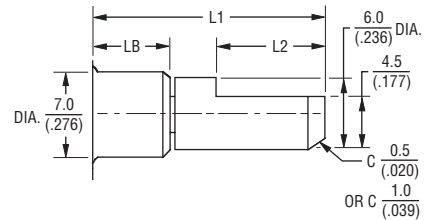

| L1 | LB | L2 |
|---------------|-------------|--------------|
| 9.5 (.374) | 5 (.197) | 3 (.118) |
| 15 (.591) | 5 (.197) | 7 (.276) |
| 20 (.787) | 7 (.276) | 10 (.394) |

PEC11S with 1.5 mm Switch Travel

KNURLED SHAFT

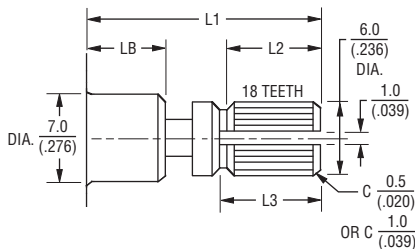

| L1 | LB | L2 | L3 |
|--------------|-------------|-------------|---------------|
| 15 (.591) | 5 (.197) | 6 (.236) | 6.5 (.256) |
| 20 (.787) | 7 (.276) | 8 (.315) | 9 (.354) |

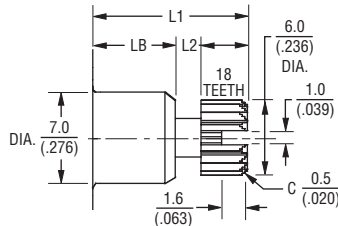

| L1 | LB | L2 |
|----------------|-------------|---------------|
| 9.5 (.374) | 5 (.197) | 2.9 (.114) |
| 13.5 (.531) | 5 (.197) | 6.9 (.272) |

FLATTED SHAFT

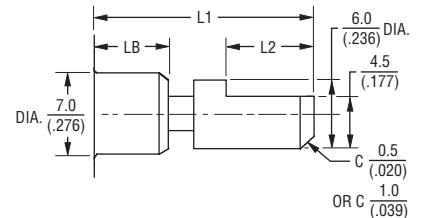

| L1 | LB | L2 |
|--------------|-------------|--------------|
| 15 (.591) | 5 (.197) | 7 (.276) |
| 20 (.787) | 7 (.276) | 10 (.394) |
| 25 (.985) | 7 (.275) | 12 (.473) |

Specifications are subject to change without notice. Users should verify actual device performance in their specific applications. The products described herein and this document are subject to specific legal disclaimers as set forth on the last page of this document, and at www.bourns.com/docs/legal/disclaimer.pdf.

PEC11S Series - 12 mm SMD Incremental Encoder



How To Order

PEC11S - 9 2 20 F - S 0015

- Model _____
- Terminal Configuration _____
9 = Surface Mount Gull-wing Style
- Detent Option _____
2 = 30 Detents
- Shaft Length (See Product Dimensions - Shaft Styles for Availability) _____
9 = 9.5 mm
13 = 13.5 mm
15 = 15.0 mm
20 = 20.0 mm
25 = 25.0 mm (Flat Shaft and H-Switch Configuration Only)
- Shaft Style _____
F = Flatted, Metal
K = Knurled, Metal
- Switch Configuration (SPST) _____
S = 350 ± 100 gf
H = 400 ± 200 gf
N = No Switch
- Resolution _____
0015 = 15 Pulses per 360 ° Rotation

Quadrature Output Table

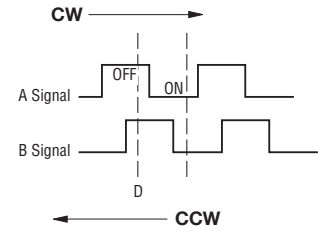

Switch Circuit

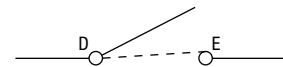

NOTE: D and E are dummy terminals on non-switch version.

Packaging

- Tray 60 pcs. per tray
- Outer Box 10 trays; 1200 pcs. per box

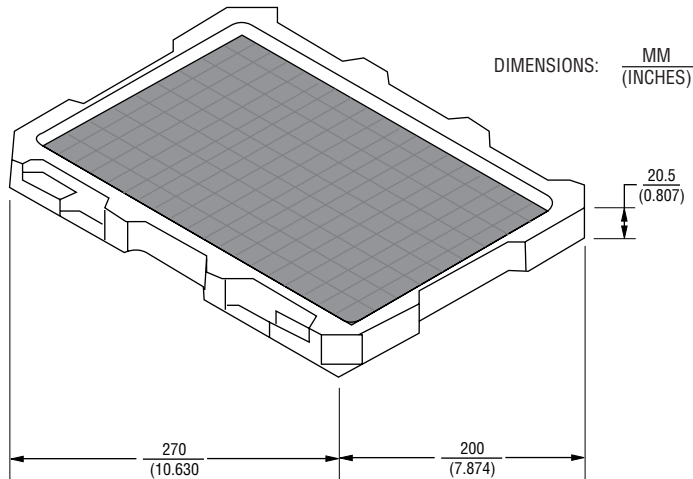

REV. 07/25

Specifications are subject to change without notice.
Users should verify actual device performance in their specific applications.
The products described herein and this document are subject to specific legal disclaimers as set forth on the last page of this document, and at www.bourns.com/docs/legal/disclaimer.pdf.

This legal disclaimer applies to purchasers and users of Bourns® products manufactured by or on behalf of Bourns, Inc. and its affiliates (collectively, "Bourns").

Unless otherwise expressly indicated in writing, Bourns® products and data sheets relating thereto are subject to change without notice. Users should check for and obtain the latest relevant information and verify that such information is current and complete before placing orders for Bourns® products.

The characteristics and parameters of a Bourns® product set forth in its data sheet are based on laboratory conditions, and statements regarding the suitability of products for certain "typical" applications are based on Bourns' knowledge of typical requirements in generic applications. Bourns assumes that "typical" applications include failsafe/backup features to address critical risks to users and are designed to allow rework of Bourns® product to avoid scrap of a device solely due to malfunctioning Bourns® product. The characteristics and parameters of a Bourns® product in a user application may vary from the data sheet characteristics and parameters due to (i) the combination of the Bourns® product with other components in the user's application, or (ii) the environment of the user application itself. The characteristics and parameters of a Bourns® product also can and do vary in different applications and actual performance may vary over time. Thus, users should always verify the actual performance of the Bourns® product in their specific devices and applications and make their own independent judgments regarding the suitability of Bourns® product and the amount of additional test margin to design into their device or application to compensate for differences between laboratory and real-world conditions.

Unless Bourns has explicitly designated an individual Bourns® product as meeting the requirements of a particular industry standard (e.g., IATF 16949) or a particular qualification (e.g., UL listed or recognized), Bourns is not responsible for any failure of an individual Bourns® product to meet the requirements of such industry standard or particular qualification even if such industry standard or qualification is a "state of art". Users of Bourns® products are responsible for ensuring compliance with safety-related requirements and standards applicable to their devices or applications.

Bourns® products are not recommended, authorized or intended for use in applications where failure or malfunction may result in personal injury, death, or severe property or environmental damage, such as without limitation nuclear, life-critical medical and certain automotive and aviation applications. Except as set forth in the bullet points below or unless expressly and specifically approved in writing on a case-by-case basis by an authorized Bourns' representative, use of any Bourns® products in such unauthorized high-risk applications is at the user's sole risk.

- Bourns considers implantable/invasive devices and devices/procedures designed as life-supporting or life-sustaining by the U.S. Food and Drug Administration or equivalent organizations outside of the United States as "life-critical" medical applications. Bourns expressly identifies those Bourns® standard products that are suitable for use in typical medical applications that are not life-critical in its publication entitled "Bourns Medical Grade Component Guide."
- Bourns expressly identifies those Bourns® standard products that are suitable for use in typical automotive applications associated with any Automate Safety Integrity Level (ASIL) in its publication entitled "Bourns Automotive Grade Component Guide." Bourns' designation of Bourns® product as compliant with the AEC-Q standard does not by itself mean that Bourns has approved such product for use in an automotive application.
- Bourns expressly identifies Bourns® standard products that are suitable for use in the typical aviation applications/systems requiring System Design Assurance Level (RTCA DO-254 DAL) of C, D or E in its publication entitled "Bourns Civilian Aerospace/Aviation Grade Component Guide." Bourns does not test its products for compliance with United States Federal Aviation Administration standards or any other generally equivalent governmental organization standard applicable to products designed or manufactured for use in aviation applications. Use of Bourns® standard components in aviation applications associated with RTCA DO-254 DAL A or B without proper approval noted above shall be at the user's sole risk.
- Bourns will review and authorize on a case-by-case basis the use of Bourns® standard products which are at least AEC-Q compliant in space-related civil applications (rockets, satellites) with a negotiated cross-waiver and indemnity agreement.

The use and level of testing applicable to Bourns® custom products shall be negotiated on a case-by-case basis by Bourns and the user for which such Bourns® custom products are specially designed. Absent a written agreement between Bourns and the user regarding the use and level of such testing, the above provisions applicable to Bourns® standard products shall also apply to such Bourns® custom products.

Use of Bourns® products or Bourns' technology in military/defense applications must be reviewed with Bourns for compliance with applicable export control laws and embargoes. Users shall not sell, transfer, export or re-export (which includes transfers within a country) any Bourns® products or technology or technical data for use in activities which involve the design, development, production, use or stockpiling of nuclear, chemical or biological weapons or missiles, nor shall they use Bourns® products or technology or technical data in any facility which engages in activities relating to such devices. Further, Bourns® products and Bourns' technology and technical data may not under any circumstance be exported or re-exported to countries subject to international sanctions or embargoes. Bourns® products and technology may not, without prior authorization from Bourns and/or the Government of a country where such product/technology is designed and/or manufactured, be resold, transferred, or re-exported (including within the same country) to any party not eligible to receive commodities, software, and technical data originating in such country.

To the maximum extent permitted by applicable law, Bourns disclaims (i) any and all liability for special, punitive, consequential, incidental or indirect damages or lost revenues or lost profits, and (ii) any and all implied warranties (those not based on parameters specified in Bourns' data sheets and/or specifications), including implied warranties of fitness for particular purpose, non-infringement and merchantability.

For your convenience, copies of this Legal Disclaimer Notice with German, Spanish, Japanese, Traditional Chinese and Simplified Chinese bilingual versions are available at:

Web Page: <https://www.bourns.com/legal/disclaimers-terms-and-policies>

PDF: <https://www.bourns.com/docs/Legal/disclaimer.pdf>