

Features

- Fast response time
- Wide temperature range
- High surge current rating
- Low capacitance and insertion loss
- Stable performance throughout life
- RoHS compliant*

Applications

- Industrial control panels / MCCs
- HVAC
- EV charging
- BESS / BMS interfaces
- PV inverter and combiner DC input

Sustainability

- Small size reduces material use
- Corrosion-resistant for longevity
- ISO 14001, low-impact energy
- Responsibly sourced and produced

Product Overview

Bourns' new and improved next-generation surface mount 2-electrode GDT surge protection devices have been designed using Bourns' proprietary, advanced computer simulation techniques and offer industry-leading maximum impulse voltage limiting specifications in a small, environmentally rugged surface mount package.

The performance delivered in the Bourns® Model GDT25H helps to significantly heighten protection against induced voltage transients such as lightning and AC induction. Plus, the enhanced level of protection with tighter voltage limiting provided during fast-rising events will reduce stress on downstream components compared to current GDT designs in the same application.

Product Characteristics

Storage Temperature Range.....	-55 °C to +125 °C
Operating Temperature Range.....	-55 °C to +125 °C
Climate Category (IEC 60068-1)	55 / 125 / 21
Moisture Sensitivity Level (MSL)	1
ESD Classification - HBM	N/A

Circuit Diagram

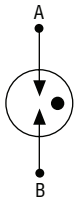

Note: Gas discharge tubes are bidirectional and non-polarized.

Typical Part Marking

Represents total content. Layout may vary.

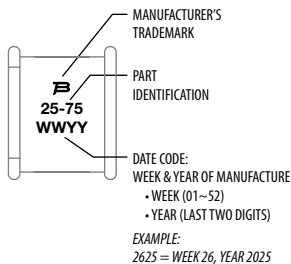

How to Order

Description	GDT 2 5 H - 75 - S1 - RP
GDT = Gas Discharge Tube - Next-generation Model	
Electrodes	2 = 2-Electrode
Size	5 = 5 mm Diameter
High Voltage	75 = 750 V
Package Designator	S1 = 5 x 4.4 mm SMD (Standard)
Packaging Options	RP = Reel Pack (Standard) BK = Bulk

Agency Recognition

Agency	Category	Agency File No.
UL	1449 5th Edition	E313168

Contact Information

www.bourns.com	Phone	Email
Asia-Pacific	+886-2 2562-4117	asiacus@bourns.com
Europe	+36 88 885 877	eurocus@bourns.com
Mexico	+52 614 478 0400	mexicus@bourns.com
The Americas	+1-951 781-5500	americus@bourns.com

* RoHS Directive 2015/863, Mar 31, 2015 and Annex. Specifications are subject to change without notice. Users should verify actual device performance in their specific applications.

The products described herein and this document are subject to specific legal disclaimers as set forth on the last page of this document, and at www.bourns.com/docs/legal/disclaimer.pdf.



Electrical Characteristics (@ T_A = 25 °C Unless Otherwise Noted)

Test Methods per ITU-T K.12, IEEE C62.31 and IEC 61643-311 GDT standards

Bourns Part No.	Device Specifications (1)								
	DC Sparkover Voltage ±20 % (2) (3) (4)	Impulse Sparkover Voltage (2) (5)		Insulation Resistance (IR) (6)	Glow Voltage	Arc Voltage	Glow to Arc Transition Current	Capacitance	DC Holdover Voltage (8)
	100 V/s	100 V/s	1 kV/μs	(7)	10 mA	> 1 A		1 MHz	< 150 ms
GDT25H-75	750 V	1250 V	1400 V	> 2 GΩ	~ 70 V	~ 5 V	< 1 A	<0.6 pF	135 V

Bourns Part No.	Life Ratings (9)					
	Max. Surge Current	Nominal Impulse Discharge Current			Nominal AC Discharge Current	
	8/20 μs	8/20 μs	10/350 μs	10/1000 μs	11 Cycles @ 60 Hz	1 Second
GDT25H-75	10 kA 1 Operation	5 kA 10 Operations	1 kA 1 Operation	100 A 300 Operations	20 Arms 1 Operation	7 Arms 10 Operations

Notes:

- (1) At delivery AQL 0.65 Level II, DIN ISO 2859.
- (2) DC and Impulse Sparkover values are in ionized mode @ 25 °C.
- (3) Bourns recommends reflowing surface mount devices per IPC/ JEDEC J-STD-020 rev. D.
- (4) Surface mount GDTs may exhibit a temporary increase in the DC Sparkover Voltage after the solder reflow process. The DC Sparkover Voltage will recover within 24 hours. There is no quality defect nor change in protection levels during the temporary increase in DC Sparkover Voltage.
- (5) Impulse Sparkover voltage is expressed as a maximum value, with a 99 % probability of measured values within limit.
- (6) IR limits after Life Ratings > 100 MΩ.
- (7) IR Test Voltage: 100 V
- (8) Network applied (per ITU-T K.12 Edition 9.0, Section 7).
- (9) DC Sparkover Voltage limits after Life Ratings may exceed +20 % but will continue to protect without venting (per ITU-T K.12 Edition 9.0, Section 6, where applicable).

Soldering Parameters - Reflow Soldering

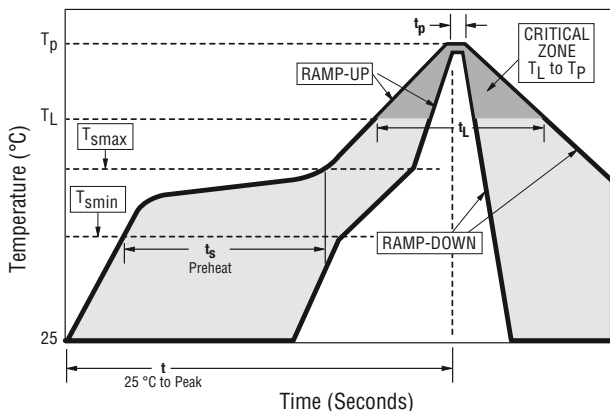

Notes:

Bourns recommends reflowing surface mount devices per IPC/JEDEC J-STD-020 rev D. Surface mounted components (SMD) may exhibit a temporary increase in the DC Sparkover Voltage after the solder reflow process. The components should recover within 24 hours. There is no quality defect nor change in protection levels during the temporary change in DC Sparkover Voltage.

Reflow Condition		Pb-free Assembly
Preheat	Temperature Min. (T _{S(min)})	150 °C
	Temperature Max. (T _{S(max)})	200 °C
	Time (Min. to Max.) (T _S)	60 – 120 seconds
Average Ramp-up Rate (Liquidus Temperature (T _L) to Peak)		3 °C / second max.
T _{S(max)} to T _L - Ramp-up Rate		5 °C / second max.
Reflow	Temperature (T _L) (Liquidus)	217 °C
	Temperature (T _L)	60 – 150 seconds
Peak Temperature (T _p)		260 +0/-5 °C
Time within 5 °C of Actual Peak Temperature (T _p)		10 – 30 seconds
Ramp-down rate		6 °C / second max.
Time from 25 °C to Peak Temperature (T _p)		8 minutes max.
Do not Exceed		260 °C

Soldering Parameters - Hand Soldering

Solder Iron Temperature 350 °C ± 5 °C
 Heating Time 5 seconds max.

Specifications are subject to change without notice. Users should verify actual device performance in their specific applications.

The products described herein and this document are subject to specific legal disclaimers as set forth on the last page of this document, and at www.bourns.com/docs/legal/disclaimer.pdf.



Product Dimensions

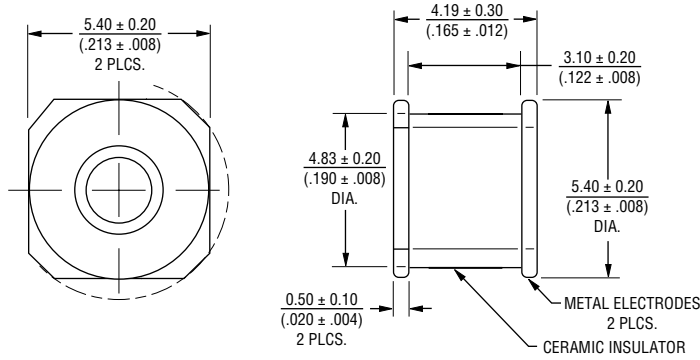

DIMENSIONS: $\frac{\text{MM}}{\text{(INCHES)}}$

Recommended Pad Layout

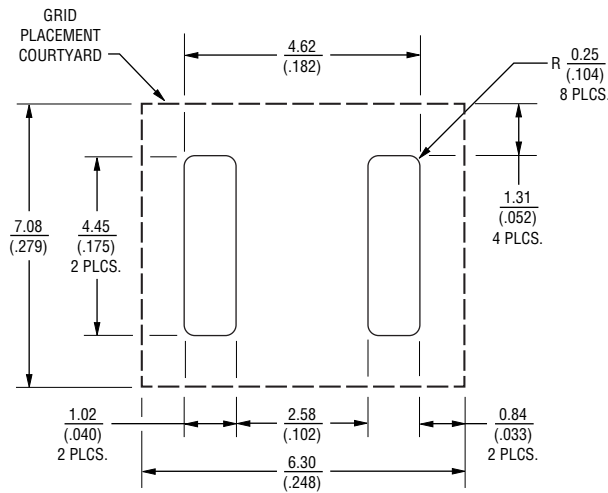

DIMENSIONS: $\frac{\text{MM}}{\text{(INCHES)}}$

Note: Recommended PCB land pattern in compliance with IPC-7351.



Packaging Specifications

Model	Standard Packaging Quantity			
	Bulk (Bag)	Box	Reel	Cut Tape
GDT25H-BK	250 pcs.	1000 pcs.		
GDT25H-RP			1500	

REEL PACK

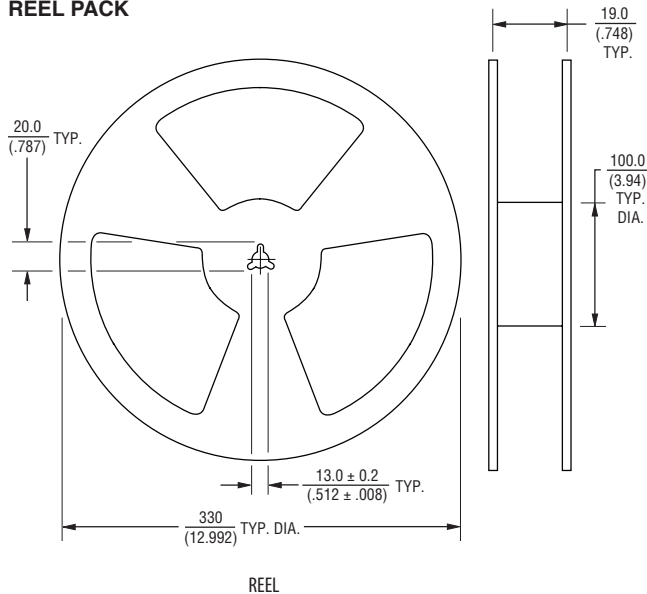

Reel is 330 mm in diameter and 19 mm wide.

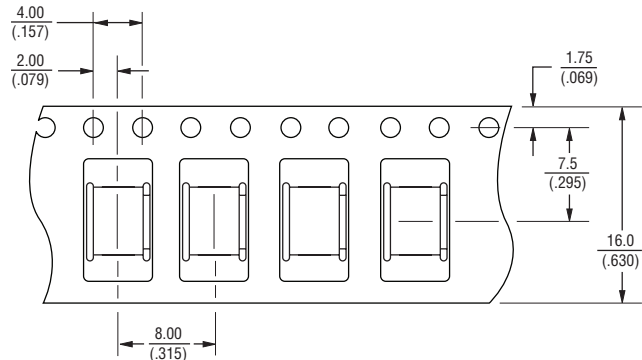

TAPE

DIMENSIONS: $\frac{\text{MM}}{\text{(INCHES)}}$

TOLERANCES (EXCEPT WHERE NOTED): X.X $\frac{\pm 0.3}{(\pm .012)}$

X.XX $\frac{\pm 0.15}{(\pm .006)}$

DEGREES $\pm 1^\circ$

This legal disclaimer applies to purchasers and users of Bourns® products manufactured by or on behalf of Bourns, Inc. and its affiliates (collectively, "Bourns").

Unless otherwise expressly indicated in writing, Bourns® products and data sheets relating thereto are subject to change without notice. Users should check for and obtain the latest relevant information and verify that such information is current and complete before placing orders for Bourns® products.

The characteristics and parameters of a Bourns® product set forth in its data sheet are based on laboratory conditions, and statements regarding the suitability of products for certain "typical" applications are based on Bourns' knowledge of typical requirements in generic applications. Bourns assumes that "typical" applications include failsafe/backup features to address critical risks to users and are designed to allow rework of Bourns® product to avoid scrap of a device solely due to malfunctioning Bourns® product. The characteristics and parameters of a Bourns® product in a user application may vary from the data sheet characteristics and parameters due to (i) the combination of the Bourns® product with other components in the user's application, or (ii) the environment of the user application itself. The characteristics and parameters of a Bourns® product also can and do vary in different applications and actual performance may vary over time. Thus, users should always verify the actual performance of the Bourns® product in their specific devices and applications and make their own independent judgments regarding the suitability of Bourns® product and the amount of additional test margin to design into their device or application to compensate for differences between laboratory and real-world conditions.

Unless Bourns has explicitly designated an individual Bourns® product as meeting the requirements of a particular industry standard (e.g., IATF 16949) or a particular qualification (e.g., UL listed or recognized), Bourns is not responsible for any failure of an individual Bourns® product to meet the requirements of such industry standard or particular qualification even if such industry standard or qualification is a "state of art". Users of Bourns® products are responsible for ensuring compliance with safety-related requirements and standards applicable to their devices or applications.

Bourns® products are not recommended, authorized or intended for use in applications where failure or malfunction may result in personal injury, death, or severe property or environmental damage, such as without limitation nuclear, life-critical medical and certain automotive and aviation applications. Except as set forth in the bullet points below or unless expressly and specifically approved in writing on a case-by-case basis by an authorized Bourns' representative, use of any Bourns® products in such unauthorized high-risk applications is at the user's sole risk.

- Bourns considers implantable/invasive devices and devices/procedures designed as life-supporting or life-sustaining by the U.S. Food and Drug Administration or equivalent organizations outside of the United States as "life-critical" medical applications. Bourns expressly identifies those Bourns® standard products that are suitable for use in typical medical applications that are not life-critical in its publication entitled "Bourns Medical Grade Component Guide."
- Bourns expressly identifies those Bourns® standard products that are suitable for use in typical automotive applications associated with any Automate Safety Integrity Level (ASIL) in its publication entitled "Bourns Automotive Grade Component Guide." Bourns' designation of Bourns® product as compliant with the AEC-Q standard does not by itself mean that Bourns has approved such product for use in an automotive application.
- Bourns expressly identifies Bourns® standard products that are suitable for use in the typical aviation applications/systems requiring System Design Assurance Level (RTCA DO-254 DAL) of C, D or E in its publication entitled "Bourns Civilian Aerospace/Aviation Grade Component Guide." Bourns does not test its products for compliance with United States Federal Aviation Administration standards or any other generally equivalent governmental organization standard applicable to products designed or manufactured for use in aviation applications. Use of Bourns® standard components in aviation applications associated with RTCA DO-254 DAL A or B without proper approval noted above shall be at the user's sole risk.
- Bourns will review and authorize on a case-by-case basis the use of Bourns® standard products which are at least AEC-Q compliant in space-related civil applications (rockets, satellites) with a negotiated cross-waiver and indemnity agreement.

The use and level of testing applicable to Bourns® custom products shall be negotiated on a case-by-case basis by Bourns and the user for which such Bourns® custom products are specially designed. Absent a written agreement between Bourns and the user regarding the use and level of such testing, the above provisions applicable to Bourns® standard products shall also apply to such Bourns® custom products.

Use of Bourns® products or Bourns' technology in military/defense applications must be reviewed with Bourns for compliance with applicable export control laws and embargoes. Users shall not sell, transfer, export or re-export (which includes transfers within a country) any Bourns® products or technology or technical data for use in activities which involve the design, development, production, use or stockpiling of nuclear, chemical or biological weapons or missiles, nor shall they use Bourns® products or technology or technical data in any facility which engages in activities relating to such devices. Further, Bourns® products and Bourns' technology and technical data may not under any circumstance be exported or re-exported to countries subject to international sanctions or embargoes. Bourns® products and technology may not, without prior authorization from Bourns and/or the Government of a country where such product/technology is designed and/or manufactured, be resold, transferred, or re-exported (including within the same country) to any party not eligible to receive commodities, software, and technical data originating in such country.

To the maximum extent permitted by applicable law, Bourns disclaims (i) any and all liability for special, punitive, consequential, incidental or indirect damages or lost revenues or lost profits, and (ii) any and all implied warranties (those not based on parameters specified in Bourns' data sheets and/or specifications), including implied warranties of fitness for particular purpose, non-infringement and merchantability.

For your convenience, copies of this Legal Disclaimer Notice with German, Spanish, Japanese, Traditional Chinese and Simplified Chinese bilingual versions are available at:

Web Page: <https://www.bourns.com/legal/disclaimers-terms-and-policies>

PDF: <https://www.bourns.com/docs/Legal/disclaimer.pdf>

K2540 05/26R



CALIFORNIA WARNING: Can expose you to lead, a carcinogen and reproductive toxicant.

See www.P65Warnings.ca.gov