

## Features

- Absolute encoder / absolute code output
- Digital output
- Sturdy construction
- Bushing mount
- Available with PC board mounting bracket (optional)
- \*RoHS compliant

## EAW - Absolute Contacting Encoder (ACE™)

### General Information

Until now, the choice of an absolute encoder meant an expensive, and larger-sized product. Through the use of combinatorial mathematics, the absolute code pattern of the Bourns® Absolute Contacting Encoder (ACE™) is placed on a single track for a very economical, energy-efficient and compact product. Bourns® ACE™ provides an absolute digital output that will also retain its last position in the event of a power failure.

An intelligent alternative to incremental encoders and potentiometers, the Bourns® ACE™ is ideally suited for many industrial, medical and consumer product applications.

### Recommended Control Diagram for ACE-128

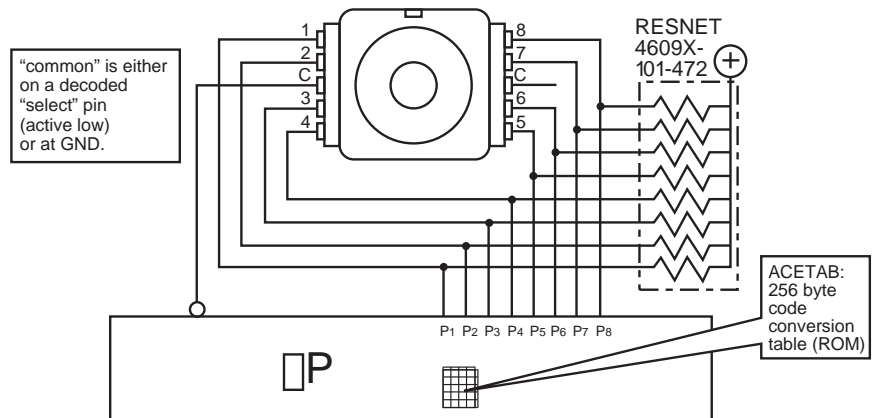

### Electrical Characteristics

Output.....	8-bit code with 128 absolute states
Closed Circuit Resistance.....	5 ohms maximum
Open Circuit Resistance.....	100 K ohms minimum
Contact Rating.....	10 milliamp @ 10 VDC or 0.1 watt maximum
Insulation Resistance (500 VDC).....	1,000 megohms minimum
Dielectric Withstanding Voltage (MIL-STD-202 Method 301).....	
Sea Level.....	1,000 VAC minimum
Electrical Travel.....	Continuous
Contact Bounce (60 RPM).....	2.7 milliseconds maximum*
RPM (Operating).....	120 maximum

### Environmental Characteristics

Operating Temperature Range.....	-40 °C to +85 °C (-40 °F to +185 °F)
Storage Temperature Range.....	-40 °C to +85 °C (-40 °F to +185 °F)
Humidity.....	MIL-STD-202, Method 103B, Condition B
Vibration.....	15 G
Contact Bounce.....	0.1 millisecond maximum
Shock.....	50 G
Contact Bounce.....	0.1 millisecond maximum
Rotational Life.....	50,000 shaft revolutions minimum
IP Rating.....	IP 40

### Mechanical Characteristics

Mechanical Angle.....	360 ° Continuous
Running Torque.....	0.5 to 1.5 N-cm (0.75 to 2.50 oz-in.)
Mounting Torque.....	79 N-cm (7 lb.-in.) maximum
Shaft Side Load (Static).....	4.5 kg (10 lbs.) minimum
Weight.....	Approximately 14 gms. (0.50 oz.)
Terminals.....	Printed circuit board terminals
Soldering Condition.....	
Manual Soldering.....	96.5Sn/3.0Ag/0.5Cu solid wire or no-clean rosin cored wire 370 °C (700 °F) max. for 3 seconds
Wave Soldering.....	96.5Sn/3.0Ag/0.5Cu solder with no-clean ux 260 °C (500 °F) max. for 5 seconds
Wash processes.....	Not recommended
Marking.....	Manufacturer's name and trademark, part number, and date code.
Hardware.....	One lockwasher and one mounting nut are shipped with each encoder, except where noted in the part number.
Packaging.....	45 pcs./tray

\*High probability of missing quadrature codes with maximum bounce.



**WARNING Cancer and Reproductive Harm**  
[www.P65Warnings.ca.gov](http://www.P65Warnings.ca.gov)

\*RoHS Directive 2015/863, Mar 31, 2015 and Annex.

Specifications are subject to change without notice. Users should verify actual device performance in their specific applications. The products described herein and this document are subject to specific legal disclaimers as set forth on the last page of this document, and at [www.bourns.com/docs/legal/disclaimer.pdf](http://www.bourns.com/docs/legal/disclaimer.pdf).

# EAW - Absolute Contacting Encoder (ACE™)



## Pin Output Code For ACE-128

Bit/Pin correlation: b7 b6 b5 b4 b3 b2 b1 b0 = p8 p7 p6 p5 p4 p3 p2 p1  
 A binary "1" denotes an "open" switch and a binary "0" denotes a "closed" switch.  
 Positions 0-127 are seen by a clockwise rotation of the shaft.

Position	p8	p7	p6	p5	p4	p3	p2	p1	Decimal Output
0	0	1	1	1	1	1	1	1	127
1	0	0	1	1	1	1	1	1	63
2	0	0	1	1	1	1	1	0	62
3	0	0	1	1	1	0	1	0	58
4	0	0	1	1	1	0	0	0	56
5	1	0	1	1	1	0	0	0	184
6	1	0	0	1	1	0	0	0	152
7	0	0	0	1	1	0	0	0	24
8	0	0	0	0	1	0	0	0	8
9	0	1	0	0	1	0	0	0	72
10	0	1	0	0	1	0	0	1	73
11	0	1	0	0	1	1	0	1	77
12	0	1	0	0	1	1	1	1	79
13	0	0	0	0	1	1	1	1	15
14	0	0	1	0	1	1	1	1	47
15	1	0	1	0	1	1	1	1	175
16	1	0	1	1	1	1	1	1	191
17	1	0	0	1	1	1	1	1	159
18	0	0	0	1	1	1	1	1	31
19	0	0	0	1	1	1	0	1	29
20	0	0	0	1	1	1	0	0	28
21	0	1	0	1	1	1	0	0	92
22	0	1	0	0	1	1	0	0	76
23	0	0	0	0	1	1	0	0	12
24	0	0	0	0	0	1	0	0	4
25	0	0	1	0	0	1	0	0	36
26	1	0	1	0	0	1	0	0	164
27	1	0	1	0	0	1	1	0	166
28	1	0	1	0	0	1	1	1	167
29	1	0	0	0	0	1	1	1	135
30	1	0	0	1	0	1	1	1	151
31	1	1	0	1	0	1	1	1	215
32	1	1	0	1	1	1	1	1	223
33	1	1	0	0	1	1	1	1	207
34	1	0	0	0	1	1	1	1	143
35	1	0	0	0	1	1	1	0	142
36	0	0	0	0	1	1	1	0	14
37	0	0	1	0	1	1	1	0	46
38	0	0	1	0	0	1	1	0	38
39	0	0	0	0	0	1	1	0	6
40	0	0	0	0	0	0	1	0	2
41	0	0	0	1	0	0	1	0	18
42	0	1	0	1	0	0	1	0	82
43	0	1	0	1	0	0	1	1	83
44	1	1	0	1	0	0	1	1	211
45	1	1	0	0	0	0	1	1	195
46	1	1	0	0	1	0	1	1	203
47	1	1	1	0	1	0	1	1	235
48	1	1	1	0	1	1	1	1	239
49	1	1	1	0	0	1	1	1	231
50	1	1	0	0	0	1	1	1	199
51	0	1	0	0	0	1	1	1	71
52	0	0	0	0	0	1	1	1	7
53	0	0	0	1	0	1	1	1	23
54	0	0	0	1	0	0	1	1	19
55	0	0	0	0	0	0	1	1	3
56	0	0	0	0	0	0	0	1	1
57	0	0	0	0	1	0	0	1	9
58	0	0	1	0	1	0	0	1	41
59	1	0	1	0	1	0	0	1	169
60	1	1	1	0	1	0	0	1	233
61	1	1	1	0	0	0	0	1	225
62	1	1	1	0	0	1	0	1	229
63	1	1	1	1	0	1	0	1	245

Position	p8	p7	p6	p5	p4	p3	p2	p1	Decimal Output
64	1	1	1	1	0	1	1	1	247
65	1	1	1	1	0	0	1	1	243
66	1	1	1	1	0	0	0	1	227
67	1	0	1	0	0	0	1	1	163
68	1	0	0	0	0	0	1	1	131
69	1	0	0	0	1	0	1	1	139
70	1	0	0	0	1	0	0	1	137
71	1	0	0	0	0	0	0	1	129
72	1	0	0	0	0	0	0	0	128
73	1	0	0	0	0	1	0	0	132
74	1	0	0	1	0	1	0	0	148
75	1	1	0	1	0	1	0	0	212
76	1	1	1	1	0	1	0	0	244
77	1	1	1	1	0	0	0	0	240
78	1	1	1	1	1	0	0	1	242
79	1	1	1	1	1	0	1	0	250
80	1	1	1	1	1	0	1	1	251
81	1	1	1	1	1	0	0	1	249
82	1	1	1	1	1	0	0	0	241
83	1	1	0	1	0	0	0	1	209
84	1	1	0	0	0	0	0	1	193
85	1	1	0	0	0	1	0	1	197
86	1	1	0	0	0	1	0	0	196
87	1	1	0	0	0	0	0	0	192
88	0	1	0	0	0	0	0	0	64
89	0	1	0	0	0	0	1	0	66
90	0	1	0	0	1	0	1	0	74
91	0	1	1	0	1	0	1	0	106
92	0	1	1	1	1	0	1	0	122
93	0	1	1	1	1	0	0	0	120
94	0	1	1	1	1	0	0	1	121
95	0	1	1	1	1	1	0	1	125
96	1	1	1	1	1	1	0	1	253
97	1	1	1	1	1	1	0	0	252
98	1	1	1	1	1	0	0	0	248
99	1	1	1	0	1	0	0	0	232
100	1	1	1	0	0	0	0	0	224
101	1	1	1	0	0	0	1	0	226
102	0	1	1	0	0	0	1	0	98
103	0	1	1	0	0	0	0	0	96
104	0	0	1	0	0	0	0	0	32
105	0	0	1	0	0	0	0	1	33
106	0	0	1	0	0	1	0	1	37
107	0	0	1	1	0	1	0	1	53
108	0	0	1	1	1	1	0	1	61
109	0	0	1	1	1	1	0	0	60
110	1	0	1	1	1	1	0	0	188
111	1	0	1	1	1	1	1	0	190
112	1	1	1	1	1	1	1	0	254
113	0	1	1	1	1	1	1	0	126
114	0	1	1	1	1	1	0	0	124
115	0	1	1	1	0	1	0	0	116
116	0	1	1	1	0	0	0	0	112
117	0	1	1	1	0	0	0	1	113
118	0	0	1	1	0	0	0	1	49
119	0	0	1	1	0	0	0	0	48
120	0	0	0	1	0	0	0	0	16
121	1	0	0	1	0	0	0	0	144
122	1	0	0	1	0	0	1	0	146
123	1	0	0	1	1	0	1	0	154
124	1	0	0	1	1	1	1	0	158
125	0	0	0	1	1	1	1	0	30
126	0	1	0	1	1	1	1	0	94
127	0	1	0	1	1	1	1	1	95

Specifications are subject to change without notice.  
 Users should verify actual device performance in their specific applications.  
 The products described herein and this document are subject to specific legal disclaimers as set forth on the last page of this document, and at [www.bourns.com/docs/legal/disclaimer.pdf](http://www.bourns.com/docs/legal/disclaimer.pdf).

# EAW - Absolute Contacting Encoder (ACE™)

**BOURNS®**

## Dimensional Drawings

Bushing Mounted: Housing A with Rear Facing Terminals

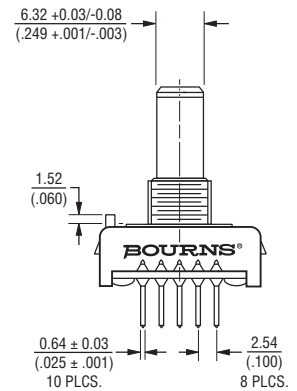
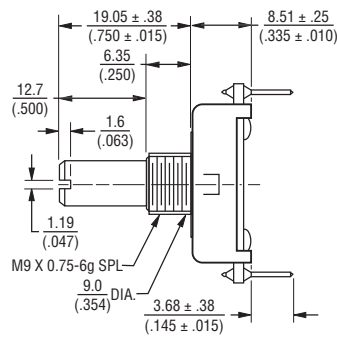
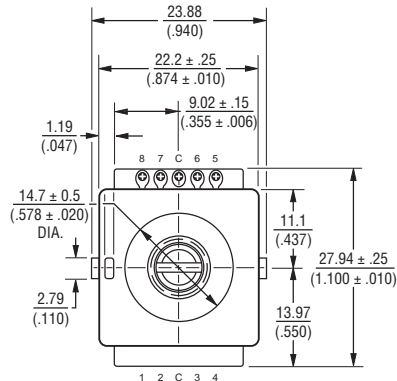

Bushing Mounted: Housing A with Forward Facing Terminals

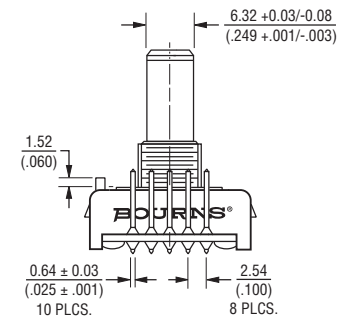
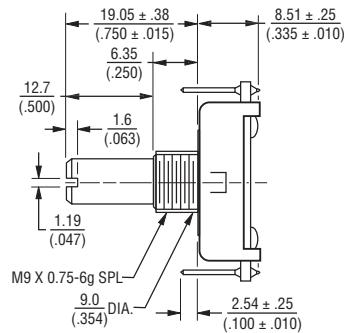
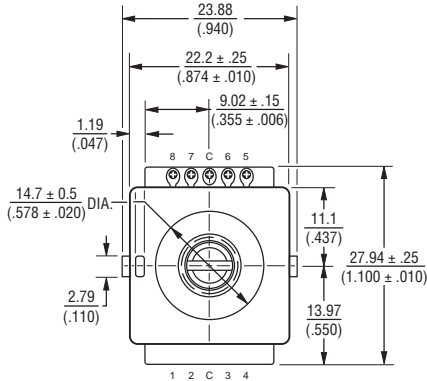

PCB Bracket Mounted: Housing B

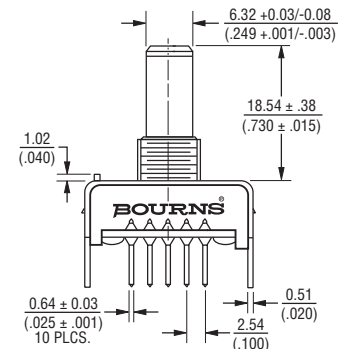
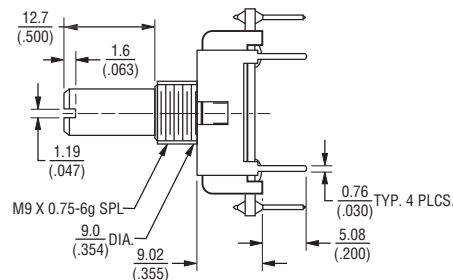
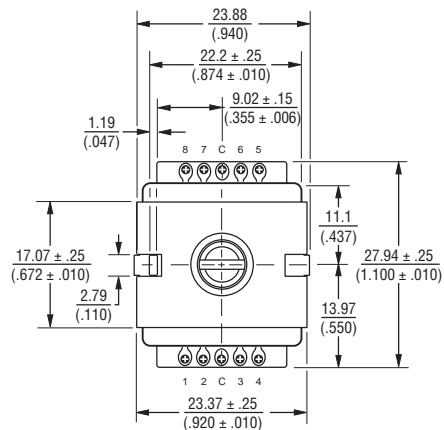

Specifications are subject to change without notice. Users should verify actual device performance in their specific applications. The products described herein and this document are subject to specific legal disclaimers as set forth on the last page of this document, and at [www.bourns.com/docs/legal/disclaimer.pdf](http://www.bourns.com/docs/legal/disclaimer.pdf).

# EAW - Absolute Contacting Encoder (ACE™)

**BOURNS®**

## Dimensional Drawings

Shaft Style B

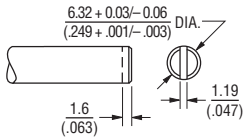

Shaft Style C

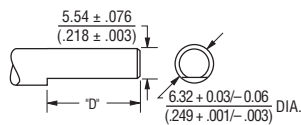

"D" DIMENSION EXTENDS FROM SHAFT END TO BUSHING FACE  
 "D" = (SHAFT LENGTH, FMS) - (BUSHING LENGTH)

Shaft Style R

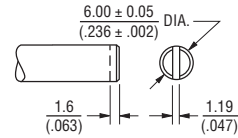

Bushing Mounted: Housing A with Rear Facing Terminals

Panel Hole Dimensions

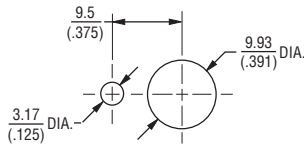

PCB Board Hole Pattern w/PCB Bracket

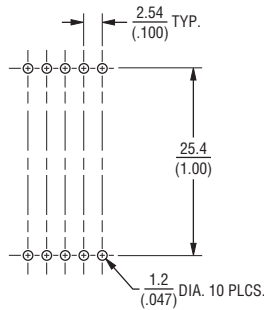

Bushing Mounted: Housing A with Forward Facing Terminals

PCB Board Hole Pattern w/PCB Bracket

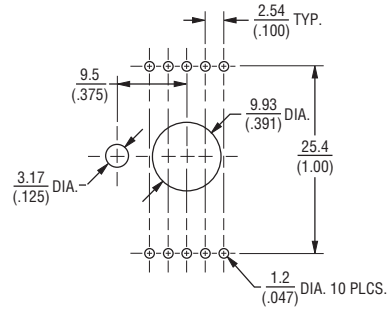

PCB Bracket Mounted: Housing B

Panel Hole Dimensions

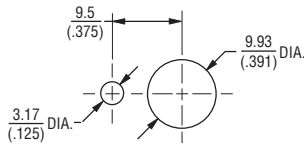

PCB Board Hole Pattern w/PCB Bracket

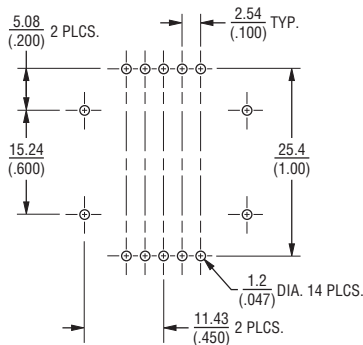

TOLERANCES EXCEPT WHERE NOTED:

.XX = ±  $\frac{.51}{(.02)}$  .XXX = ±  $\frac{.127}{(.005)}$

DIMENSIONS:  $\frac{MM}{(IN)}$

Specifications are subject to change without notice.

Users should verify actual device performance in their specific applications.

The products described herein and this document are subject to specific legal disclaimers as set forth on the last page of this document, and at [www.bourns.com/docs/legal/disclaimer.pdf](http://www.bourns.com/docs/legal/disclaimer.pdf).

# EAW - Absolute Contacting Encoder (ACE™)

**BOURNS®**

## How to Order

### PART NUMBERING SYSTEM

**E A W 0 J - B 2 4 - A E 0 1 2 8 L**

Code	Rotational Life
A	50,000 Revolutions

BUSHING CONFIGURATION	
Code	Description
W	9 mm x 1/4" Length. Threaded M9x0.75
L	9 mm x 3/8" Length. Threaded M9x0.75 (Use B shaft only.)

DETENT CONFIGURATION	
Code	Description
0	Non-Detented

ANTI-ROTATION LUG POSITION	
Code	Description
J	9:00 Position
D	None

SHAFT STYLE (See Outline Drawing for Details)	
Code	Description
B	Plain with Inserted Slot (1/4" Dia.)
C	Single Flatted (1/4" Dia.)
R	Plain with Inserted Slot (6 mm Dia.)

RoHS IDENTIFIER	
Code	Description
L	Compliant

PERFORMANCE CODE		
Code	Detents	States/Rev.
E0128	0	128

HOUSING TERMINAL CONFIGURATION (X indicates "Equipped With")					
Code					
Features	A	B	C	H	K
Rear Mount Terminals	X	X	X		
Forward Facing Terminals				X	X
PCB Bracket		X	X		
Hardware Included	X		X	X	

SHAFT LENGTH (FMS)		
Code	Description	Available Shaft Styles
24	3/4" (19.05 mm) Length	B, C
Metric		
19	19 mm Length	R

The sample part number demonstrates the identification code for Bourns contacting encoders.

The part number shown is a commonly used model, typically available from stock.

\*Consult factory concerning special inquiries.

REV. 09/19

Specifications are subject to change without notice.

Users should verify actual device performance in their specific applications.

The products described herein and this document are subject to specific legal disclaimers as set forth on the last page of this document, and at [www.bourns.com/docs/legal/disclaimer.pdf](http://www.bourns.com/docs/legal/disclaimer.pdf).

This legal disclaimer applies to purchasers and users of Bourns® products manufactured by or on behalf of Bourns, Inc. and its affiliates (collectively, "Bourns").

Unless otherwise expressly indicated in writing, Bourns® products and data sheets relating thereto are subject to change without notice. Users should check for and obtain the latest relevant information and verify that such information is current and complete before placing orders for Bourns® products.

The characteristics and parameters of a Bourns® product set forth in its data sheet are based on laboratory conditions, and statements regarding the suitability of products for certain "typical" applications are based on Bourns' knowledge of typical requirements in generic applications. Bourns assumes that "typical" applications include failsafe/backup features to address critical risks to users and are designed to allow rework of Bourns® product to avoid scrap of a device solely due to malfunctioning Bourns® product. The characteristics and parameters of a Bourns® product in a user application may vary from the data sheet characteristics and parameters due to (i) the combination of the Bourns® product with other components in the user's application, or (ii) the environment of the user application itself. The characteristics and parameters of a Bourns® product also can and do vary in different applications and actual performance may vary over time. Thus, users should always verify the actual performance of the Bourns® product in their specific devices and applications and make their own independent judgments regarding the suitability of Bourns® product and the amount of additional test margin to design into their device or application to compensate for differences between laboratory and real-world conditions.

Unless Bourns has explicitly designated an individual Bourns® product as meeting the requirements of a particular industry standard (e.g., IATF 16949) or a particular qualification (e.g., UL listed or recognized), Bourns is not responsible for any failure of an individual Bourns® product to meet the requirements of such industry standard or particular qualification even if such industry standard or qualification is a "state of art". Users of Bourns® products are responsible for ensuring compliance with safety-related requirements and standards applicable to their devices or applications.

Bourns® products are not recommended, authorized or intended for use in applications where failure or malfunction may result in personal injury, death, or severe property or environmental damage, such as without limitation nuclear, life-critical medical and certain automotive and aviation applications. Except as set forth in the bullet points below or unless expressly and specifically approved in writing on a case-by-case basis by an authorized Bourns' representative, use of any Bourns® products in such unauthorized high-risk applications is at the user's sole risk.

- Bourns considers implantable/invasive devices and devices/procedures designed as life-supporting or life-sustaining by the U.S. Food and Drug Administration or equivalent organizations outside of the United States as "life-critical" medical applications. Bourns expressly identifies those Bourns® standard products that are suitable for use in typical medical applications that are not life-critical in its publication entitled "Bourns Medical Grade Component Guide."
- Bourns expressly identifies those Bourns® standard products that are suitable for use in typical automotive applications associated with any Automate Safety Integrity Level (ASIL) in its publication entitled "Bourns Automotive Grade Component Guide." Bourns' designation of Bourns® product as compliant with the AEC-Q standard does not by itself mean that Bourns has approved such product for use in an automotive application.
- Bourns expressly identifies Bourns® standard products that are suitable for use in the typical aviation applications/systems requiring System Design Assurance Level (RTCA DO-254 DAL) of C, D or E in its publication entitled "Bourns Civilian Aerospace/Aviation Grade Component Guide." Bourns does not test its products for compliance with United States Federal Aviation Administration standards or any other generally equivalent governmental organization standard applicable to products designed or manufactured for use in aviation applications. Use of Bourns® standard components in aviation applications associated with RTCA DO-254 DAL A or B without proper approval noted above shall be at the user's sole risk.
- Bourns will review and authorize on a case-by-case basis the use of Bourns® standard products which are at least AEC-Q compliant in space-related civil applications (rockets, satellites) with a negotiated cross-waiver and indemnity agreement.

The use and level of testing applicable to Bourns® custom products shall be negotiated on a case-by-case basis by Bourns and the user for which such Bourns® custom products are specially designed. Absent a written agreement between Bourns and the user regarding the use and level of such testing, the above provisions applicable to Bourns® standard products shall also apply to such Bourns® custom products.

Use of Bourns® products or Bourns' technology in military/defense applications must be reviewed with Bourns for compliance with applicable export control laws and embargoes. Users shall not sell, transfer, export or re-export (which includes transfers within a country) any Bourns® products or technology or technical data for use in activities which involve the design, development, production, use or stockpiling of nuclear, chemical or biological weapons or missiles, nor shall they use Bourns® products or technology or technical data in any facility which engages in activities relating to such devices. Further, Bourns® products and Bourns' technology and technical data may not under any circumstance be exported or re-exported to countries subject to international sanctions or embargoes. Bourns® products and technology may not, without prior authorization from Bourns and/or the Government of a country where such product/technology is designed and/or manufactured, be resold, transferred, or re-exported (including within the same country) to any party not eligible to receive commodities, software, and technical data originating in such country.

To the maximum extent permitted by applicable law, Bourns disclaims (i) any and all liability for special, punitive, consequential, incidental or indirect damages or lost revenues or lost profits, and (ii) any and all implied warranties (those not based on parameters specified in Bourns' data sheets and/or specifications), including implied warranties of fitness for particular purpose, non-infringement and merchantability.

For your convenience, copies of this Legal Disclaimer Notice with German, Spanish, Japanese, Traditional Chinese and Simplified Chinese bilingual versions are available at:

Web Page: <https://www.bourns.com/legal/disclaimers-terms-and-policies>

PDF: <https://www.bourns.com/docs/Legal/disclaimer.pdf>