



## Features

- Formerly a **KEKOVARICON** product
- Five model sizes available - 7, 10, 14, 20 and 23 mm
- Broad range of current and energy handling capabilities
- 60 to 550  $V_{rms}$  AC voltage range; higher voltages available upon request

- 85 to 745 Vdc DC operating voltage range
- Available in tape and reel packaging for automatic pick-and-place (7-20 mm)
- RoHS compliant\*

## CVQ Series – Extended Medium Voltage Disc Varistors

### General Information

The CVQ series of transient surge suppressors is the extended version of CV series disc shaped varistors. The CVQ series consists of 7 mm, 10 mm, 14 mm, 20 mm and 23 mm sized varistors with extremely high current and energy capabilities. This series provides an increased level of protection for the transients expected in telecommunication and AC power networks. The AC operating voltage of these varistors ranges from 60 V to 550 V.

### Absolute Maximum Ratings

Parameter	Value	Units
<b>Continuous:</b>		
Steady State Applied Voltage		
DC Voltage Range ( $V_{dc}$ )	85 to 745	V
AC Voltage Range ( $V_{rms}$ )	60 to 550	V
<b>Transient:</b>		
Peak Single Pulse Surge Current, 8/20 $\mu s$ Waveform ( $I_{max}$ )	1750 to 15000	A
Single Pulse Surge Energy, 10/1000 $\mu s$ Waveform ( $W_{max}$ )	9 to 627	J
Operating Ambient Temperature	-40 to +85	$^{\circ}C$
Storage Temperature Range	-40 to +125	$^{\circ}C$
Threshold Voltage Temperature Coefficient	< +0.05	%/ $^{\circ}C$
Insulation Resistance	> 1	G $\Omega$
Isolation Voltage Capability	> 2.5	kV
Response Time	< 25	ns
Climatic Category	40 / 85 / 56	

### Additional Information

Click these links for more information:



[PRODUCT SELECTOR](#) [TECHNICAL LIBRARY](#) [INVENTORY](#) [SAMPLES](#) [CONTACT](#)

### Agency Recognition

Standard	UL 1449
File Number	<a href="#">E313168**</a>

\*\*Not all rated voltages are UL recognized; check the file for details.

### Varistor Symbol

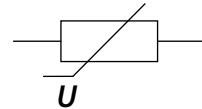

### Index

Features .....	<a href="#">1</a>
General Information .....	<a href="#">1</a>
Agency Recognition .....	<a href="#">1</a>
Varistor Symbol .....	<a href="#">1</a>
Summary of Custom Varistor Options .....	<a href="#">1</a>
Absolute Maximum Ratings .....	<a href="#">1</a>
Device Ratings .....	<a href="#">2-3</a>
Product Dimensions .....	<a href="#">4-6</a>
How to Order .....	<a href="#">7</a>
Typical Part Marking .....	<a href="#">7</a>
Pulse Rating Curves .....	<a href="#">7-9</a>
Packaging Drawings .....	<a href="#">10</a>
Packaging Specifications .....	<a href="#">11-12</a>
Assembly / Soldering	
Recommendations for Through-Hole Components .....	<a href="#">13</a>
Reliability Testing Procedures .....	<a href="#">14-15</a>
Terminology .....	<a href="#">16</a>
Legal Disclaimer .....	<a href="#">17</a>

**BOURNS®**

Asia-Pacific: Tel: +886-2 2562-4117 • Email: [asiacus@bourns.com](mailto:asiacus@bourns.com)

EMEA: Tel: +36 88 885 877 • Email: [euocus@bourns.com](mailto:euocus@bourns.com)

The Americas: Tel: +1-951 781-5500 • Email: [americus@bourns.com](mailto:americus@bourns.com)

[www.bourns.com](http://www.bourns.com)



**WARNING Cancer and Reproductive Harm - [www.P65Warnings.ca.gov](http://www.P65Warnings.ca.gov)**

\*RoHS Directive 2015/863, Mar 31, 2015 and Annex.

Specifications are subject to change without notice.

Users should verify actual device performance in their specific applications.

The products described herein and this document are subject to specific legal disclaimers as set forth on the last page of this document, and at [www.bourns.com/docs/legal/disclaimer.pdf](http://www.bourns.com/docs/legal/disclaimer.pdf).

# CVQ Series – Extended Medium Voltage Disc Varistors



## Device Ratings

Model	V <sub>rms</sub>	V <sub>dc</sub>	V <sub>n</sub> @ 1 mA	V <sub>c</sub>	I <sub>c</sub>	W <sub>max</sub> 10/1000 μs	P max.	I <sub>max</sub> 8/20 μs	C Typ. @ 1 kHz
	V	V	V	V	A	J	W	A	pF
CVQ 60 K 7	60	85	100	165	10	9	0.25	1750	680
CVQ 60 K 10	60	85	100	165	25	18	0.4	3500	1200
CVQ 60 K 14	60	85	100	165	50	38	0.6	6000	2200
CVQ 60 K 20	60	85	100	165	100	77	1	12000	4100
CVQ 75 K 7	75	100	120	200	10	11	0.25	1750	550
CVQ 75 K 10	75	100	120	200	25	24	0.4	3500	950
CVQ 75 K 14	75	100	120	200	50	46	0.6	6000	1800
CVQ 75 K 20	75	100	120	200	100	88	1	12000	3300
CVQ 95 K 7	95	125	150	250	10	14	0.25	1750	440
CVQ 95 K 10	95	125	150	250	25	28	0.4	3500	750
CVQ 95 K 14	95	125	150	250	50	58	0.6	6000	1400
CVQ 95 K 20	95	125	150	250	100	116	1	12000	2600
CVQ 115 K 7	115	150	180	300	10	16	0.25	1750	360
CVQ 115 K 10	115	150	180	300	25	34	0.4	3500	650
CVQ 115 K 14	115	150	180	300	50	71	0.6	6000	1200
CVQ 115 K 20	115	150	180	300	100	128	1	12000	2100
CVQ 130 K 7	130	170	205	340	10	19	0.25	1750	360
CVQ 130 K 10	130	170	205	340	25	38	0.4	3500	580
CVQ 130 K 14	130	170	205	340	50	77	0.6	6000	1050
CVQ 130 K 20	130	170	205	340	100	154	1	12000	1900
CVQ 130 K 23	130	170	205	340	100	172	1	15000	3500
CVQ 140 K 7	140	180	220	360	10	22	0.25	1750	300
CVQ 140 K 10	140	180	220	360	25	42	0.4	3500	540
CVQ 140 K 14	140	180	220	360	50	85	0.6	6000	980
CVQ 140 K 20	140	180	220	360	100	170	1	12000	1800
CVQ 140 K 23	140	180	220	360	100	190	1	15000	3200
CVQ 150 K 7	150	200	240	395	10	23	0.25	1750	280
CVQ 150 K 10	150	200	240	395	25	46	0.4	3500	510
CVQ 150 K 14	150	200	240	395	50	92	0.6	6000	900
CVQ 150 K 20	150	200	240	395	100	185	1	12000	1600
CVQ 150 K 23	150	200	240	395	100	207	1	15000	2900
CVQ 175 K 7	175	225	270	455	10	26	0.25	1750	250
CVQ 175 K 10	175	225	270	455	25	53	0.4	3500	440
CVQ 175 K 14	175	225	270	455	50	108	0.6	6000	800
CVQ 175 K 20	175	225	270	455	100	210	1	12000	1400
CVQ 175 K 23	175	225	270	455	100	235	1	15000	2500
CVQ 230 K 7	230	300	360	595	10	35	0.25	1750	190
CVQ 230 K 10	230	300	360	595	25	71	0.4	3500	350
CVQ 230 K 14	230	300	360	595	50	143	0.6	6000	620
CVQ 230 K 20	230	300	360	595	100	280	1	12000	1100
CVQ 230 K 23	230	300	360	595	100	313	1	15000	2200
CVQ 250 K 7	250	320	390	650	10	38	0.25	1750	180
CVQ 250 K 10	250	320	390	650	25	77	0.4	3500	320
CVQ 250 K 14	250	320	390	650	50	154	0.6	6000	580
CVQ 250 K 20	250	320	390	650	100	300	1	12000	1000

Continued on Next Page

Specifications are subject to change without notice.

Users should verify actual device performance in their specific applications.

The products described herein and this document are subject to specific legal disclaimers as set forth on the last page of this document, and at [www.bourns.com/docs/legal/disclaimer.pdf](http://www.bourns.com/docs/legal/disclaimer.pdf).

# CVQ Series – Extended Medium Voltage Disc Varistors



## Device Ratings (Continued)

Model	V <sub>rms</sub>	V <sub>dc</sub>	V <sub>n</sub> @ 1 mA	V <sub>c</sub>	I <sub>c</sub>	W <sub>max</sub> 10/1000 μs	P max.	I <sub>max</sub> 8/20 μs	C Typ. @ 1 kHz
	V	V	V	V	A	J	W	A	pF
CVQ 250 K 23	250	320	390	650	100	336	1	15000	1900
CVQ 275 K 7	275	350	430	710	10	44	0.25	1750	160
CVQ 275 K 10	275	350	430	710	25	88	0.4	3500	300
CVQ 275 K 14	275	350	430	710	50	170	0.6	6000	530
CVQ 275 K 20	275	350	430	710	100	330	1	12000	900
CVQ 275 K 23	275	350	430	710	100	370	1	15000	1600
CVQ 300 K 7	300	385	470	775	10	46	0.25	1750	150
CVQ 300 K 10	300	385	470	775	25	93	0.4	3500	280
CVQ 300 K 14	300	385	470	775	50	192	0.6	6000	490
CVQ 300 K 20	300	385	470	775	100	380	1	12000	850
CVQ 300 K 23	300	385	470	775	100	426	1	15000	1300
CVQ 320 K 10	320	420	510	840	25	104	0.4	3500	260
CVQ 320 K 14	320	420	510	840	50	209	0.6	6000	460
CVQ 320 K 20	320	420	510	840	100	420	1	12000	800
CVQ 320 K 23	320	420	510	840	100	470	1	15000	1100
CVQ 385 K 10	385	505	620	1025	25	106	0.4	3500	230
CVQ 385 K 14	385	505	620	1025	50	219	0.6	6000	390
CVQ 385 K 20	385	505	620	1025	100	430	1	12000	650
CVQ 385 K 23	385	505	620	1025	100	480	1	15000	1000
CVQ 420 K 10	420	560	680	1120	25	110	0.4	3500	210
CVQ 420 K 14	420	560	680	1120	50	230	0.6	6000	370
CVQ 420 K 20	420	560	680	1120	100	460	1	12000	620
CVQ 420 K 23	420	560	680	1120	100	515	1	15000	950
CVQ 460 K 10	460	615	750	1240	25	120	0.4	3500	200
CVQ 460 K 14	460	615	750	1240	50	250	0.6	6000	340
CVQ 460 K 20	460	615	750	1240	100	500	1	12000	560
CVQ 460 K 23	460	615	750	1240	100	560	1	15000	900
CVQ 510 K 10	510	670	820	1355	25	131	0.4	3500	180
CVQ 510 K 14	510	670	820	1355	50	258	0.6	6000	310
CVQ 510 K 20	510	670	820	1355	100	520	1	12000	510
CVQ 510 K 23	510	670	820	1355	100	582	1	15000	650
CVQ 550 K 10	550	745	910	1500	25	153	0.4	3500	170
CVQ 550 K 14	550	745	910	1500	50	300	0.6	6000	290
CVQ 550 K 20	550	745	910	1500	100	560	1	12000	480
CVQ 550 K 23	550	745	910	1500	100	627	1	15000	800

Specifications are subject to change without notice.

Users should verify actual device performance in their specific applications.

The products described herein and this document are subject to specific legal disclaimers as set forth on the last page of this document, and at [www.bourns.com/docs/legal/disclaimer.pdf](http://www.bourns.com/docs/legal/disclaimer.pdf).

# CVQ Series – Extended Medium Voltage Disc Varistors

**BOURNS®**

## Product Dimensions

Model	Dimension					
	D (Max.)	t (Max.)	R	d	h (Max.)	a
CVQ 60 K 7	9 (.354)	3.5 (.138)	5 (.197)	0.6 (.024)	11.5 (.453)	1.1 (.043)
CVQ 60 K 10	12.5 (.492)	4.1 (.161)	7.5 (.295)	0.8 (.031)	15 (.591)	1.4 (.055)
CVQ 60 K 14	16.5 (.650)	4.2 (.165)	7.5 (.295)	0.8 (.031)	20 (.787)	1.5 (.059)
CVQ 60 K 20	22.5 (.886)	4.6 (.186)	10 (.394)	1.0 (.039)	26 (1.024)	1.7 (.067)
CVQ 75 K 7	9 (.354)	3.6 (.142)	5 (.197)	0.6 (.024)	11.5 (.453)	1.2 (.047)
CVQ 75 K 10	12.5 (.492)	4.2 (.165)	7.5 (.295)	0.8 (.031)	15 (.591)	1.5 (.059)
CVQ 75 K 14	16.5 (.650)	4.2 (.165)	7.5 (.295)	0.8 (.031)	20 (.787)	1.5 (.059)
CVQ 75 K 20	22.5 (.886)	4.6 (.186)	10 (.394)	1.0 (.039)	26 (1.024)	1.7 (.067)
CVQ 95 K 7	9 (.354)	3.8 (.150)	5 (.197)	0.6 (.024)	11.5 (.453)	1.4 (.055)
CVQ 95 K 10	12 (.472)	4.3 (.169)	7.5 (.295)	0.8 (.031)	15 (.591)	1.7 (.067)
CVQ 95 K 14	16 (.630)	4.3 (.169)	7.5 (.295)	0.8 (.031)	20 (.787)	1.7 (.067)
CVQ 95 K 20	22.5 (.886)	4.6 (.186)	10 (.394)	1.0 (.039)	26 (1.024)	1.9 (.075)
CVQ 115 K 7	9 (.354)	4.0 (.157)	5 (.197)	0.6 (.024)	11.5 (.453)	1.6 (.063)
CVQ 115 K 10	12.5 (.492)	4.3 (.169)	7.5 (.295)	0.8 (.031)	15 (.591)	1.9 (.075)
CVQ 115 K 14	16.5 (.650)	4.4 (.173)	7.5 (.295)	0.8 (.031)	20 (.787)	1.9 (.075)
CVQ 115 K 20	22.5 (.886)	4.8 (.189)	10 (.394)	1.0 (.039)	26 (1.024)	2.1 (.083)
CVQ 130 K 7	9 (.354)	4.0 (.157)	5 (.197)	0.6 (.024)	11.5 (.453)	1.8 (.071)
CVQ 130 K 10	12.5 (.492)	4.5 (.177)	7.5 (.295)	0.8 (.031)	15 (.591)	2.0 (.079)
CVQ 130 K 14	16.5 (.650)	4.6 (.181)	7.5 (.295)	0.8 (.031)	20 (.787)	2.0 (.079)
CVQ 130 K 20	22.5 (.886)	5.0 (.197)	10 (.394)	1.0 (.039)	26 (1.024)	2.2 (.087)
CVQ 130 K 23	25 (.984)	5.0 (.197)	10 (.394)	1.0 (.039)	27 (1.063)	2.2 (.087)
CVQ 140 K 7	9 (.354)	4.1 (.161)	5 (.197)	0.6 (.024)	11.5 (.453)	1.9 (.075)
CVQ 140 K 10	12.5 (.492)	4.6 (.181)	7.5 (.295)	0.8 (.031)	15 (.591)	2.1 (.083)
CVQ 140 K 14	16.5 (.650)	4.7 (.185)	7.5 (.295)	0.8 (.031)	20 (.787)	2.1 (.083)
CVQ 140 K 20	22.5 (.886)	5.1 (.201)	10 (.394)	1.0 (.039)	26 (1.024)	2.3 (.091)
CVQ 140 K 23	25 (.984)	5.1 (.201)	10 (.394)	1.0 (.039)	27 (1.063)	2.3 (.091)
CVQ 150 K 7	9 (.354)	4.3 (.169)	5 (.197)	0.6 (.024)	11.5 (.453)	2.0 (.079)
CVQ 150 K 10	12.5 (.492)	4.6 (.181)	7.5 (.295)	0.8 (.031)	15 (.591)	2.2 (.087)
CVQ 150 K 14	16.5 (.650)	4.8 (.189)	7.5 (.295)	0.8 (.031)	20 (.787)	2.2 (.087)
CVQ 150 K 20	22.5 (.886)	5.2 (.205)	10 (.394)	1.0 (.039)	26 (1.024)	2.4 (.094)

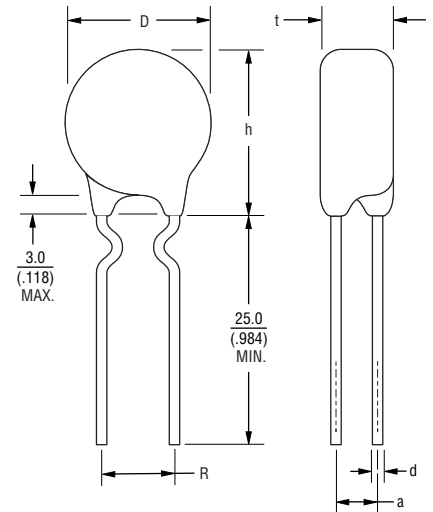
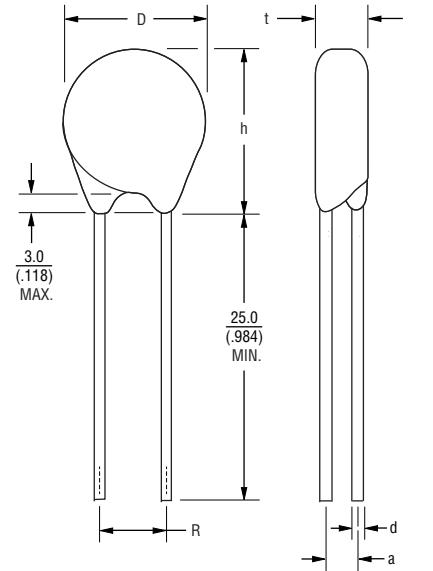

DIMENSIONS:  $\frac{\text{MM}}{\text{(INCHES)}}$

Specifications are subject to change without notice.

Users should verify actual device performance in their specific applications.

The products described herein and this document are subject to specific legal disclaimers as set forth on the last page of this document, and at [www.bourns.com/docs/legal/disclaimer.pdf](http://www.bourns.com/docs/legal/disclaimer.pdf).

# CVQ Series – Extended Medium Voltage Disc Varistors

**BOURNS®**

## Product Dimensions (Continued)

Model	Dimension					
	D (Max.)	t (Max.)	R	d	h (Max.)	a
CVQ 150 K 23	25 (.984)	5.2 (.205)	10 (.394)	1.0 (.039)	27 (1.063)	2.4 (.094)
CVQ 175 K 7	9 (.354)	4.8 (.189)	5 (.197)	0.6 (.024)	11.5 (.453)	2.1 (.083)
CVQ 175 K 10	12.5 (.492)	4.9 (.193)	7.5 (.295)	0.8 (.031)	15 (.591)	2.3 (.091)
CVQ 175 K 14	16.5 (.650)	4.9 (.193)	7.5 (.295)	0.8 (.031)	20 (.787)	2.3 (.091)
CVQ 175 K 20	22.5 (.886)	5.3 (.209)	10 (.394)	1.0 (.039)	26 (1.024)	2.5 (.098)
CVQ 175 K 23	25 (.984)	5.3 (.209)	10 (.394)	1.0 (.039)	27 (1.063)	2.5 (.098)
CVQ 230 K 7	9 (.354)	4.8 (.189)	5 (.197)	0.6 (.024)	11.5 (.453)	2.6 (.102)
CVQ 230 K 10	12.5 (.492)	5.4 (.213)	7.5 (.295)	0.8 (.031)	15 (.591)	2.8 (.110)
CVQ 230 K 14	16.5 (.650)	5.5 (.217)	7.5 (.295)	0.8 (.031)	20 (.787)	2.8 (.110)
CVQ 230 K 20	22.5 (.886)	5.9 (.232)	10 (.394)	1.0 (.039)	26 (1.024)	3.0 (.118)
CVQ 230 K 23	25 (.984)	5.9 (.232)	10 (.394)	1.0 (.039)	27 (1.063)	3.0 (.118)
CVQ 250 K 7	9 (.354)	5.0 (.197)	5 (.197)	0.6 (.024)	11.5 (.453)	2.8 (.110)
CVQ 250 K 10	12.5 (.492)	5.6 (.220)	7.5 (.295)	0.8 (.031)	15 (.591)	3.0 (.118)
CVQ 250 K 14	16.5 (.650)	5.7 (.224)	7.5 (.295)	0.8 (.031)	20 (.787)	3.0 (.118)
CVQ 250 K 20	22.5 (.886)	6.1 (.240)	10 (.394)	1.0 (.039)	26 (1.024)	3.2 (.126)
CVQ 250 K 23	25 (.984)	6.1 (.240)	10 (.394)	1.0 (.039)	27 (1.063)	3.2 (.126)
CVQ 275 K 7	9 (.354)	5.6 (.220)	5 (.197)	0.6 (.024)	11.5 (.453)	3.0 (.118)
CVQ 275 K 10	12.5 (.492)	5.8 (.228)	7.5 (.295)	0.8 (.031)	15 (.591)	3.2 (.126)
CVQ 275 K 14	16.5 (.650)	5.9 (.232)	7.5 (.295)	0.8 (.031)	20 (.787)	3.2 (.126)
CVQ 275 K 20	22.5 (.886)	6.3 (.248)	10 (.394)	1.0 (.039)	26 (1.024)	3.4 (.134)
CVQ 275 K 23	25 (.984)	6.3 (.248)	10 (.394)	1.0 (.039)	27 (1.063)	3.4 (.134)
CVQ 300 K 7	9 (.354)	5.8 (.228)	5 (.197)	0.6 (.024)	11.5 (.453)	3.2 (.126)
CVQ 300 K 10	12.5 (.492)	6.1 (.240)	7.5 (.295)	0.8 (.031)	15 (.591)	3.4 (.134)
CVQ 300 K 14	16.5 (.650)	6.1 (.240)	7.5 (.295)	0.8 (.031)	20 (.787)	3.4 (.134)
CVQ 300 K 20	22.5 (.886)	6.0 (.236)	10 (.394)	1.0 (.039)	27 (1.063)	3.6 (.142)
CVQ 300 K 23	25 (.984)	6.6 (.260)	10 (.394)	1.0 (.039)	29 (1.142)	3.6 (.142)
CVQ 320 K 10	12.5 (.492)	5.9 (.232)	7.5 (.295)	0.8 (.031)	16 (.630)	3.6 (.142)
CVQ 320 K 14	16.5 (.650)	6.5 (.256)	7.5 (.295)	0.8 (.031)	21 (.827)	3.6 (.142)
CVQ 320 K 20	22.5 (.886)	6.8 (.268)	10 (.394)	1.0 (.039)	27 (1.063)	3.8 (.150)
CVQ 320 K 23	25 (.984)	6.8 (.268)	10 (.394)	1.0 (.039)	29 (1.142)	3.8 (.150)

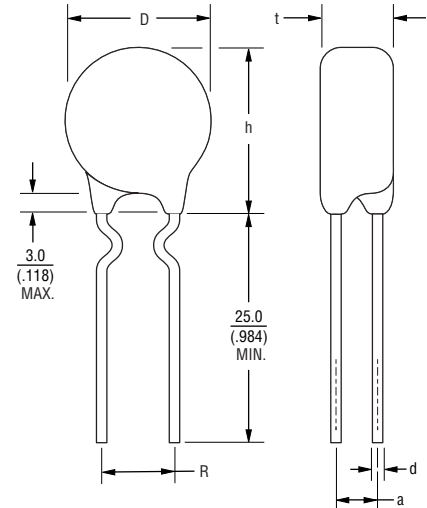
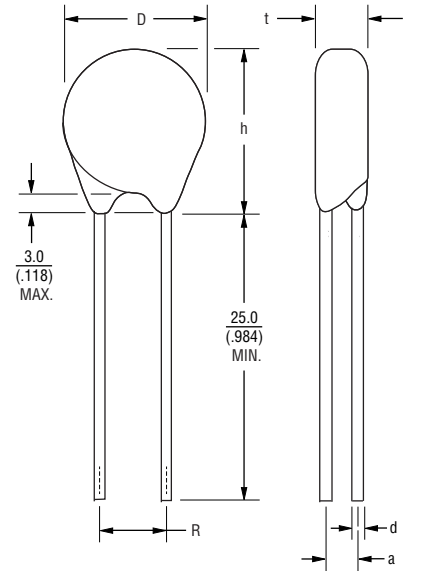

DIMENSIONS:  $\frac{\text{MM}}{\text{(INCHES)}}$

Specifications are subject to change without notice.

Users should verify actual device performance in their specific applications.

The products described herein and this document are subject to specific legal disclaimers as set forth on the last page of this document, and at [www.bourns.com/docs/legal/disclaimer.pdf](http://www.bourns.com/docs/legal/disclaimer.pdf).

# CVQ Series – Extended Medium Voltage Disc Varistors

**BOURNS®**

## Product Dimensions (Continued)

Model	Dimension					
	D (Max.)	t (Max.)	R	d	h (Max.)	a
CVQ 385 K 10	12.5 (.492)	6.4 (.252)	7.5 (.295)	0.8 (.031)	16 (.630)	4.2 (.165)
CVQ 385 K 14	16.5 (.650)	6.9 (.272)	7.5 (.295)	0.8 (.031)	21 (.827)	4.2 (.165)
CVQ 385 K 20	22.5 (.886)	7.5 (.295)	10 (.394)	1.0 (.039)	27 (1.063)	4.4 (.173)
CVQ 385 K 23	25 (.984)	7.5 (.295)	10 (.394)	1.0 (.039)	29 (1.142)	4.4 (.173)
CVQ 420 K 10	12.5 (.492)	7.3 (.287)	7.5 (.295)	0.8 (.031)	16 (.630)	4.4 (.173)
CVQ 420 K 14	16.5 (.650)	7.4 (.291)	7.5 (.295)	0.8 (.031)	21 (.827)	4.4 (.173)
CVQ 420 K 20	22.5 (.886)	7.8 (.307)	10 (.394)	1.0 (.039)	27 (1.063)	4.6 (.181)
CVQ 420 K 23	25 (.984)	7.8 (.307)	10 (.394)	1.0 (.039)	29 (1.142)	4.6 (.181)
CVQ 460 K 10	12.5 (.492)	7.8 (.307)	7.5 (.295)	0.8 (.031)	16 (.630)	4.8 (.189)
CVQ 460 K 14	16.5 (.650)	7.8 (.307)	7.5 (.295)	0.8 (.031)	21 (.827)	4.8 (.189)
CVQ 460 K 20	22.5 (.886)	8.2 (.323)	10 (.394)	1.0 (.039)	27 (1.063)	5.0 (.197)
CVQ 460 K 23	25 (.984)	8.2 (.323)	10 (.394)	1.0 (.039)	29 (1.142)	5.0 (.197)
CVQ 510 K 10	12.5 (.492)	8.2 (.323)	7.5 (.295)	0.8 (.031)	16 (.630)	5.1 (.201)
CVQ 510 K 14	16.5 (.650)	8.2 (.323)	7.5 (.295)	0.8 (.031)	21 (.827)	5.1 (.201)
CVQ 510 K 20	22.5 (.886)	8.7 (.343)	10 (.394)	1.0 (.039)	27 (1.063)	5.3 (.209)
CVQ 510 K 23	25 (.984)	8.7 (.343)	10 (.394)	1.0 (.039)	29 (1.142)	5.3 (.209)
CVQ 550 K 10	12.5 (.492)	8.8 (.346)	7.5 (.295)	0.8 (.031)	16 (.630)	5.6 (.220)
CVQ 550 K 14	16.5 (.650)	8.8 (.346)	7.5 (.295)	0.8 (.031)	21 (.827)	5.6 (.220)
CVQ 550 K 20	22.5 (.886)	9.2 (.362)	10 (.394)	1.0 (.039)	27 (1.063)	5.8 (.228)
CVQ 550 K 23	25 (.984)	9.2 (.362)	10 (.394)	1.0 (.039)	29 (1.142)	5.8 (.228)

DIMENSIONS:  $\frac{\text{MM}}{\text{(INCHES)}}$

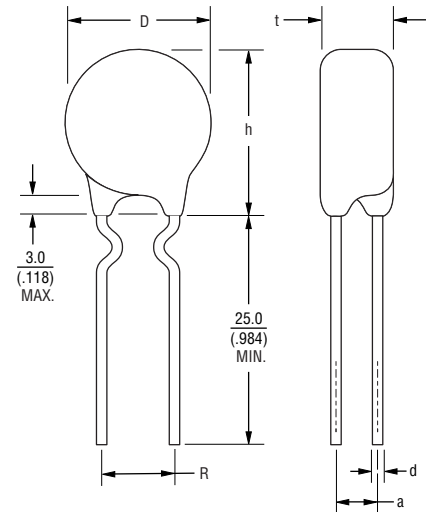
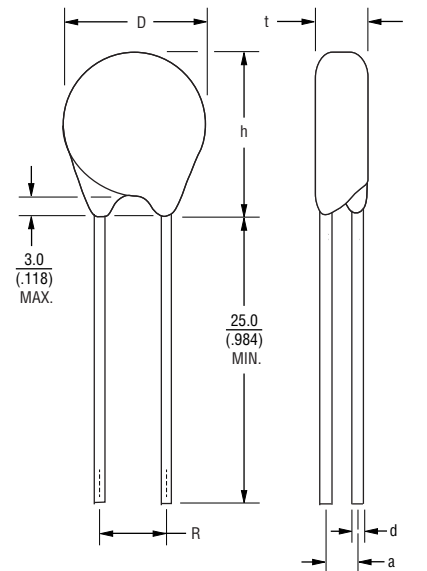

Specifications are subject to change without notice.

Users should verify actual device performance in their specific applications.

The products described herein and this document are subject to specific legal disclaimers as set forth on the last page of this document, and at [www.bourns.com/docs/legal/disclaimer.pdf](http://www.bourns.com/docs/legal/disclaimer.pdf).

# CVQ Series – Extended Medium Voltage Disc Varistors



## How to Order

CVQ150K20RL1yy

Series Designator \_\_\_\_\_  
 CVQ = CVQ Series

Max. Continuous Operating Voltage ( $V_{rms}$ ) \_\_\_\_\_  
 $V_n$  Tolerance \_\_\_\_\_  
 K =  $\pm 10\%$

Model Size \_\_\_\_\_  
 7 = 7 mm      20 = 20 mm  
 10 = 10 mm    23 = 23 mm  
 14 = 14 mm

Packaging \_\_\_\_\_  
 R = Reel\*  
 B = Bulk  
 A = Ammo Pack (Available only upon special request)\*  
 \*Reel and Ammo Pack options not available for Model Sizes 20 and 23.

Lead Style \_\_\_\_\_  
 L1 = Straight Leads  
 L5 = Crimped Leads

Special Parameters \_\_\_\_\_  
 yy = Unique two digit suffix is assigned to each customer requesting special parameters.  
 Please contact Bourns for more information.

## Instructions for Creating Orderable Part Number:

- 1) Start with base part number in characteristics table  
 (example: CVQ150K20).
- 2) Add Packaging: R  
 (example part number becomes CVQ150K20R).
- 3) Add Lead Style: L1  
 (example part number becomes CVQ150K20RL1).
- 4) Part number can have no spaces or lower case letters.

## Pulse Rating Curves - Protection level with worst-case condition in the tolerance region

### Model Size 7 - (CVQ 60 ~ CVQ 300)

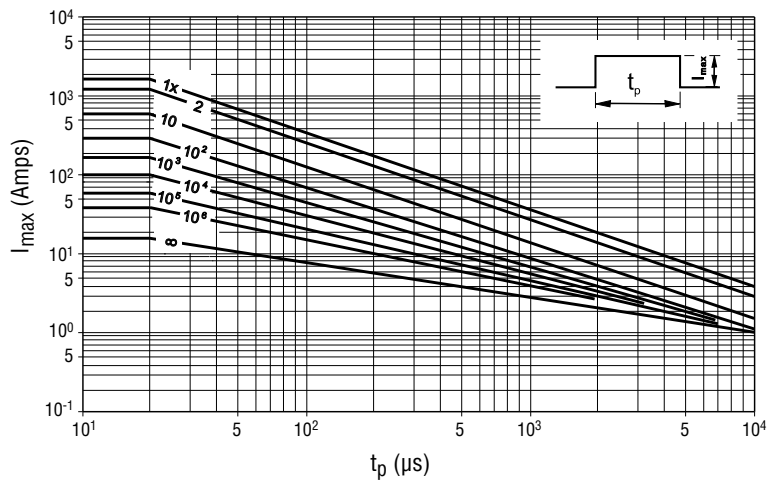
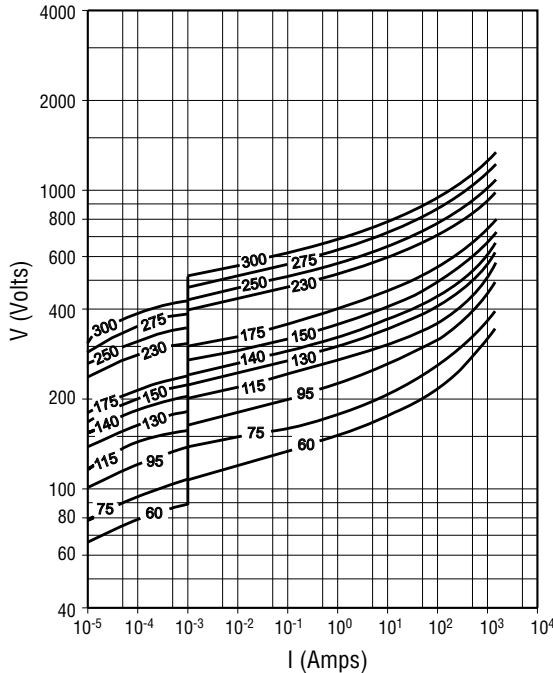

Specifications are subject to change without notice.  
 Users should verify actual device performance in their specific applications.  
 The products described herein and this document are subject to specific legal disclaimers as set forth on the last page of this document, and at [www.bourns.com/docs/legal/disclaimer.pdf](http://www.bourns.com/docs/legal/disclaimer.pdf).

# CVQ Series – Extended Medium Voltage Disc Varistors

**BOURNS®**

**Pulse Rating Curves (Continued)** - Protection level with worst-case condition in the tolerance region

## Model Size 10 - (CVQ 60 ~ CVQ 550)

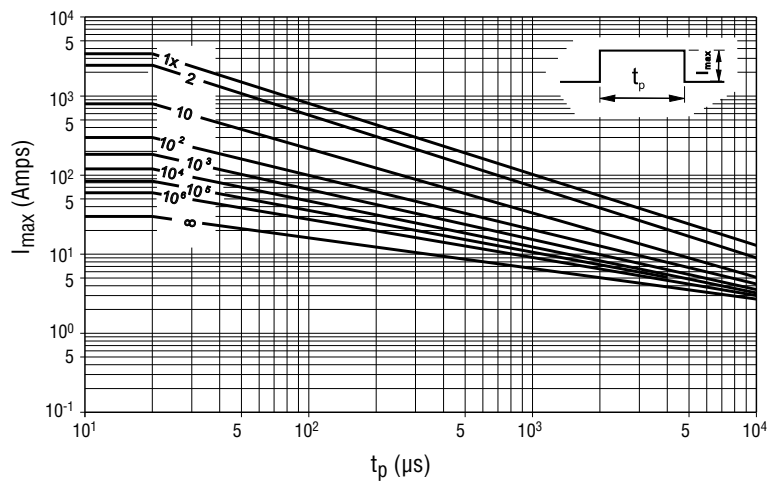
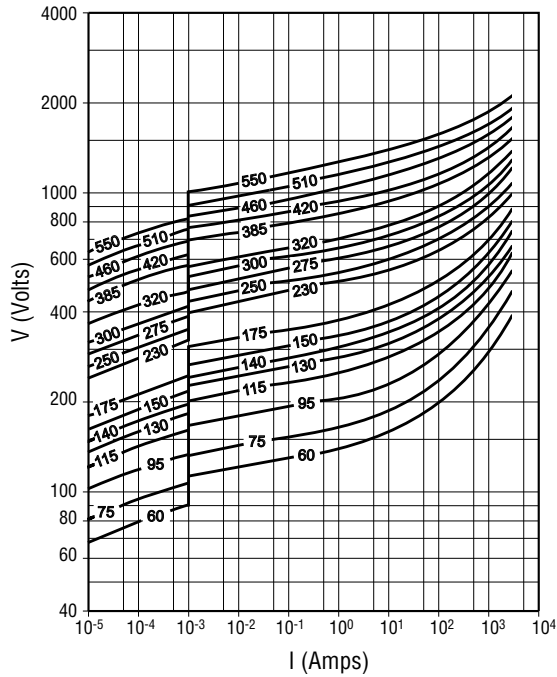

## Model Size 14 - (CVQ 60 ~ CVQ 550)

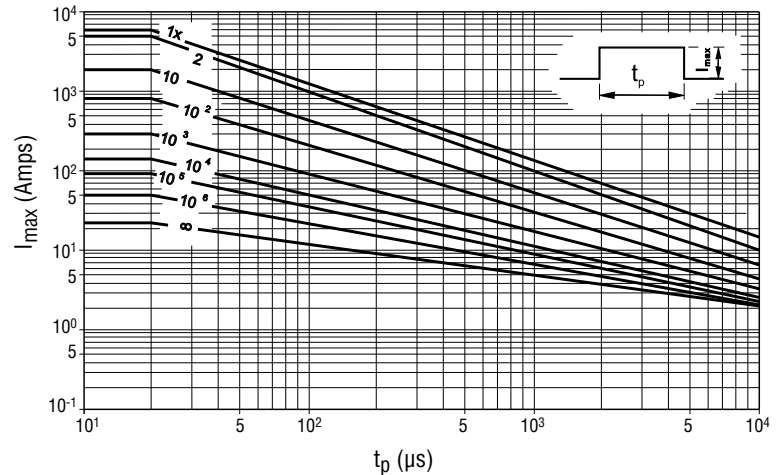
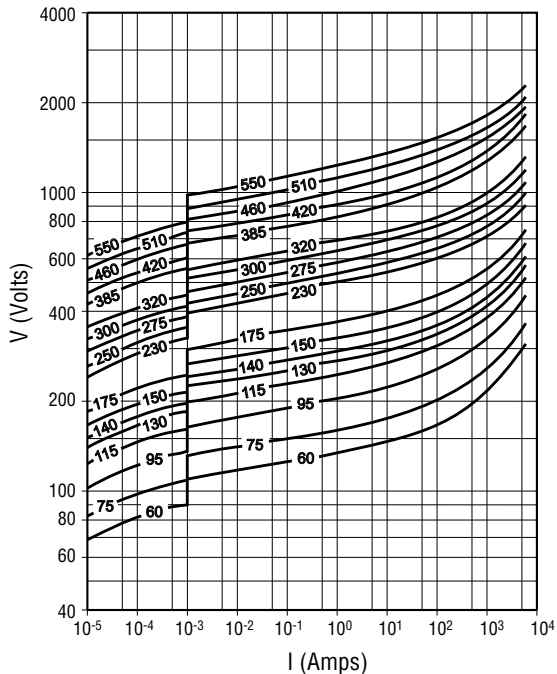

Specifications are subject to change without notice.

Users should verify actual device performance in their specific applications.

The products described herein and this document are subject to specific legal disclaimers as set forth on the last page of this document, and at [www.bourns.com/docs/legal/disclaimer.pdf](http://www.bourns.com/docs/legal/disclaimer.pdf).

# CVQ Series – Extended Medium Voltage Disc Varistors

**BOURNS®**

**Pulse Rating Curves (Continued)** - Protection level with worst-case condition in the tolerance region

## Model Size 20 - (CVQ 60 ~ CVQ 550)

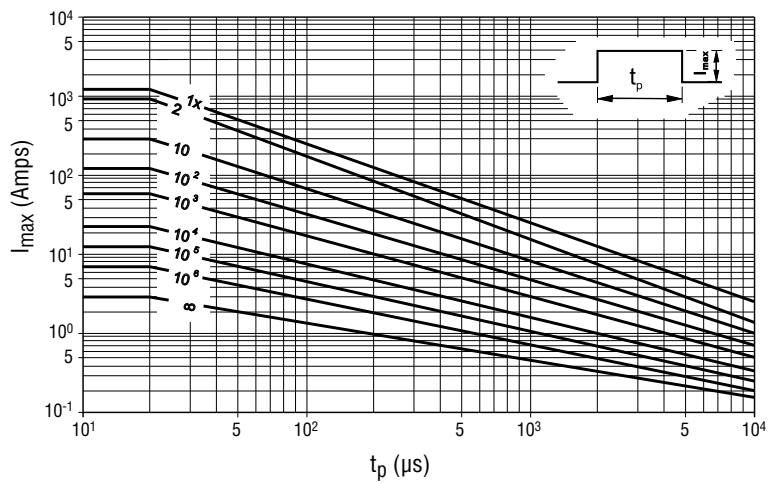
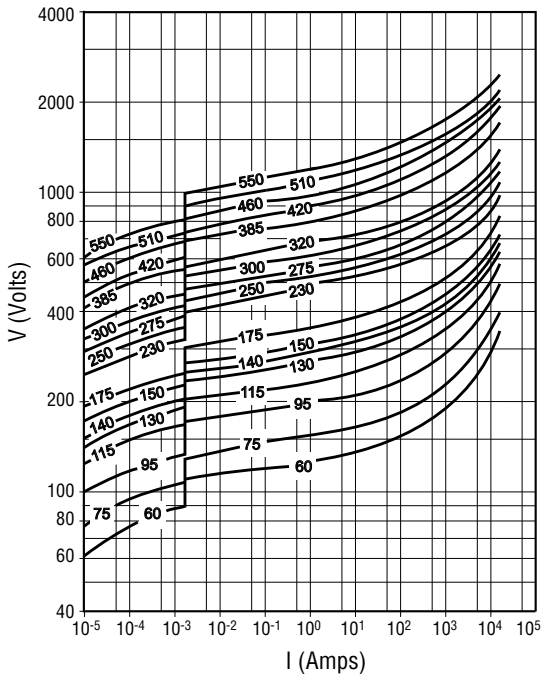

## Model Size 23 - (CVQ 60 ~ CVQ 550)

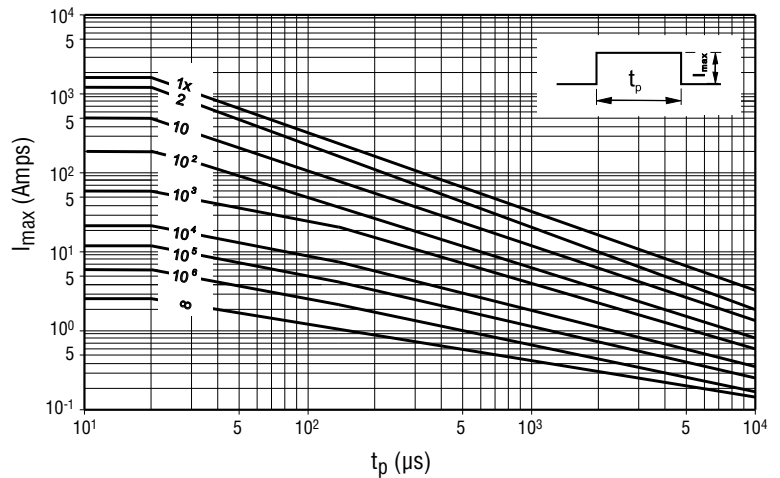
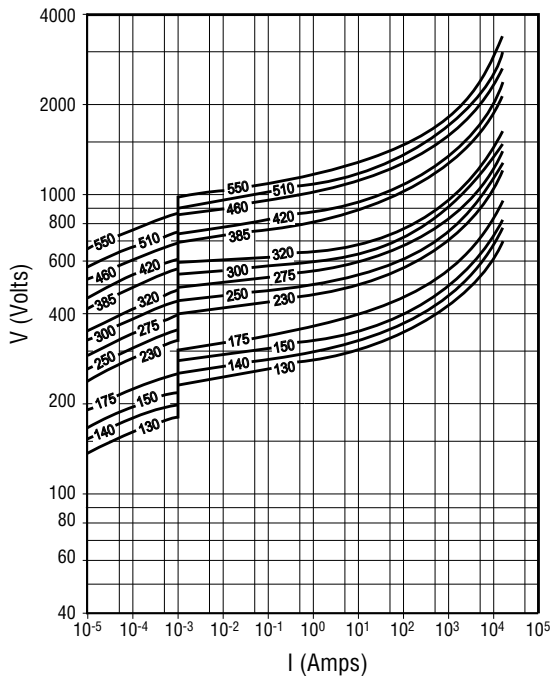

Specifications are subject to change without notice.

Users should verify actual device performance in their specific applications.

The products described herein and this document are subject to specific legal disclaimers as set forth on the last page of this document, and at [www.bourns.com/docs/legal/disclaimer.pdf](http://www.bourns.com/docs/legal/disclaimer.pdf).

# CVQ Series – Extended Medium Voltage Disc Varistors

**BOURNS®**

## Packaging Specifications - Tape

Conforms to IES Publication 286-2 Ed. 3: 2008-03

### Dimension R = 5 mm

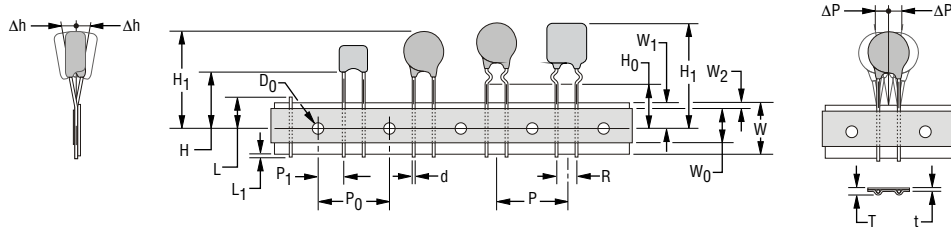

Dimensions on Next Page

### Dimension R = 7.5 mm & 10 mm

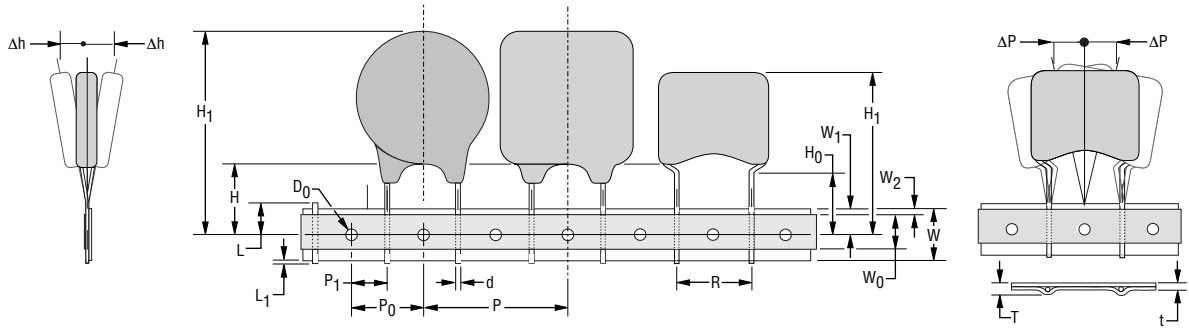

Dimensions on Next Page

### Reel

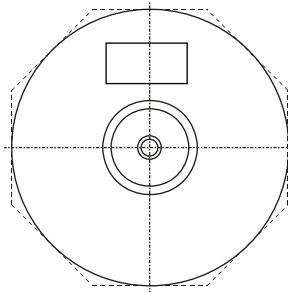
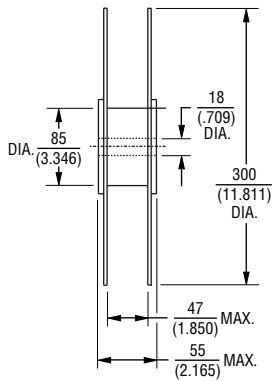

DIMENSIONS:  $\frac{\text{MM}}{\text{(INCHES)}}$

### Ammo Pack (Available upon Special Request)

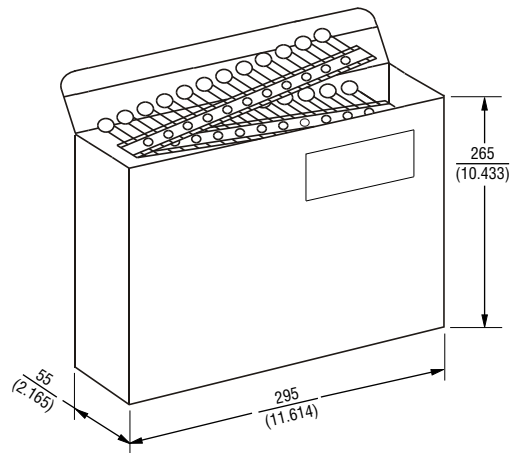

Specifications are subject to change without notice.

Users should verify actual device performance in their specific applications.

The products described herein and this document are subject to specific legal disclaimers as set forth on the last page of this document, and at [www.bourns.com/docs/legal/disclaimer.pdf](http://www.bourns.com/docs/legal/disclaimer.pdf).

# CVQ Series – Extended Medium Voltage Disc Varistors



## Packaging Specifications - Tape (Continued)

Symbol	Parameter	Model Size				
		7	10	14	20	23
W	Carrier tape width	$\frac{18 + 1.0/-0.5}{(.709 + .039/- .020)}$				
W <sub>0</sub>	Hold down tape width	$\frac{5}{(.197)}$ MIN.				
W <sub>1</sub>	Sprocket hole position	$\frac{9 + 0.75/-0.5}{(.354 + .030/- .020)}$				
W <sub>2</sub>	Distance between the upper edges of the carrier tape and hold down tape	$\frac{3}{(.118)}$ MAX.				
T	Total tape thickness	$\frac{1.5}{(.059)}$ MAX.	$\frac{1.7}{(.067)}$ MAX.	$\frac{1.9}{(.075)}$ MAX.		
t	Tape thickness	$\frac{0.9}{(.035)}$ MAX.				
P	Pitch of component	$\frac{12.7 \pm 1.0}{(.500 \pm .039)}$		$\frac{25.4 \pm 1.0}{(1.000 \pm .039)}$		
P <sub>0</sub>	Feed hole pitch	$\frac{12.7 \pm 0.3}{(.500 \pm .012)}$				
P <sub>1</sub>	Feed hole center to pitch	$\frac{3.85 \pm 0.7}{(.152 \pm .028)}$	$\frac{8.95 \pm 0.7}{(.352 \pm .028)}$	$\frac{7.7 \pm 0.7}{(.303 \pm .028)}$		
R	Lead spacing	$\frac{5 + 0.5/-0.2}{(.197 + .020/- .008)}$	$\frac{7.5 + 0.5/-0.2}{(.295 + .020/- .008)}$	$\frac{10 + 0.5/-0.2}{(.394 + .020/- .008)}$		
ΔP	Component alignment	$\frac{\pm 1.3}{(\pm .051)}$ MAX.				
Δh	Component alignment	$\frac{\pm 2}{(\pm .079)}$ MAX.				
d	Wire diameter	$\frac{0.6}{(.024)}$ MAX.	$\frac{0.8}{(.031)}$ MAX.	$\frac{1}{(.039)}$ MAX.		
D <sub>0</sub>	Feed hold diameter	$\frac{4 \pm 0.2}{(.157 \pm .008)}$				
H	Height from tape center to component base	$\frac{18 + 2.0/-0.0}{(.709 + .079/- .000)}$				
H <sub>0</sub>	Seating plane height	$\frac{16 \pm 0.5}{(.630 \pm .020)}$				
H <sub>1</sub>	Component height	$\frac{32.2}{(1.268)}$ MAX.	$\frac{46.5}{(1.831)}$ MAX.			
L	Protrusion - cut out	$\frac{11}{(.433)}$ MAX.				
L <sub>1</sub>	Protrusion - cut off	$\frac{0.5}{(.020)}$ MAX.				

DIMENSIONS:  $\frac{\text{MM}}{(\text{INCHES})}$

Specifications are subject to change without notice.

Users should verify actual device performance in their specific applications.

The products described herein and this document are subject to specific legal disclaimers as set forth on the last page of this document, and at [www.bourns.com/docs/legal/disclaimer.pdf](http://www.bourns.com/docs/legal/disclaimer.pdf).

# CVQ Series – Extended Medium Voltage Disc Varistors



## Packaging Quantities - Bulk

Voltage	Model Size				
	7	10	14	20	23
60	1500	600	400	300	
75	1500	600	400	300	
95	1000	600	400	300	
115	1000	500	400	300	
130	1000	500	400	300	250
140	1000	500	400	300	250
150	1000	500	400	300	250
175	1000	500	400	300	250
230	1000	500	300	200	200
250	1000	500	300	200	200
275	1000	500	300	200	200
300	1000	500	300	200	200
320		500	300	200	200
385		400	300	200	200
420		400	300	200	150
460		400	300	200	150
510		400	300	200	150
550		400	300	200	150

## Packaging Quantities - Reel

Voltage	Model Size				
	7	10	14	20	23
60	1500	1300	700		
75	1500	1300	700		
95	1000	1300	600		
115	1000	1000	600		
130	1000	1000	600		
140	1000	1000	600		
150	1000	1000	600		
175	1000	1000	500		
230	1000	1000	500		
250	1000	800	400		
275	1000	800	400		
300	1000	800	400		
320		800	400		
385		700	400		
420		700	300		
460		600	300		
510		600	300		
550		600	300		

Specifications are subject to change without notice.

Users should verify actual device performance in their specific applications.

The products described herein and this document are subject to specific legal disclaimers as set forth on the last page of this document, and at [www.bourns.com/docs/legal/disclaimer.pdf](http://www.bourns.com/docs/legal/disclaimer.pdf).



# CVQ Series – Extended Medium Voltage Disc Varistors



## Reliability Testing Procedures

Varistor test procedures comply with CECC 42200, IEC 1051-1/2 (and AEC-Q200, if applicable). Test results are available upon customer request. Special tests can be performed upon customer request.

Reliability Parameter	Test	Tested According to	Condition to be Satisfied after Testing
<b>AC/DC Bias Reliability</b>	AC/DC Life Test	CECC 42200, Test 4.20 or IEC 1051-1, Test 4.20, AEC-Q200 Test 8 - 1000 h at UCT	$ \delta V_N (1 \text{ mA})  < 10 \%$
<b>Pulse Current Capability</b>	$I_{\text{max}} 8/20 \mu\text{s}$	CECC 42200, Test C 2.1 or IEC 1051-1, Test 4.5 10 pulses in the same direction at 2 pulses per minute at maximum peak current for 10 pulses	$ \delta V_N (1 \text{ mA})  < 10 \%$ no visible damage
<b>Pulse Energy Capability</b>	$W_{\text{max}} 10/1000 \mu\text{s}$	CECC 42200, Test C 2.1 or IEC 1051-1, Test 4.5 10 pulses in the same direction at 1 pulse every 2 minutes at maximum peak current for 10 pulses	$ \delta V_N (1 \text{ mA})  < 10 \%$ no visible damage
<b>WLD Capability</b>	WLD x 10	ISO 7637, Test pulse 5, 10 pulses at rate of 1 per minute	$ \delta V_N (1 \text{ mA})  < 15 \%$ no visible damage
<b>V<sub>jump</sub> Capability</b>	$V_{\text{jump}} 5 \text{ min.}$	Increase of supply voltage to $V \geq V_{\text{jump}}$ for 1 minute	$ \delta V_N (1 \text{ mA})  < 15 \%$ no visible damage
<b>Environmental and Storage Reliability</b>	Climatic Sequence	CECC 42200, Test 4.16 or IEC 1051-1, Test 4.17 a) Dry heat, 16h, UCT, Test Ba, IEC 68-2-2 b) Damp heat, cyclic, the first cycle: 55 °C, 93 % RH, 24 h, Test Db 68-2-4 c) Cold, LCT, 2 h, Test Aa, IEC 68-2-1 d) Damp heat cyclic, remaining 5 cycles: 55 °C, 93 % RH, 24 h/cycle, Test Bd, IEC 68-2-30	$ \delta V_N (1 \text{ mA})  < 10 \%$
	Thermal Shock	CECC 42200, Test 4.12, Test Na, IEC 68-2-14, AEC-Q200 Test 16, 5	$ \delta V_N (1 \text{ mA})  < 10 \%$ no visible damage
	Steady State Damp Heat	CECC 42200, Test 4.17, Test Ca, IEC 68-2-3, AEC-Q200 Test 6, 56 days, 40 °C, 93 % RH, AEC-Q200 Test 7: Bias, Rh, T all at 85.	$ \delta V_N (1 \text{ mA})  < 10 \%$
	Storage Test	IEC 68-2-2, Test Ba, AEC-Q200 Test 3, 1000 h at maximum storage temperature	$ \delta V_N (1 \text{ mA})  < 5 \%$

Continued on Next Page

Specifications are subject to change without notice.

Users should verify actual device performance in their specific applications.

The products described herein and this document are subject to specific legal disclaimers as set forth on the last page of this document, and at [www.bourns.com/docs/legal/disclaimer.pdf](http://www.bourns.com/docs/legal/disclaimer.pdf).

## Reliability Testing Procedures (Continued)

Reliability Parameter	Test	Tested According to	Condition to be Satisfied after Testing
<b>Mechanical Reliability</b>	Solderability	CECC 42200, Test 4.10.1, Test Ta, IEC 68-2-20 solder bath and reflow method	Solderable at shipment and after 2 years of storage, criteria: >95% must be covered by solder for reflow meniscus
	Resistance to Soldering Heat	CECC 42200, Test 4.10.2, Test Tb, IEC 68-2-20 solder bath nad reflow method	$ ΔV_n (1 mA)  < 5 %$
	Terminal Strength	JIS-C-6429, App. 1, 18N for 60 sec. - same for AEC-Q200 Test 22	No visual damage
	Board Flex	JIS-C-6429, App. 2, 2 mm min. AEC-Q200 test 21 - Board flex: 2 mm flex min.	$ ΔV_n (1 mA)  < 2 %$ No visible damage
	Vibration	CECC 42200, Test 4.15, Test Fc, IEC 68-2-6, AEC-Q200 Test 14 Frequency range 10 to 55 Hz (AEC: 10-2000 Hz) Amplitude 0.75 m/s <sup>2</sup> or 98 m/s <sup>2</sup> (AEC: 5 g for 20 minutes) Total duration 6 h (3x2 h) (AEC: 12 cycles each of 3 directions) Waveshape - half sine	$ ΔV_n (1 mA)  < 2 %$ No visible damage
	Mechanical Shock	CECC 42200, Test 4.14, Test Ea, IEC 68-2-27, AEC-Q200 Test 13. Acceleration = 490 m/s <sup>2</sup> (AEC: MIL-STD-202-Method 213), Pulse duration = 11 ms, Waveshape - half sine; Number of shocks = 3x6	$ ΔV_n (1 mA)  < 10 %$ No visible damage
<b>Electrical Transient Conduction</b>	ISO-7637-1 Pulses	AEC-Q200 Test 30: Test pulses 1 to 3. Also other pulses - freestyle.	$ ΔV_n (1 mA)  < 10 %$ No visible damage

Specifications are subject to change without notice.

Users should verify actual device performance in their specific applications.

The products described herein and this document are subject to specific legal disclaimers as set forth on the last page of this document, and at [www.bourns.com/docs/legal/disclaimer.pdf](http://www.bourns.com/docs/legal/disclaimer.pdf).

# CVQ Series – Extended Medium Voltage Disc Varistors

**BOURNS®**

## Terminology

Term	Symbol	Definition
Rated AC Voltage .....	$V_{rms}$	Maximum continuous sinusoidal AC voltage (<5 % total harmonic distortion) which may be applied to the component under continuous operation conditions at +25 °C
Rated DC Voltage.....	$V_{dc}$	Maximum continuous DC voltage (<5 % ripple) which may be applied to the component under continuous operating conditions at +25 °C
Supply Voltage.....	$V$	The voltage by which the system is designated and to which certain operating characteristics of the system are referred; $V_{rms} = 1.1 \times V$
Leakage Current.....	$I_{dc}$	The current passing through the varistor at $V_{dc}$ and at +25 ° or at any other specified temperature
Varistor Voltage .....	$V_n$	Voltage across the varistor measured at a given reference current ( $I_n$ )
Reference Current.....	$I_n$	Reference current = 1 mA DC
Clamping Voltage .....	$V_c$	The peak voltage developed across the varistor under standard atmospheric conditions, when passing an 8/20 $\mu s$ class current pulse
Protection Level		
Class Current.....	$I_c$	A peak value of current which is 1/10 of the maximum peak current for 100 pulses at two per minute for the 8/20 $\mu s$ pulse
Voltage Clamping Ratio.....	$V_c/V_{app}$	A figure of merit measure of the varistor clamping effectiveness as defined by the symbols $V_c/V_{app}$ , where ( $V_{app} = V_{rms}$ or $V_{dc}$ )
Jump Start Transient .....	$V_{jump}$	The jump start transient results from the temporary application of an overvoltage in excess of the rated battery voltage. The circuit power supply may be subjected to a temporary overvoltage condition due to the voltage regulation failing or it may be deliberately generated when it becomes necessary to boost start the car.
Rated Single Pulse .....	$W_{max}$	Energy which may be dissipated for a single 10/1000 $\mu s$ pulse of a maximum rated current, with rated AC voltage or rated DC voltage also applied, without causing device failure
Transient Energy		
Load Dump Transient .....	WLD	Load Dump is a transient which occurs in automotive environments. It is an exponentially decaying positive voltage which occurs in the event of a battery disconnect while the alternator is still generating charging current with other loads remaining on the alternator circuit at the time of battery disconnect.
Rated Peak Single Pulse.....	$I_{max}$	Maximum peak current which may be applied for a single 8/20 $\mu s$ pulse, with rated line voltage also applied, without causing device failure
Transient Current		
Rated Transient Average .....	$P$	Maximum average power which may be dissipated due to a group of pulses occurring within a specified isolated time period, without causing device failure at 25 °C
Power Dissipation		
Capacitance.....	$C$	Capacitance between two terminals of the varistor measured @ 1 kHz
Non-linearity Exponent .....	$\alpha$	A measure of varistor nonlinearity between two given operating currents, $I_n$ and $I_1$ as described by $I = k V \exp(a)$ , where: <ul style="list-style-type: none"> <li>- <math>k</math> is a device constant,</li> <li>- <math>I_1 &lt; I &lt; I_n</math> and</li> <li>- <math>a \log(I_1/I_n) / \log(V_1/V_n) = 1 / \log(V_1/V_n)</math>, where:</li> <li>- <math>I_r</math> is reference current (1 mA) and <math>V_n</math> is varistor voltage</li> <li>- <math>I_1 = 10 I_n</math>, <math>V_1</math> is the voltage measured at <math>I_1</math></li> </ul>
Response Time.....	$t_r$	The time lag between application of a surge and varistor's "turn-on" conduction action
Varistor Voltage Temperature .....	TC	$(V_n @ 85 °C - V_n @ 25 °C) / (V_n @ 25 °C) \times 60 °C \times 100$
Coefficient		
Insulation Resistance .....	IR	Minimum resistance between shorted terminals and varistor surface
Isolation Voltage .....		The maximum peak voltage which may be applied under continuous operating conditions between the varistor terminations and any conducting mounting surface
Operating Temperature .....		The range of ambient temperature for which the varistor is designed to operate continuously as defined by the temperature limits of its climatic category
Climatic Category .....	LCT/UCT/DHD	LCT & UCT = Lower and Upper Category Temperature - the minimum and maximum ambient temperatures for which a varistor has been designed to operate continuously. DHD = Dump Heat Test Duration
Storage Temperature.....		Storage temperature range without voltage applied
Current/Energy Derating.....		Derating of maximum values when operated above UCT

REV. F 05/21

Specifications are subject to change without notice.

Users should verify actual device performance in their specific applications.

The products described herein and this document are subject to specific legal disclaimers as set forth on the last page of this document, and at [www.bourns.com/docs/legal/disclaimer.pdf](http://www.bourns.com/docs/legal/disclaimer.pdf).

This legal disclaimer applies to purchasers and users of Bourns® products manufactured by or on behalf of Bourns, Inc. and its affiliates (collectively, "Bourns").

Unless otherwise expressly indicated in writing, Bourns® products and data sheets relating thereto are subject to change without notice. Users should check for and obtain the latest relevant information and verify that such information is current and complete before placing orders for Bourns® products.

The characteristics and parameters of a Bourns® product set forth in its data sheet are based on laboratory conditions, and statements regarding the suitability of products for certain "typical" applications are based on Bourns' knowledge of typical requirements in generic applications. Bourns assumes that "typical" applications include failsafe/backup features to address critical risks to users and are designed to allow rework of Bourns® product to avoid scrap of a device solely due to malfunctioning Bourns® product. The characteristics and parameters of a Bourns® product in a user application may vary from the data sheet characteristics and parameters due to (i) the combination of the Bourns® product with other components in the user's application, or (ii) the environment of the user application itself. The characteristics and parameters of a Bourns® product also can and do vary in different applications and actual performance may vary over time. Thus, users should always verify the actual performance of the Bourns® product in their specific devices and applications and make their own independent judgments regarding the suitability of Bourns® product and the amount of additional test margin to design into their device or application to compensate for differences between laboratory and real-world conditions.

Unless Bourns has explicitly designated an individual Bourns® product as meeting the requirements of a particular industry standard (e.g., IATF 16949) or a particular qualification (e.g., UL listed or recognized), Bourns is not responsible for any failure of an individual Bourns® product to meet the requirements of such industry standard or particular qualification even if such industry standard or qualification is a "state of art". Users of Bourns® products are responsible for ensuring compliance with safety-related requirements and standards applicable to their devices or applications.

Bourns® products are not recommended, authorized or intended for use in applications where failure or malfunction may result in personal injury, death, or severe property or environmental damage, such as without limitation nuclear, life-critical medical and certain automotive and aviation applications. Except as set forth in the bullet points below or unless expressly and specifically approved in writing on a case-by-case basis by an authorized Bourns' representative, use of any Bourns® products in such unauthorized high-risk applications is at the user's sole risk.

- Bourns considers implantable/invasive devices and devices/procedures designed as life-supporting or life-sustaining by the U.S. Food and Drug Administration or equivalent organizations outside of the United States as "life-critical" medical applications. Bourns expressly identifies those Bourns® standard products that are suitable for use in typical medical applications that are not life-critical in its publication entitled "Bourns Medical Grade Component Guide."
- Bourns expressly identifies those Bourns® standard products that are suitable for use in typical automotive applications associated with any Automate Safety Integrity Level (ASIL) in its publication entitled "Bourns Automotive Grade Component Guide." Bourns' designation of Bourns® product as compliant with the AEC-Q standard does not by itself mean that Bourns has approved such product for use in an automotive application.
- Bourns expressly identifies Bourns® standard products that are suitable for use in the typical aviation applications/systems requiring System Design Assurance Level (RTCA DO-254 DAL) of C, D or E in its publication entitled "Bourns Civilian Aerospace/Aviation Grade Component Guide." Bourns does not test its products for compliance with United States Federal Aviation Administration standards or any other generally equivalent governmental organization standard applicable to products designed or manufactured for use in aviation applications. Use of Bourns® standard components in aviation applications associated with RTCA DO-254 DAL A or B without proper approval noted above shall be at the user's sole risk.
- Bourns will review and authorize on a case-by-case basis the use of Bourns® standard products which are at least AEC-Q compliant in space-related civil applications (rockets, satellites) with a negotiated cross-waiver and indemnity agreement.

The use and level of testing applicable to Bourns® custom products shall be negotiated on a case-by-case basis by Bourns and the user for which such Bourns® custom products are specially designed. Absent a written agreement between Bourns and the user regarding the use and level of such testing, the above provisions applicable to Bourns® standard products shall also apply to such Bourns® custom products.

Use of Bourns® products or Bourns' technology in military/defense applications must be reviewed with Bourns for compliance with applicable export control laws and embargoes. Users shall not sell, transfer, export or re-export (which includes transfers within a country) any Bourns® products or technology or technical data for use in activities which involve the design, development, production, use or stockpiling of nuclear, chemical or biological weapons or missiles, nor shall they use Bourns® products or technology or technical data in any facility which engages in activities relating to such devices. Further, Bourns® products and Bourns' technology and technical data may not under any circumstance be exported or re-exported to countries subject to international sanctions or embargoes. Bourns® products and technology may not, without prior authorization from Bourns and/or the Government of a country where such product/technology is designed and/or manufactured, be resold, transferred, or re-exported (including within the same country) to any party not eligible to receive commodities, software, and technical data originating in such country.

To the maximum extent permitted by applicable law, Bourns disclaims (i) any and all liability for special, punitive, consequential, incidental or indirect damages or lost revenues or lost profits, and (ii) any and all implied warranties (those not based on parameters specified in Bourns' data sheets and/or specifications), including implied warranties of fitness for particular purpose, non-infringement and merchantability.

For your convenience, copies of this Legal Disclaimer Notice with German, Spanish, Japanese, Traditional Chinese and Simplified Chinese bilingual versions are available at:

Web Page: <https://www.bourns.com/legal/disclaimers-terms-and-policies>

PDF: <https://www.bourns.com/docs/Legal/disclaimer.pdf>