

BEST of the TRIMMER PRIMERS

HIGHLIGHTS FROM
TRIMMER PRIMER I, II, III & IV

INCLUDING
INFO ON NEW
OP AMP OFFSET
AND SMD
TRIMMERS

BOURNS TRIMPOT



TABLE OF CONTENTS

LESSON 1 - THE BASICS:

TYPICAL USES

TYPES OF TRIMMING POTENTIOMETERS

LEAD SCREW

WORM GEAR

SINGLE-TURN

SURFACE MOUNT

CENTER TAP

SINGLE OR MULTI-TURN?

CERMET VS. WIREWOUND

HOW TO SELECT THE RIGHT TRIMMING

POTENTIOMETER

LESSON 2 - TRIMMERS FOR SPECIAL REQUIREMENTS:

CENTER -TAP TRIMMING POTENTIOMETERS

COARSE/FINE ADJUSTMENT

MULTI- TRIMMER PACKAGES

NON-LINEAR

SELECTING A TRIMMER THAT SAVES MONEY

LESSON 3 - THE ADVANCED COURSE:

VOLTAGE DIVIDER MODE

RHEOSTAT MODE

LINEARITY, ADJUSTABILITY, RESOLUTION

END ZONE CHARACTERISTICS

POWER AND CURRENT RATIOS

RESISTANCE VALUES AND TOLERANCES

DRY CIRCUIT CONDITIONS

MORE CIRCUIT APPLICATIONS

OP AMP OFFSET ADJUSTMENT

OSCILLATOR CIRCUITS

LESSON 4—THE HOSTILE ENVIRONMENT CALLED PRODUCTION:

SOLDERING

BOARD WASHING

A FINAL CHECKLIST

SEALS

THE MECHANICAL MENACES

FINAL INSPECTION

OPERATING ENVIRONMENT

LESSON 5— A LOOK BELOW THE SURFACE OF SMT:

THE POSSIBILITIES OF SMT

NO PAIN, NO GAIN

PROCESSES: THE SCHOOL OF HARD KNOCKS

HOW TO PUT THE RIGHT INSERTION EQUIPMENT

INTO YOUR MANUFACTURING PLAN.

PACKAGING: A MATCH FOR YOUR PLACEMENT METHOD.

SOLDERING— WHERE THE SMT ISSUE REALLY HEATS UP.

WHERE WE STAND ON SMT

THE PRODUCTS

POST GRADUATE STUDY

INTRODUCTION TO THE BEST OF TRIMMER PRIMERS

LITTLE DID WE KNOW WHEN TRIMMER PRIMER I WAS BEING CREATED THAT IT WOULD PROVE SO POPULAR. IN FACT, THE TITLE OF TRIMMER PRIMER I WAS “EVERYTHING YOU NEVER WANTED TO KNOW ABOUT TRIMMING CIRCUITS”. NOW THAT’S HUMBLE!

BUT JUST AS WE SUSPECTED, CIRCUIT DESIGNERS REALLY DID WANT MORE INFORMATION AND TRIMMER PRIMER’S FIRST PRINTING “SOLD OUT” QUICKLY AND EVENTUALLY WENT INTO SEVERAL PRINTINGS. THAT WAS JUST THE BEGINNING. NEXT CAME TRIMMER PRIMER II (“JUST WHEN YOU THOUGHT YOU KNEW EVERYTHING YOU NEVER WANTED TO KNOW ABOUT TRIMMING CIRCUITS”), FOLLOWED BY TRIMMER PRIMER III (“HOW TO KNOW TRIMMERS IN IC APPLICATIONS BACKWARDS AND FORWARDS”) AND MOST RECENTLY—TRIMMER PRIMER IV (“A LOOK BELOW THE SURFACE OF SMT”). WITH SOME OF THE PRIMERS “OUT OF PRINT” AND WITH THE SUPPLY OF OTHERS RUNNING LOW, WHAT COULD BE BETTER FOR TRIMMING POTENTIOMETER USERS EVERYWHERE— ESPECIALLY FOR THOSE WHO HAVE MISSED ONE OR MORE OF THE SERIES— THAN A “GREATEST HITS” ANTHOLOGY?

HERE IT IS, “THE BEST OF TRIMMER PRIMER”!!

THIS SPECIAL ISSUE COMBINES ALL THE CONTENT OF THE TRIMMER PRIMERS BEFORE IT—COVERING ALL THE IMPORTANT AREAS, PROVIDING ALL THE DETAILS BUT ELIMINATING DUPLICATION. THERE'S ALSO SOME TOTALLY NEW INFORMATION—HIGHLIGHTED IN THE INDEX—ON A NEW SMD FROM BOURNS AND ON THE NEW OT1 TRIMMING POTENTIOMETER DESIGNED SPECIFICALLY FOR TRIMMING OP-AMPS.

ONE FINAL THOUGHT. WE WANT TO THANK YOU FOR YOUR CONTINUED INTEREST IN BOURNS TRIMMING POTENTIOMETERS AND IN THE TRIMMER PRIMER SERIES. THERE'S ALWAYS MORE THAT YOU NEVER WANTED TO KNOW ABOUT TRIMMING CIRCUITS, AND WE'LL KEEP PRINTING IT.

LESSON 1- THE BASICS

A TRIMMING POTENTIOMETER (AKA TRIMMER) IS MOST OFTEN INCLUDED IN A CIRCUIT FOR EASY "TWEAKING"- TO CORRECT FOR VARIATIONS IN OTHER CIRCUIT COMPONENTS, OR FOR CHANGES DUE TO AGING.

IT'S DESIGNED SO YOU CAN VARY ITS RESISTANCE, OR USE IT AS A VOLTAGE DIVIDER FOR ADJUSTING VOLTAGE.

ADJUSTMENT FOR CIRCUIT VOLTAGES- (VOLTAGE DIVIDER MODE)

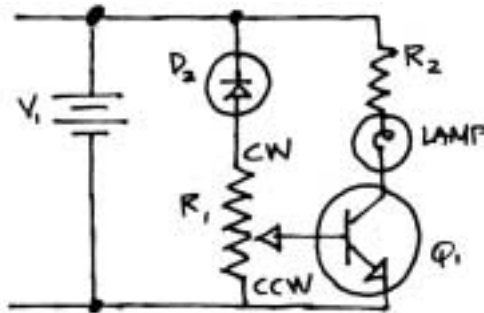

CURRENT ADJUSTMENT- (RHEOSTAT MODE)

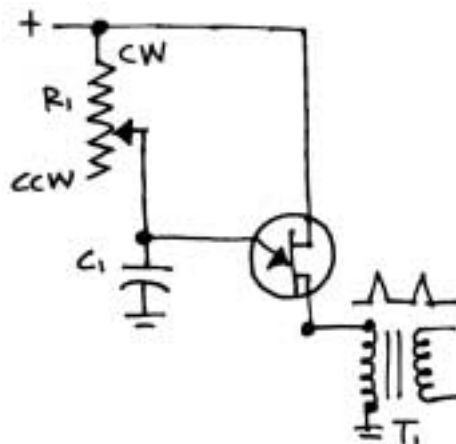

ENGINEERS WITH IMAGINATION HAVE USED TRIMMERS TO SOLVE INNUMERABLE DESIGN PROBLEMS. HERE ARE A FEW EXAMPLES THAT SUGGEST THE WIDE RANGE OF POSSIBILITIES:

TYPE OF CIRCUIT	EXAMPLES OF USE
POWER SUPPLIES	<ul style="list-style-type: none"> • OUTPUT VOLTAGE ADJUSTMENT. • CURRENT LIMIT ADJUSTMENT.
OP AMP	<ul style="list-style-type: none"> • OFFSET ADJUSTMENT. • GAIN ADJUSTMENT.
DIGITAL CIRCUITS*	<ul style="list-style-type: none"> • TIME DELAY IN A MONOSTABLE • ADJUSTMENT OF OFFSET ERRORS IN PHOTOCELL CIRCUIT.
INSTRUMENTS	<ul style="list-style-type: none"> • CALIBRATION OF DIGITAL VOLT-METERS. • ADJUSTMENT OF TRIGGER, TIMING AND OTHER CIRCUITS IN GENERATORS AND OSCILLOSCOPE.

*YES, TRIMMERS CAN BE USED IN DIGITAL CIRCUITS!

90% OF ALL CIRCUITS USING TRIMMING POTENTIOMETERS BOIL DOWN TO ABOUT TWO DOZEN BASIC TYPES, SUCH AS:

- | | | | |
|---------------------|-----------------------------|----------------------|-----------------------|
| I. <u>AMPLIFIER</u> | II. <u>TIMER/OSCILLATOR</u> | III <u>REGULATOR</u> | IV. <u>CONVERSION</u> |
| A. AUDIO | A. ONE SHOT | A.VOLTAGE | D/A, A/D |
| B. RF | B. FREE RUNNING | B. CURRENT | V/F, F/V |
| C. OPERATIONAL | | | |

TYPICAL MULTI-TURN APPLICATIONS:
GAIN AND OFFSET ADJUSTMENT FOR AN OP AMP-

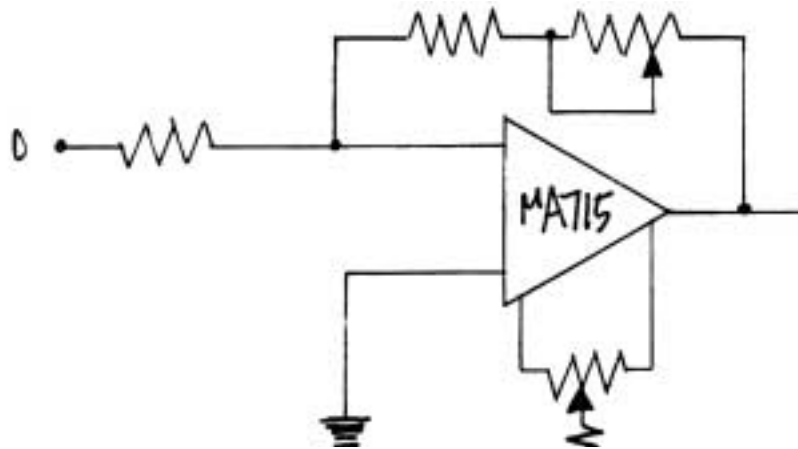

TIMING ADJUSTMENT OF MONOSTABLE

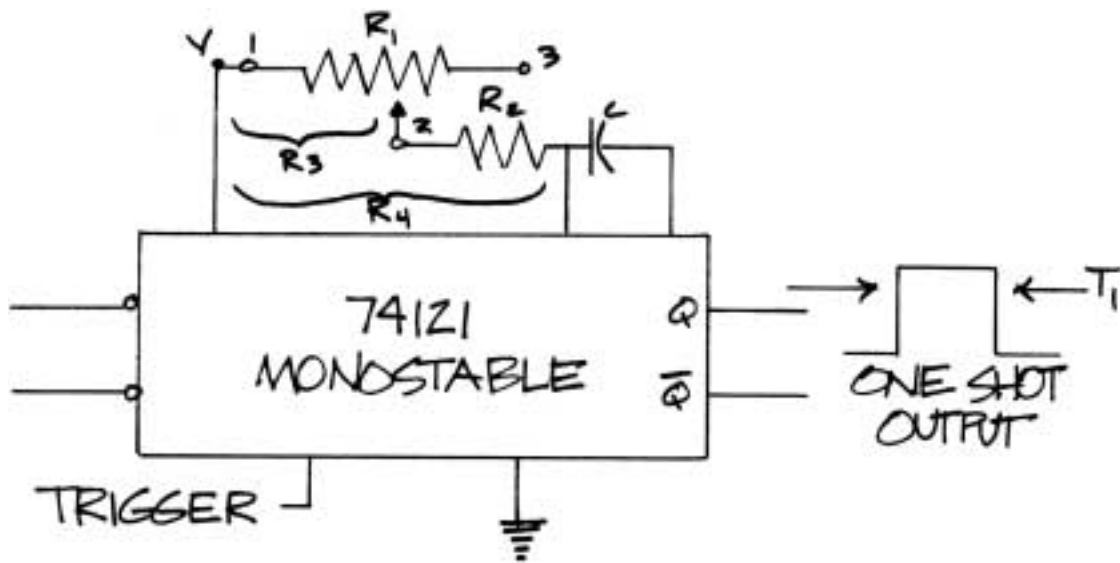

SHUNT REGULATOR

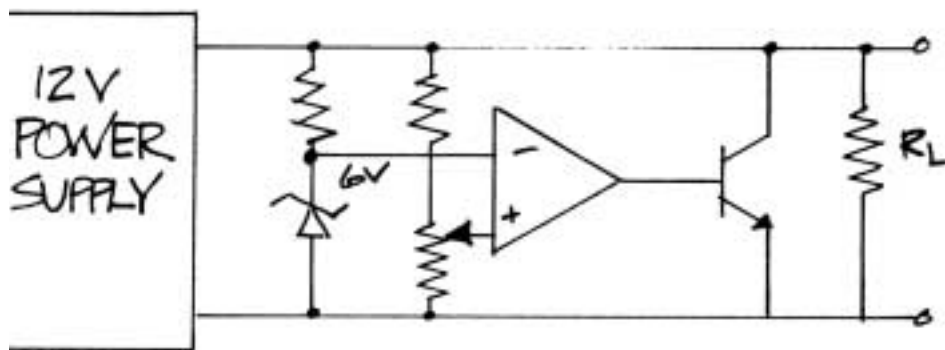

TYPES OF TRIMMERS

TRIMMERS CONSIST OF :

1. A RESISTIVE ELEMENT
2. TWO END TERMINALS
3. A MOVEABLE CONTACT (WIPER) AND CENTER TERMINAL
4. A CONTACT ACTUATOR (SHAFT, ADJUSTMENT SCREW OR ROTOR)

1. LEADSCREW ACTUATED

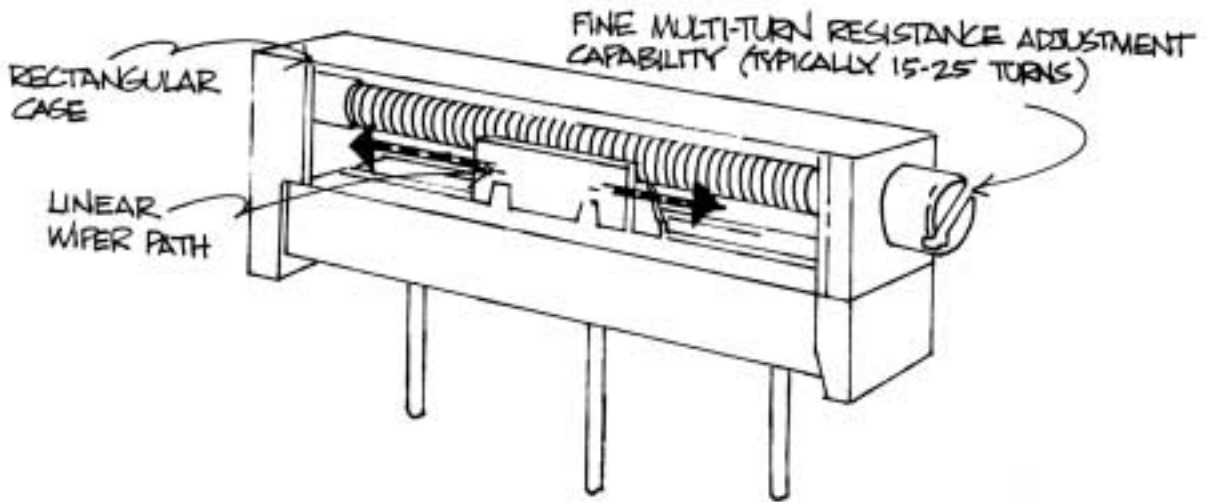

SIMILAR TO BOURNS® AND TRIMPOT® MODEL #'S WIREWOUND ELEMENTS: 3005, 3010, 3057 CERMET ELEMENTS: 20, 3006, 3009, 3012, 3059, 3082, 3099

2. WORM GEAR ACTUATED

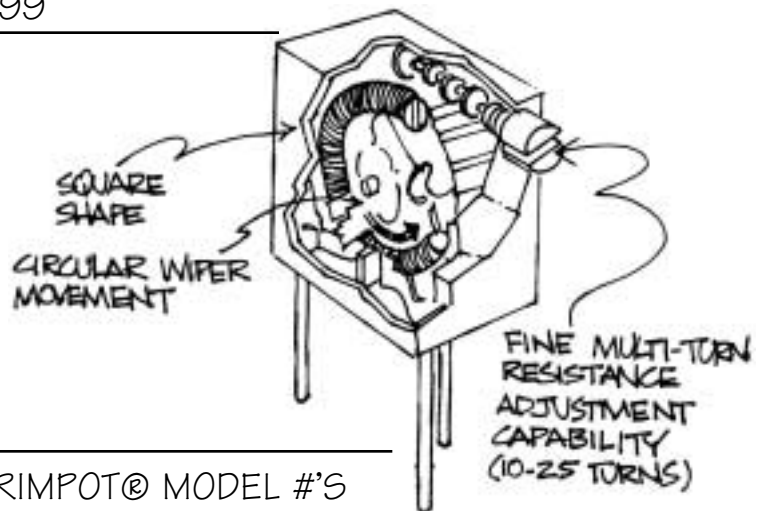

SIMILAR TO BOURNS® AND TRIMPOT® MODEL #'S WIREWOUND ELEMENTS: 3250, 3260, 3290 CERMET ELEMENTS: 3252, 3262, 3292, 3299

3. SINGLE-TURN

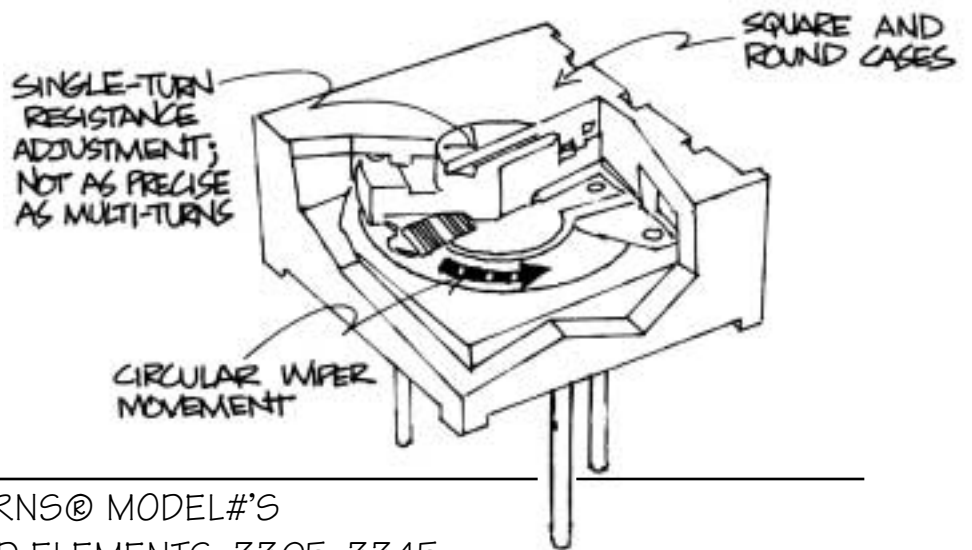

SIMILAR TO BOURNS® MODEL#’S

WIREWOUND ELEMENTS: 3305, 3345

CERMET ELEMENTS: 3329, 3339*, 3352, 3359, 3386

* A SPECIAL 4 TURN MODEL IN A SINGLE-TURN PACKAGE

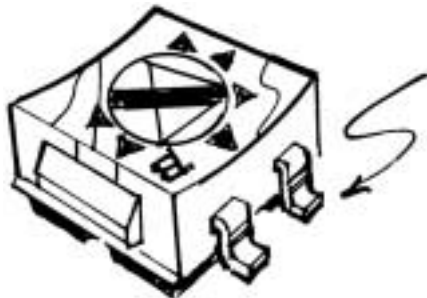

4. SURFACE MOUNT

TRIMMER LEADS SOLDER TO SURFACE OF BOARD TO SAVE SPACE AND IMPROVE PERFORMANCE. SEE LESSON 17 FOR DETAILS.

5. CENTER TAP

CENTER TAP DIVIDES THE POTENTIOMETER INTO 2 SEPARATE, INDEPENDENT UNITS. ESPECIALLY USEFUL IN OP-AMP APPLICATIONS, SEE LESSON 3 FOR MORE INFORMATION.

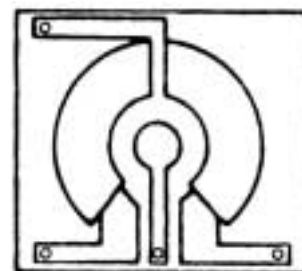

SINGLE TURN OR MULTI-TURN?

	SINGLE-TURN	MULTI-TURN
SETTING ACCURACY		✓
SPEED ADJUSTING TO ACCURATE SETTING TO APPROXIMATE SETTING	✓	✓

SETABILITY—SINGLE-TURN VS. MULTI-TURN—
 TECHNICIANS OR PRODUCTION WORKERS
 TYPICALLY ADJUST A MULTI-TURN TO A DESIRED SETTING
 FASTER THAN A SINGLE-TURN.

MULTI-TURN SETABILITY

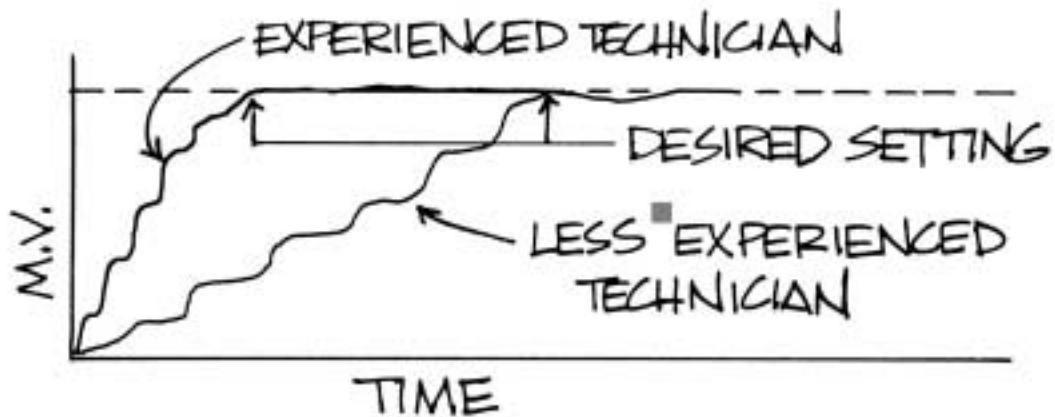

SINGLE-TURN SETABILITY

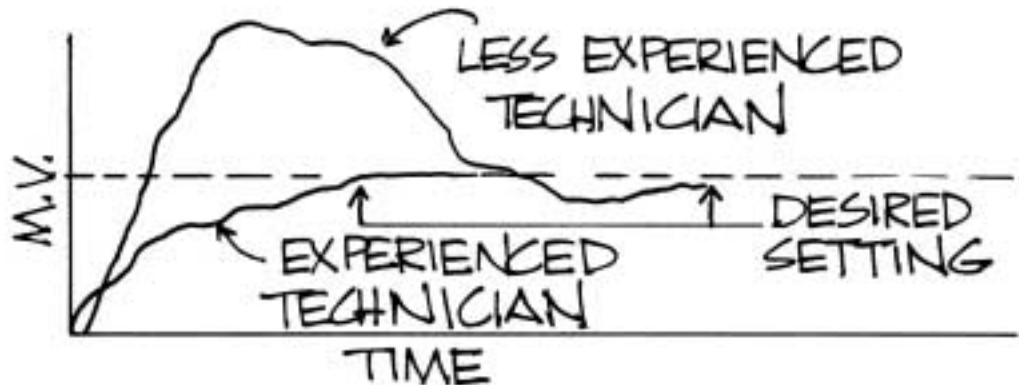

APPLICATIONS THAT USUALLY FAVOR THE COST-EFFECTIVE USE OF MULTI-TURN TRIMMERS:

1. OP AMP ZERO ADJUST- THE MULTI-TURN ADVANTAGE OVER SINGLE-TURNS IN THE APPLICATION IS A SHORTER ADJUSTMENT TIME TO AN ACCURATE SETTING.
2. VOLTAGE REGULATOR ADJUST SINGLE-TURN TRIMMERS USED IN THIS APPLICATION REQUIRE TWO FIXED RESISTORS. THE EXTENDED RANGE REACTOR OF A MULTI-TURN PROVIDES VOLTAGE DROPPING AND FINE ADJUST IN ONE UNIT.

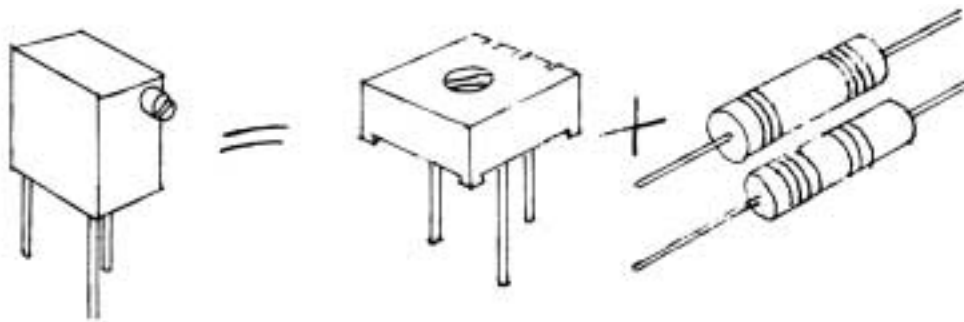

BOURNS MULTI-TURNS SAVE VALUABLE BOARD SPACE AND CUT COMPONENT INSTALLATION COSTS.

3. OSCILLATOR FREQUENCY ADJUSTMENT-MULTI-TURNS GIVE ACCURATE ADJUSTMENT, QUICKLY- EVEN WHEN DONE BY AN INEXPERIENCED OPERATOR.

NOTE: MULTI-TURNS AREN'T ALWAYS THE ANSWER. APPLICATIONS SUCH AS DATA-INPUT FOR DIGITAL EQUIPMENT, WHERE THE LEVEL OF ACCURACY IS NOT CRITICAL, ARE PERFECT FOR SINGLE-TURN TRIMMERS.

CERMET VS. WIREWOUND

THE RESISTIVE ELEMENT OF A TRIMMER MAY BE MADE OF A NUMBER OF MATERIALS. THE TWO MOST COMMON ARE A CONDUCTIVE GLASS/ METAL COMBINATION CALLED “CERMET”, AND WIREWOUND IN A COPPER MANDREL. (CARBON, ONCE WIDELY USED, IS NO LONGER COMMON FOR INDUSTRIAL APPLICATIONS.)

CERMET ELEMENTS (LINEAR WIPER PATH)

- ☑ HIGH RESOLUTION
SMALL INCREMENTAL
CHANGES IN OUTPUT
WITH WIPER TRAVEL)
- ☑ LOW TERMINATION
RESISTANCE

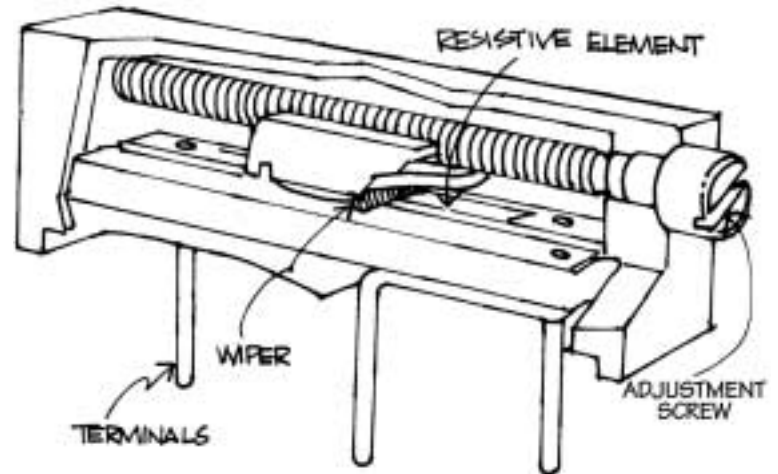

WIREWOUND ELEMENTS (CIRCULAR WIPER PATH)

- ☑ LONG CYCLING LIFE (WEAR)
- ☑ CONFORMITY OVER LIFE—
I.E: OUTPUT VS. WIPER POSITION
- ☑ LOW EQUIVALENT NOISE
RESISTANCE

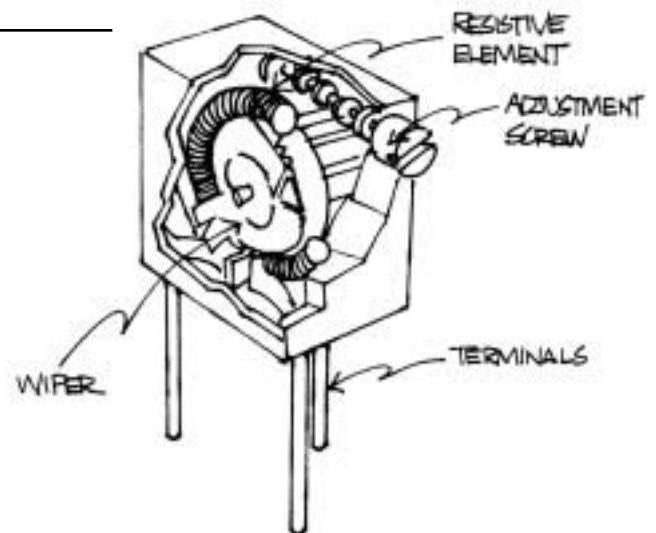

CERMET AND WIREWOUND ELEMENTS ARE PACKAGED IN RECTANGULAR, SQUARE AND ROUND CASES OR HOUSINGS.

WHICH ONE IS BETTER?

THE CHOICE BETWEEN CERMET AND WIREWOUND DEPENDS ON YOUR PARTICULAR REQUIREMENTS. THE CHECK MARK SHOWS WHICH ONE PERFORMS BETTER IN EACH CHARACTERISTIC.

	CERMET	WIREWOUND
RESISTANCE RANGE	10 -5M	10 -50K
LOW TEMP. COEFFICIENT		✓
HIGH POWER DISSIPATION		✓
TIGHT RESISTANCE TOLERANCE		✓
RESISTANCE STABILITY		✓
SETTING ACCURACY	✓	✓
LOW REACTANCE IN HIGH FREQUENCY CIRCUITS	✓	
LOWER COST	✓	
SMALLER SIZES	✓	
NOISE (DURING ADJUSTMENT)		✓

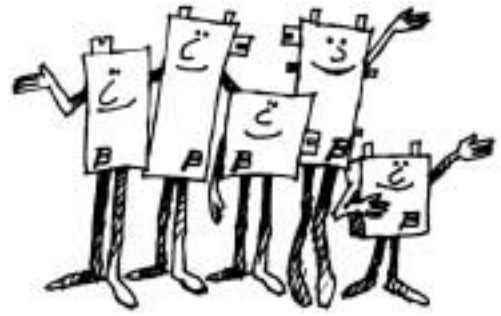

HOW TO SELECT THE RIGHT TRIMMER

CONSIDER THE FOLLOWING APPLICATION AND SELECTION FACTORS FOR THE BEST COST PERFORMANCE CIRCUIT DESIGN:

1. ELECTRICAL PARAMETERS—
 - A. CIRCUIT INTERFACE RESISTANCE VS. TRIMMER RESISTANCE.
 - B. CIRCUIT GAIN AND SENSITIVITY VS. TRIMMER RESOLUTION AND ADJUSTABILITY.
 - C. CIRCUIT VOLTAGE/CURRENT VS. TRIMMER POWER RATING.
 - D. NOISE TOLERANCE LIMIT VS. TRIMMER NOISE SPECIFICATION AND LOCATION IN CIRCUIT.

BOURNS DESIGNED THE MULTI-WIRE WIPER FOR LOW NOISE.

ELECTRICAL ABUSE AND MISUSE OF TRIMMERS ARE COMMON. CONTACTING A BOURNS ENGINEER AT THE START OF A CIRCUIT DESIGN CAN HELP REDUCE POTENTIAL PROBLEMS.



2. MECHANICAL REQUIREMENTS-ANSWER
THESE QUESTIONS:

- A. WHAT CASE STYLE AND PIN CONFIGURATIONS
ARE NEEDED?
- B. TOP OR SIDE ADJUSTMENT?
- C. IS A CUSTOM UNIT REQUIRED?

THE RIGHT SIZE, CASE AND PIN STYLE AND RESISTANCE VALUE IS
PROBABLY IN STOCK. CALLING BOURNS EARLY IN THE DESIGN
STAGES CAN SAVE COSTLY DELAYS.

3. THE ENVIRONMENT-



BE SURE THE TRIMMER'S TEMPERATURE COEFFICIENT
AND OPERATING TEMPERATURE MATCH THE ENVIRON-
MENT OF YOUR SYSTEM.

BOURNS THERMOPLASTIC HOUSING MEET OR EXCEED MIL-SPEC
ENVIRONMENTAL TEMPERATURE EXTREMES.

IF THE CIRCUIT BOARD WILL BE WASHED, CHECK OUT THE SEALING DESIGN AND INTEGRITY OF THE TRIMMER. PROPER TRIMMER SEALING IS A MUST IN A HUMID OR DIRTY OPERATING ENVIRONMENT.

MANY BOURNS UNITS INCORPORATE THE SELF-SEALING CHEVRON DESIGN TO HELP PROTECT AGAINST HUMIDITY AND BOARDWASHING.

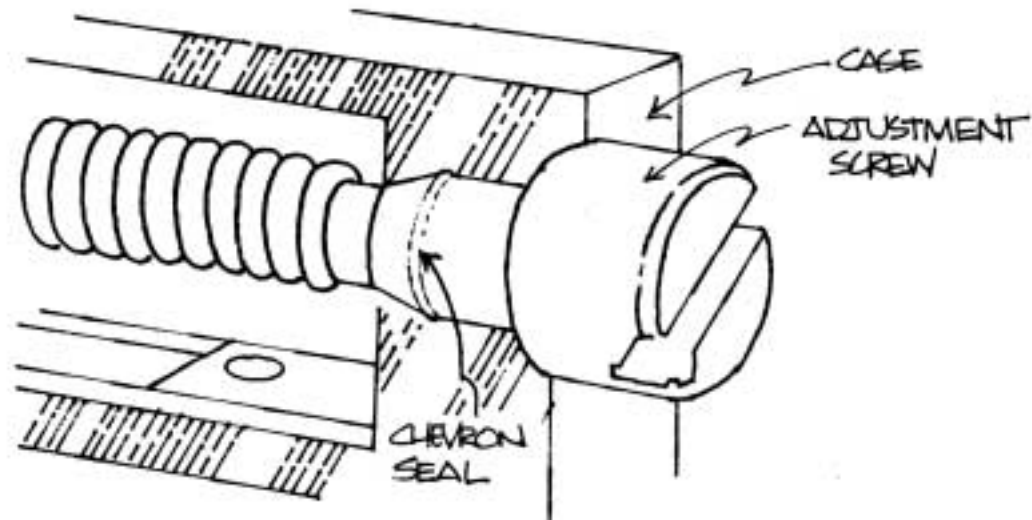

EXCESS VIBRATION AND SHOCK CAN DAMAGE A TRIMMER. SO MAKE SURE THE CONSTRUCTION CAN HANDLE ANY UNIQUE REQUIREMENTS.

4. DON'T FORGET HUMAN INTERFACE!

- A. THE ADJUSTMENT SCREW MUST BE IN AN ACCESSIBLE LOCATION ON THE CIRCUIT BOARD.
- B. SELECT THE TRIMMER BEST SUITED TO THE OPERATOR'S SKILL AND ADJUSTMENT TIME REQUIREMENTS. REMEMBER, NOT EVERYONE CAN MAKE FINE ADJUSTMENTS QUICKLY.

BOURNS MULTI-TURN TRIMMERS CAN GIVE A FASTER SETTING-TO-TIME-RATIO THAN SINGLE-TURNS.

5. RELIABILITY-

BE SURE TO SPEC TRIMMERS WITH SECURE RESISTIVE ELEMENT TERMINATIONS.

BOURNS SWAGE-BOND™ AND SILVERWELD® PIN ATTACHMENTS ARE DESIGNED FOR LONG TERM SECURITY AND RELIABILITY

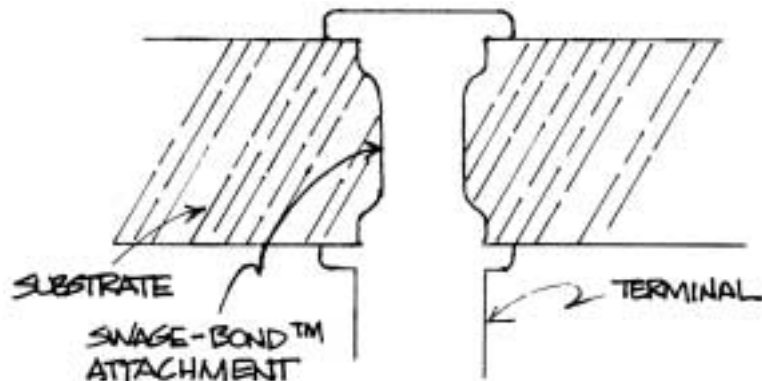

LESSON 2- TRIMMERS FOR SPECIAL REQUIREMENTS

HERE ARE A FEW HANDY TIPS ON SPECIAL APPLICATIONS.

☑ OP-AMP ADJUSTMENT-

A CENTER TAP TRIMMER SUCH AS BOURNS -0T1 ISOLATES BOTH OP-AMP POWER SUPPLIES TO REDUCE THE NEGATIVE EFFECT OF DRIFT. THIS RESULTS IN A 10X IMPROVEMENT IN VOLTAGE EFFECT ERROR CAUSED BY POWER SUPPLY DRIFT.

SCHEMATIC OF BOURNS
-0T1 CENTER TAP TRIMMING
POTENTIOMETER

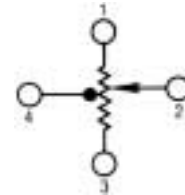

SUGGESTED OFFSET VOLTAGE ADJUSTMENTS
USING BOURNS -0T1

VOLTAGE FOLLOWER

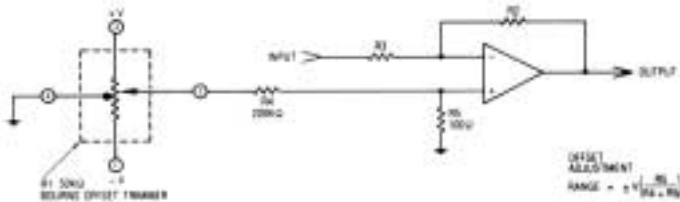
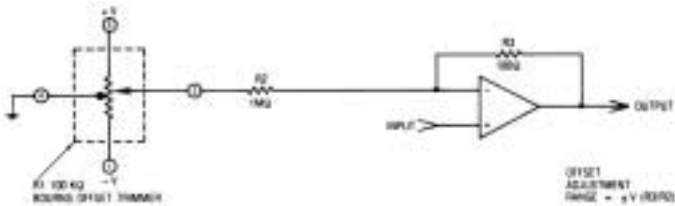

INVERTING AMPLIFIER

NON-INVERTING AMPLIFIER

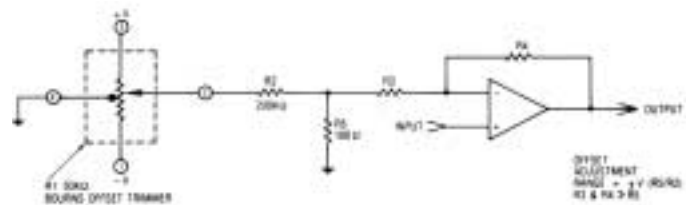

DIFFERENTIAL AMPLIFIER

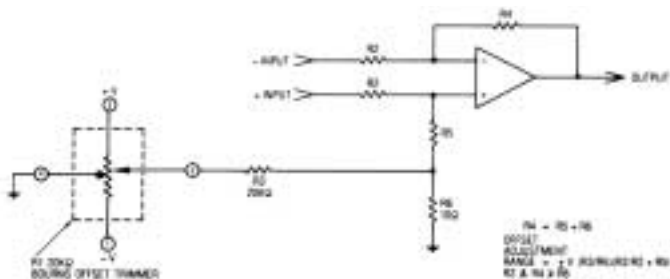

- ☑ COARSE/FINE ADJUSTMENT—
TWO TRIMMERS INSTEAD OF ONE CAN PROVIDE AN ADJUSTMENT THAT'S QUICK, EASY AND ACCURATE FOR THE USER.

TWO SINGLE-TURN TRIMMERS IN SERIES

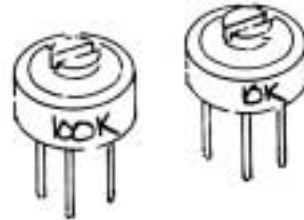

- ☑ NON-LINEAR—
THE CHANGE IN RESISTANCE FOR A GIVEN CHANGE IN WIPER POSITION IS TYPICALLY USED IN A LINEAR MODE. SPECIAL TRIMMERS CAN BE SUPPLIED THAT PROVIDE LOG ARITHMIC AND OTHER NON-COMPLEX TAPERS. CONSULT BOURNS FOR ASSISTANCE. OR ADD A FIXED RESISTOR BETWEEN THE CENTER TAP AND ONE END OF AN -OT1 TO MAKE YOUR OWN CUSTOM TAPER.

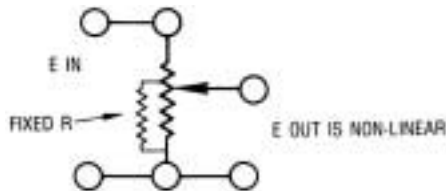

MAKING YOUR BOSS SMILE: SELECT A TRIMMER THAT SAVES MONEY.

OPEN FRAME-

YOU CAN SAVE MONEY BY BUYING AN OPEN-FRAME TRIMMER INSTEAD OF A SEALED ONE. BUT BEWARE- IF THE BOARD MUST BE WASHED, OPEN-FRAME UNITS MAY BECOME CONTAMINATED WITH RESIDUE, CREATING AN EXCESSIVE NUMBER OF BOARDS REJECTED AT FINAL INSPECTION OR WHILE IN USE BY YOUR CUSTOMER. A LOW-COST SEALED UNIT LIKE THE BOURNS 3386 MAY BE A LESS EXPENSIVE CHOICE IN THE LONG-RUN.

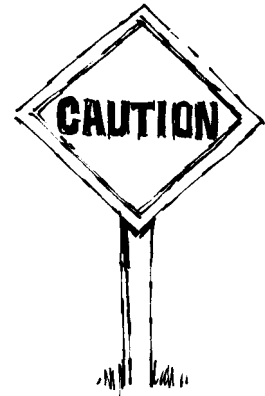

CONSERVING PC BOARD REAL ESTATE-
CONSIDER USING A TRIMMER THAT SITS ON EDGE INSTEAD OF FLAT ON THE BOARD.

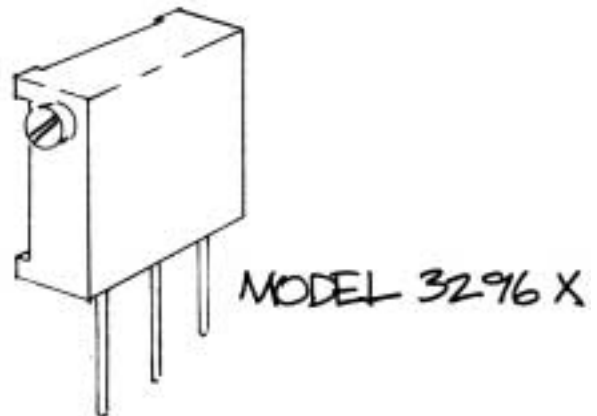

LESSON 3: THE ADVANCED COURSE

BEFORE WE BEGIN, LET'S LOOK AT THE BASIC OPERATING MODES OF A TRIMMER ONE MORE TIME.

1. THE VOLTAGE DIVIDER MODE, FROM WHICH THE DEVICE GOT ITS NAME.
2. THE RHEOSTAT MODE, WHERE THE UNIT IS USED AS A VARIABLE RESISTOR TO CONTROL THE FLOW OF CURRENT IN A CIRCUIT.

IN THE VOLTAGE DIVIDER MODE, THE POTENTIOMETER IS CONNECTED AS A THREE-TERMINAL DEVICE, SHOWN IN FIGURE 1. HERE THE POTENTIOMETER IS USED TO PROVIDE AN ADJUSTABLE OUTPUT VOLTAGE (E_o) THAT IS A FRACTIONAL VALUE OF SOME INPUT VOLTAGE (E_i).

VOLTAGE DIVIDER
MODE
FIGURE 1

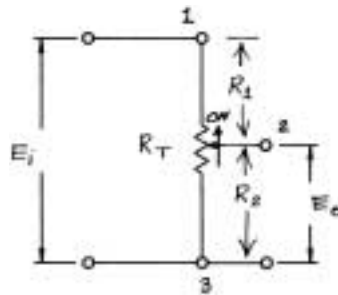

FOR THE CALCULATION EXAMPLE BELOW WE'LL CALL THE PORTION OF THE ELEMENT ABOVE THE WIPER CONTACT R_1 . THE PART BELOW THE WIPER CONTACT WE'LL CALL R_2 . THIS WAY WE CAN TREAT THE DEVICE AS A SIMPLE FIXED VOLTAGE DIVIDER.

USING OHM'S LAW, FOR ANY GIVEN WIPER SETTING WE CAN DETERMINE THAT THE OUTPUT VOLTAGE (E_o) IS RELATED TO THE INPUT VOLTAGE (E_i) BY THE RELATIONSHIP:

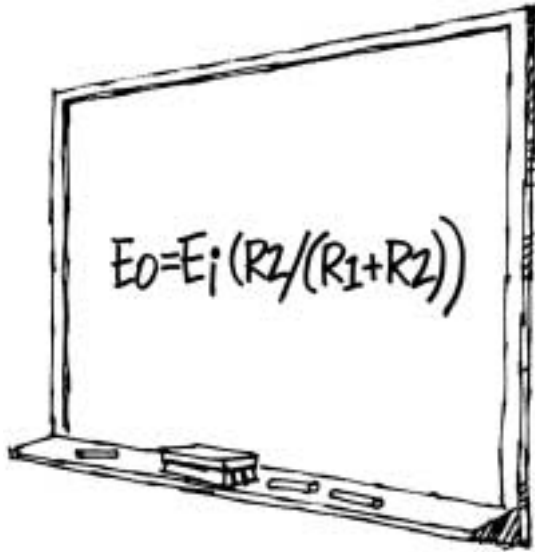

THE ABOVE RELATIONSHIP IS, OF COURSE, EXACT ONLY UNDER IDEAL CONDITIONS. FOR INSTANCE, IF WE ADD A LOAD RESISTANCE FROM THE WIPER TERMINAL TO GROUND, THE ABOVE EQUATION WOULD HAVE TO BE MODIFIED TO REFLECT THE CHANGE.

FOR PRACTICAL PURPOSES, HOWEVER, IF WE KEEP THE LOAD RESISTANCE FAIRLY HIGH (SAY AT LEAST TEN TIMES THE TOTAL POTENTIOMETER RESISTANCE) WE CAN IGNORE THE EFFECT OF THE LOAD RESISTANCE FOR MOST TRIMMER APPLICATIONS.

AS THE WIPER CONTACT IN FIGURE 1 IS MOVED, THE VALUES OF BOTH R_1 AND R_2 CHANGE, PRODUCING A CHANGE IN OUTPUT VOLTAGE (E_o) THAT IS DIRECTLY PROPORTIONAL TO THE WIPER POSITION (FIGURE 2)

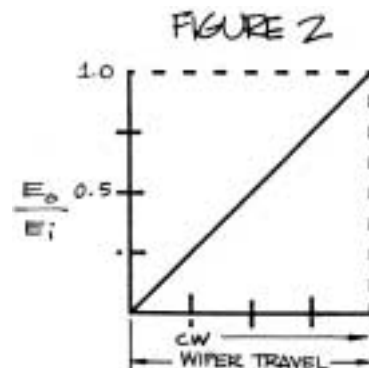

FOR SPECIAL APPLICATIONS, SOME POTENTIOMETERS ARE DESIGNED TO PRODUCE AN OUTPUT THAT IS NOT LINEAR, AS IN AUDIO VOLUME CONTROLS. TRIMMERS, ON THE OTHER HAND, ARE SELDOM USED IN THIS TYPE OF APPLICATION. THEY ARE USUALLY DESIGNED TO PRODUCE THE NOMINALLY LINEAR OUTPUT SHOWN IN FIGURE 2.

IN THE RHEOSTAT MODE, THE TRIMMER IS CONNECTED AS A TWO-TERMINAL DEVICE, SHOWN IN FIGURES 3A AND 3B. IN THIS MODE OF OPERATION, WHICH ACCOUNTS FOR OVER HALF OF ALL TRIMMER APPLICATIONS, THE POTENTIOMETER IS USED SIMPLY AS A VARIABLE RESISTOR TO CONTROL THE FLOW OF CURRENT IN A SERIES CIRCUIT.

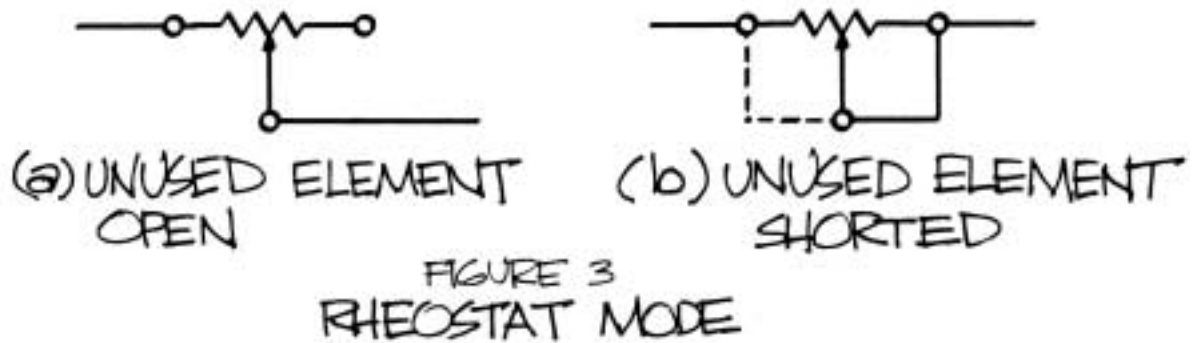

FIGURE 3
RHEOSTAT MODE

IN THE RHEOSTAT MODE THERE IS NO BASIC INPUT-OUTPUT RELATIONSHIP, EXCEPT AS DEFINED BY ASSOCIATED CIRCUITRY IN WHICH THE TRIMMER IS BEING USED.

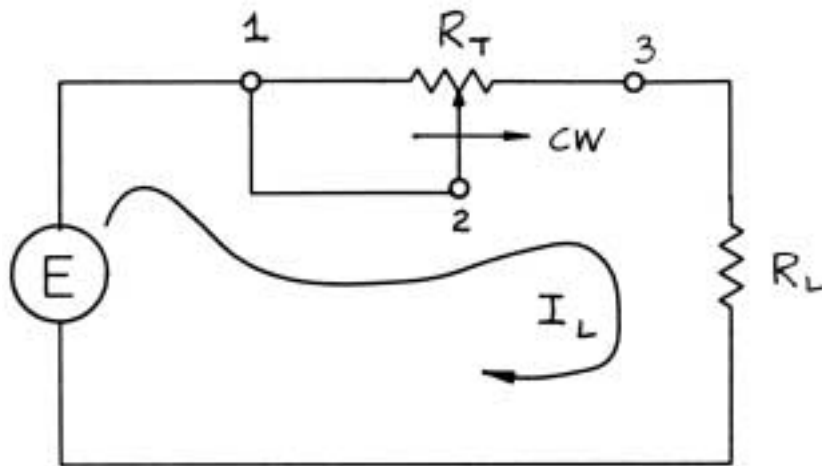

FIGURE 4

FOR EXAMPLE, IN FIGURE 4 WE CAN SEE THAT AS THE WIPER CONTACT IS MOVED IN THE CW DIRECTION, AN INCREASING PORTION OF THE RESISTANCE ELEMENT IS SHORTED OUT BY THE JUMPER CONNECTION BETWEEN TERMINALS 1 AND 2. THIS REDUCES THE TOTAL RESISTANCE OF THE TRIMMER AND ALLOWS AN INCREASE IN THE FLOW OF CURRENT (I_L) TO THE LOAD (R_L).

PAY CLOSE ATTENTION NOW. YOU MIGHT EVEN WANT TO DIG OUT YOUR YELLOW MARKER.

THIS MEANS THAT VIRTUALLY ALL OF THE LOAD CURRENT PASSES THROUGH THE WIPER CONTACT. AND YOU MUST REMEMBER THAT IN THE RHEOSTAT MODE OF OPERATION, THE MAXIMUM CURRENT IN THE CIRCUIT IS LIMITED ONLY BY THE SOURCE VOLTAGE AND LOAD RESISTANCE AS THE WIPER IS ADJUSTED TO THE POSITION OF MINIMUM RESISTANCE, THERE'LL BE MORE ON THIS LATER.

LINEARITY, ADJUSTABILITY AND RESOLUTION

AS WE MENTIONED EARLIER, TRIMMERS ARE NORMALLY DESIGNED TO PRODUCE A LINEAR OUTPUT. HOWEVER AS YOU MAY HAVE ALREADY SURMISED FROM WORKING WITH OTHER ELECTRICAL COMPONENTS, THEY'RE NOT EXACTLY PERFECT.

THE CHANGE IN OUTPUT AS A FUNCTION OF WIPER TRAVEL CAN DEVIATE FROM THE OPTIMUM AS ILLUSTRATED IN FIGURE 5A. HOWEVER, OVERALL LINEARITY IS USUALLY NO PROBLEM IN MOST TRIMMER APPLICATIONS, AND IS NEVER SPECIFIED.

ON THE OTHER HAND, IF WE MAGNIFY THE OUTPUT CURVE, FIGURE 5B, YOU CAN SEE THAT WHAT APPEARED TO BE A SMOOTH STRAIGHT LINE IS REALLY A SERIES OF VERY SMALL IRREGULARITIES. SOMETIMES WE CALL THEM LOFTY NAMES LIKE "MICRO-NON-LINEARITIES." MOST DESIGNERS USUALLY JUST CALL THEM "NOISE" (OR EVEN LESS COMPLIMENTARY NAMES).



MORE OFTEN THAN NOT, THIS NOISE IS CAUSED BY SMALL IMPERFECTIONS IN THE COMPOSITION OF THE RESISTANCE ELEMENT AND CHANGES IN THE ELECTRICAL CURRENT PATH AS THE WIPER TRAVELS OVER THE ELEMENT. AS SMALL AS THEY ARE, THEY'RE IMPORTANT IN TRIMMER APPLICATIONS BECAUSE THEY EFFECTIVELY LIMIT THE ADJUSTABILITY (RESOLUTION) AND STABILITY OF THE UNIT.

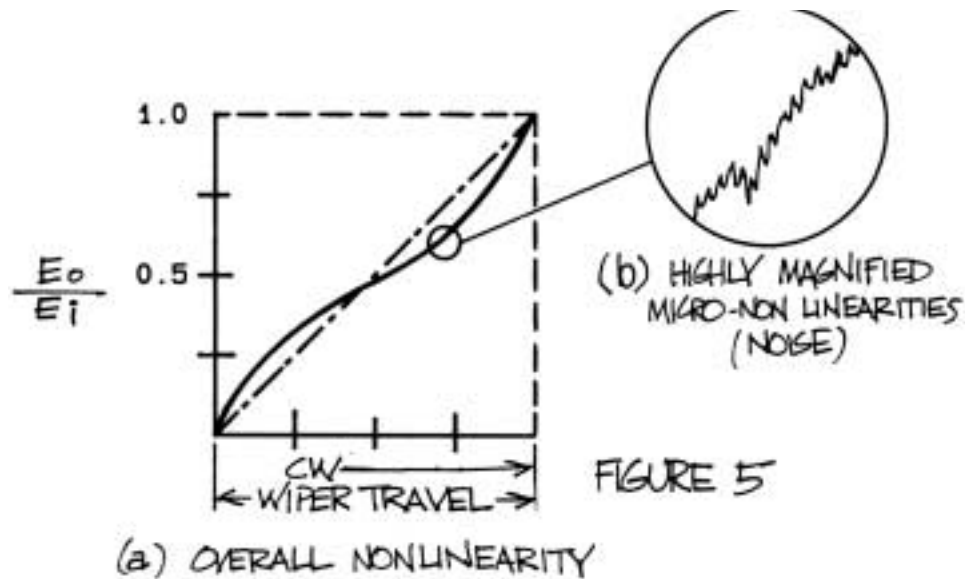

MOST SINGLE-TURN TRIMMERS CAN BE SET TO WITHIN 0.05% OF THE TOTAL APPLIED VOLTAGE (VOLTAGE DIVIDER MODE) OR 0.15% OF TOTAL RESISTANCE (RHEOSTAT MODE). HOWEVER, FOR SOME APPLICATIONS THAT'S NOT GOOD ENOUGH. SO THERE ARE TWO WAYS YOU CAN GET AROUND IT .

1. USE A MULTI-TURN UNIT TO GIVE BETTER ADJUSTABILITY.

2. USE ADDITIONAL FIXED RESISTORS AS PART OF THE ADJUSTMENT NETWORK TO YIELD THE DESIRED FINE ADJUSTMENT CHARACTERISTICS.

ADDING RESISTANCE IN SERIES WITH THE TRIMMER WILL REDUCE THE OVERALL ADJUSTMENT RANGE OF THE CIRCUIT BUT ALLOW FINER TUNING.

END ZONE CHARACTERISTICS

POTENTIOMETERS NORMALLY HAVE A SMALL REGION AT THE EXTREME ENDS OF THE ADJUSTMENT RANGE WHERE THE OUTPUT IS IRREGULAR. THIS CAN BE SEEN WHEN THERE'S A SUDDEN DROP TO ESSENTIALLY ZERO RESISTANCE. OR THE CHANGE IN OUTPUT WILL STOP AT SOME SMALL RESIDUAL VALUE OF RESISTANCE, DEPENDING ON THE DESIGN OF THE TRIMMER.

ALTHOUGH THIS UNSTABLE REGION IS USUALLY LESS THAN 1 OR 2% OF THE TOTAL RANGE OF ADJUSTMENT, IT'S IMPORTANT THAT YOU REMEMBER TO MAKE ALLOWANCES FOR AVOIDING IT IN YOUR CIRCUIT APPLICATIONS.



POWER AND CURRENT RATINGS

THE POWER RATINGS OF TRIMMING POTENTIOMETERS ARE USUALLY MORE THAN ADEQUATE FOR MOST VOLTAGE DIVIDER APPLICATIONS WHERE THE POWER IS DISSIPATED EVENLY OVER THE ENTIRE LENGTH OF THE ELEMENT UNDER ALL CIRCUMSTANCES.

KEEP IN MIND, HOWEVER, THAT THE STATED POWER RATING IS FOR THE ENTIRE RESISTANCE ELEMENT. UNUSUALLY LOW VALUES OF LOAD RESISTANCE CAN CAUSE UNEXPECTED HIGH LEVELS OF POWER DISSIPATION IN THE UNLOADED PORTION OF THE ELEMENT WHEN THE WIPER IS SET AT HIGH VALUES OF VOLTAGE RATIO.

FORTUNATELY, POWER DISSIPATION AND WIPER CURRENT USUALLY ONLY BECOME PROBLEMS WHEN TRIMMERS ARE USED IN THE RHEOSTAT MODE. LIKE WE SAID EARLIER, IN THIS MODE THE CURRENT THROUGH THE TRIMMER ELEMENT AND THE WIPER CONTACT IS LIMITED ONLY BY EXTERNAL CIRCUIT CONDITIONS.

THIS IS WHERE YOU AS A DESIGNER, MUST MAKE SURE YOU LIMIT THE WIPER CURRENT TO THE MAXIMUM VALUE STATED IN THE TRIMMER SPECS. IF YOU DON'T-ZAP!! EXCEEDING THE MAXIMUM WIPER CURRENT HAS CAUSED MORE TRIMMER PROBLEMS THAN ANY OTHER DESIGN ERROR.

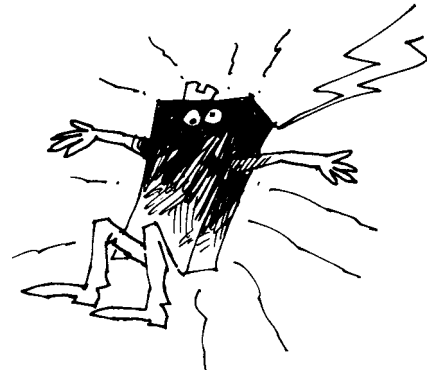

IF THE MAXIMUM WIPER CURRENT SPEC. ISN'T AVAILABLE, YOU CAN SAFELY ASSUME THAT IT IS THE CURRENT THAT WOULD PRODUCE MAXIMUM POWER DISSIPATION IN THE TRIMMER, IF APPLIED THROUGH THE ELEMENT ONLY, PROVIDED IT DOESN'T EXCEED 100 MILLIAMPS.

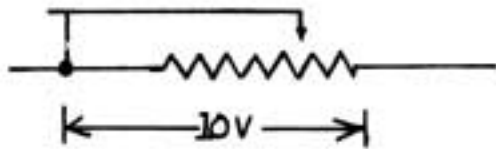

CAUTION! THIS CAN BECOME A DIRECT SHORT - AND THEN----

ZAP!

(SEE CURRENT LIMITS IN TABLE 1)

THE TABLE BELOW SHOWS THE MAXIMUM WIPER CURRENT FOR DECADE RESISTANCE VALUES FOR SEVERAL TRIMMER POWER RATINGS. THE 100 MILLIAMP MAXIMUM WIPER CURRENT RATING (#) IS APPLICABLE ONLY ON TRIMMER VALUES OF LESS THAN 100 OHMS.

TABLE 1- MAXIMUM WIPER CURRENT VERSUS POWER RATINGS.

TRIMMER RESISTANCE	TRIMMER POWER RATING		
	0.25 WATT	0.5 WATT	1.0 WATT
10 OHMS	100 MA #	100 MA #	100 MA #
100 OHMS	50 MA	71 MA	100 MA
1 K OHMS	16 MA	22 MA	32 MA
10K OHMS	5.0 MA	7.1 MA	10 MA
100K OHMS	1.5 MA	2.2 MA	3.2 MA
1 M OHMS	0.5 MA	0.7 MA	1.0 MA

RESISTANCE VALUES AND TOLERANCES

WHILE IT'S ALWAYS EASIER TO WORK WITH STANDARD PARTS INVENTORIES, YOU STILL HAVE TO KEEP IN MIND THAT TO REACH OPTIMUM STABILITY AND ADJUSTABILITY, YOU NEED TO USE THE SMALLEST VALUE OF TRIMMER RESISTANCE YOUR APPLICATION ALLOWS.

HERE'S ANOTHER TIDBIT. WHEN YOU'RE WORKING IN CRITICAL APPLICATIONS, TRY TO AVOID THE EXTREMES OF RESISTANCE RANGE WHEN YOU'RE SELECTING A TRIMMER. ALTHOUGH THE ENTIRE RANGE WILL MEET THE STATED SPECIFICATIONS, MID-RANGE VALUES TEND TO PERFORM BETTER THAN LOW AND HIGH VALUES.

DRY CIRCUIT CONDITIONS

AS FAR AS POTENTIOMETERS GO, DRY CIRCUIT CONDITIONS RESULT FROM EXTREMELY LOW VALUES OF WIPER CURRENT. PAST STUDIES SHOW THAT UNDER EXTENDED TIME AND TEMPERATURE CONDITIONS, OXIDE FILMS CAN FORM AT THE JUNCTION OF METALLIC ELECTRICAL CONTACTS, SUCH AS THE POINT OF CONTACT BETWEEN MECHANICAL SWITCHING ELEMENTS. USUALLY THIS DOESN'T CAUSE A PROBLEM IN TRIMMER APPLICATIONS, SINCE NORMAL OPERATING CURRENT LEVELS PRODUCE ENOUGH "PUNCH THROUGH" VOLTAGE AT THE WIPER JUNCTION TO BREAK DOWN OXIDE OR CONTAMINANT FILMS.



BUT WITH THE TREND TOWARD LOWER LEVELS OF CURRENT OPERATION, DRY CIRCUIT CONDITIONS CAN LEAD TO SOME DEGRADATION IN PERFORMANCE- ESPECIALLY IN THE AREA OF LONG-TERM STABILITY.

HERE AT BOURNS TRIMPOT WE'VE CONDUCTED EXTENSIVE WORK TO BETTER DEFINE DRY CIRCUIT CONDITIONS FOR NON-METALLIC JUNCTIONS IN COMPOSITION POTENTIOMETERS. WE'VE DEVELOPED OUR OWN PROPRIETARY CERMET MATERIALS TO IMPROVE PERFORMANCE UNDER THESE CONDITIONS.

HOWEVER, WE STILL RECOMMEND THAT YOU PROVIDE A LOW ENOUGH LOAD RESISTANCE ACROSS THE WIPER OF THE POTENTIOMETER TO INSURE AN ABSOLUTE MINIMUM WIPER CURRENT OF 25 MICROAMPS AND PREFERABLY OVER 100 MICROAMPS. THIS SHOULD GIVE YOU ENOUGH CURRENT THROUGH THE WIPER TO HELP YOU AVOID DRY CIRCUIT PROBLEMS OVER EXTENDED PERIODS OF TIME AND TEMPERATURE.

MORE CIRCUIT APPLICATIONS

LET'S TAKE A LOOK AT A FEW OF THE MORE POPULAR ACTUAL CIRCUIT APPLICATIONS THAT USE TRIMMERS. WE'LL SHOW YOU HOW TO IMPROVE CIRCUIT PERFORMANCE WITH PROPER SELECTION AND USE OF THE TRIMMERS.

ONE OF THE MOST COMMON TRIMMER POTENTIOMETER APPLICATIONS TODAY IS THE ADJUSTMENT OF OFFSET VOLTAGE IN OPERATIONAL AMPLIFIERS, FIGURE 6

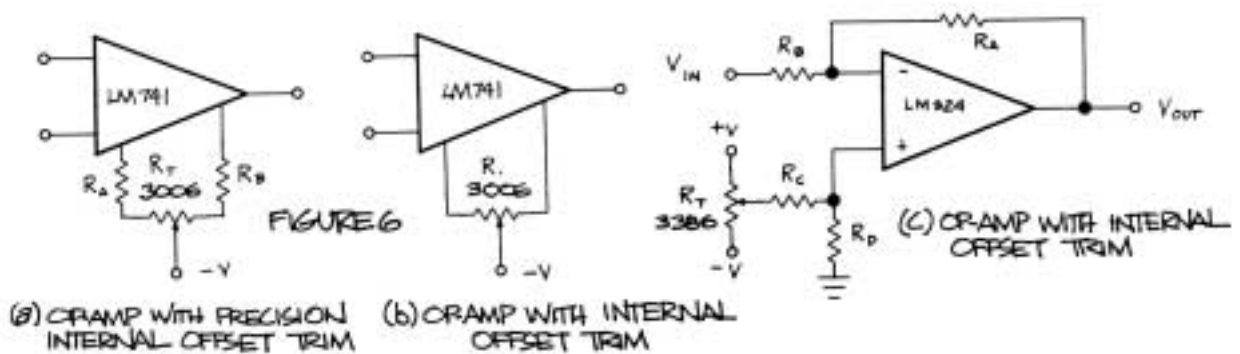

IN SOME CASES IT IS IMPOSSIBLE OR UNDESIRABLE TO TRIM INPUT OFFSET VOLTAGE USING MANUFACTURER PROVIDED TERMINALS AS SHOWN ABOVE. OTHER EXTERNAL CIRCUITS HAVE BEEN DEVELOPED TO COMPENSATE FOR THE INPUT OFFSET VOLTAGE WITHOUT USE OF OP-AMP OFFSET ADJUST TERMINALS. THE MORE COMMON CIRCUITS USED FOR THIS PURPOSE, SHOWN IN LESSON 2 DEMONSTRATE THE USE OF OUR -OT1 DEVICES.

THE OFFSET VOLTAGE MAY EITHER BE POSITIVE OR NEGATIVE WITH RESPECT TO THE GROUND, SO THE COMPENSATING VOLTAGE PROVIDED BY THE TRIMMING NETWORK MUST ALSO BE ADJUSTABLE OVER A POSITIVE TO NEGATIVE RANGE THAT IS GREAT ENOUGH TO INCLUDE THE HIGHEST AND LOWEST OFFSET VOLTAGE THAT MAY BE ENCOUNTERED. THE SPECIAL CENTER TAPPED ELEMENT OF THE -OT1 REDUCES POWER SUPPLY SENSITIVITY BY ISOLATING THE SUPPLIES, MINIMIZING THE EFFECTS OF SUPPLY DRIFT ON THE OFFSET ADJUSTMENT VOLTAGE.

SINCE YOU MAY ALSO REDUCE THE NUMBER OF COMPONENTS IN THE NETWORK BY EMPLOYING THE -OT1, YOU WILL ALSO SEE IMPROVEMENTS IN THE THERMAL STABILITY OF THE OFFSET VOLTAGE PERFORMANCE OF YOUR SYSTEM.

MOST OF THE PROBLEMS YOU HAVE IN THIS APPLICATION ARE USUALLY DUE TO THERMOELECTRIC EFFECTS. SMALL VOLTAGES ARE GENERATED AT THE ELEMENT TERMINATION POINTS AND AT THE TRIMMER-TO-CIRCUIT-BOARD INTERFACE. THIS IS DUE TO THE DIS-SIMILAR METALS USED IN THE MANUFACTURING PROCESS.

IF THE TRIMMER IS AT THE SAME TEMPERATURE THESE VOLTAGES WILL BALANCE OUT AND HAVE NO NET EFFECT ON CIRCUIT OPERATION. HOWEVER, IF THERE'S A THERMAL GRADIENT ACROSS THE TERMINALS OF THE TRIMMER ENOUGH DIFFERENTIAL VOLTAGE MAY BE GENERATED TO DISTURB THE BALANCE OF YOUR CIRCUIT. THE EMF GENERATED WILL DEPEND ON THE MAGNITUDE OF THE TEMPERATURE GRADIENT AND THE MATERIALS USED IN THE TRIMMER AND CIRCUIT BOARD. UNDER EXTREME CONDITIONS, THE THERMAL EMF CAN BE AS HIGH AS 100 MICROVOLTS.

YOU CAN'T ELIMINATE THE THERMAL EMF PROBLEM ENTIRELY. BUT YOU CAN MINIMIZE IT. TRY TO KEEP THE OP AMP AND THE TRIMMER OUT OF ENVIRONMENTS THAT HAVE HIGH THERMAL GRADIENTS. AVOID PLACING THE TRIMMER NEAR HOT COMPONENTS.



DRY CIRCUIT CONDITIONS CAN ALSO BE A PROBLEM IN THIS APPLICATION, PARTICULARLY WHEN THE TRIMMER IS USED FOR INTERNAL OFFSET TRIM AS SHOWN IN FIGURES 6(A) AND 6(B). ALWAYS SELECT THE LOWEST VALUE OF TRIM NETWORK RESISTANCE COMPATIBLE WITH THE OP AMP MANUFACTURER'S RECOMMENDATIONS, REMEMBERING THAT GOING TOO LOW WILL GOBBLE UP THE OP AMP'S OFFSET THERMAL DRIFT CHARACTERISTICS.

IN EXTERNAL OFFSET TRIM CIRCUITS AS SHOWN IN FIGURE 6(C), TRY TO KEEP R_T , R_C , AND R_D AS LOW AS YOU REASONABLY CAN, AGAIN TO MINIMIZE DRY CIRCUIT PROBLEMS.

LIKE WE SAID EARLIER, OVER HALF OF ALL TRIMMER APPLICATIONS ARE IN THE RHEOSTAT MODE— TWO EXAMPLES ARE THE VOLTAGE REGULATOR CIRCUIT IN FIGURE 7 AND THE OP AMP CIRCUITS IN FIGURE 8.

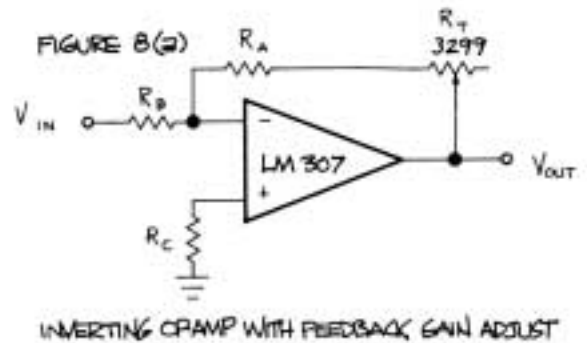
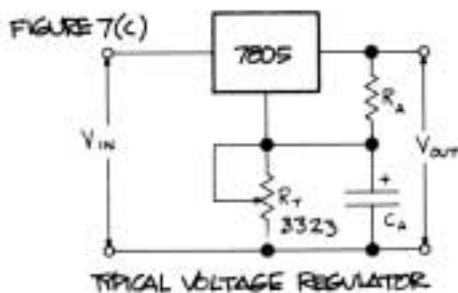
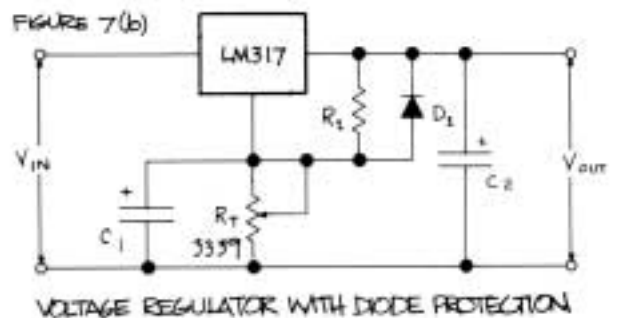
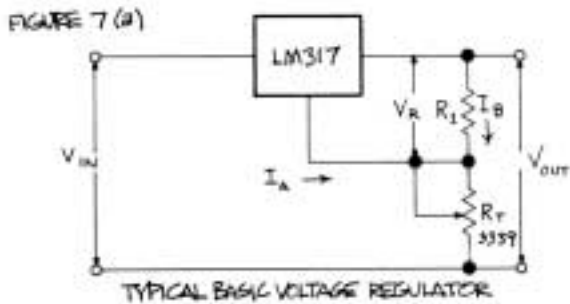

OUR STUDY SHOWED US THAT IN ABOUT HALF THE RHEOSTAT APPLICATIONS, DESIGNERS USE THIS CONFIGURATION BY MAKING CONNECTIONS TO ONE END OF THE RESISTANCE ELEMENT AND THE WIPER, LEAVING THE OTHER ELEMENT TERMINAL OPEN AS SHOWN IN FIGURE 8A.

WHAT'S WRONG WITH THIS? WELL A COUPLE OF THINGS. TAKE A LOOK AT FIGURE 8B.

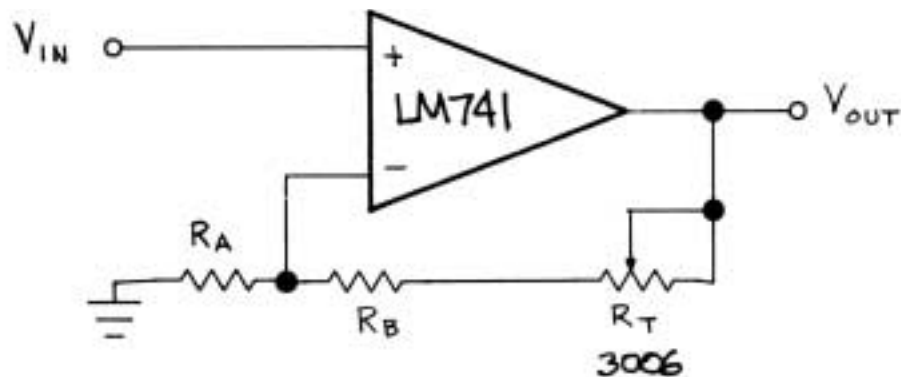

NON-INVERTING OP-AMP WITH FEEDBACK GAIN ADJUST
FIGURE 8(B)

FIRST, NOTICE THAT THE UNUSED PORTION OF THE ELEMENT IS NOW IN PARALLEL WITH THE VARIABLE WIPER CONTACT RESISTANCE. THAT MEANS YOU COULD PICK UP SOME IMPROVEMENT IN CRV (CONTACT RESISTANCE VARIATION) DURING ADJUSTMENT AND SETTING STABILITY DURING STATIC OPERATION.

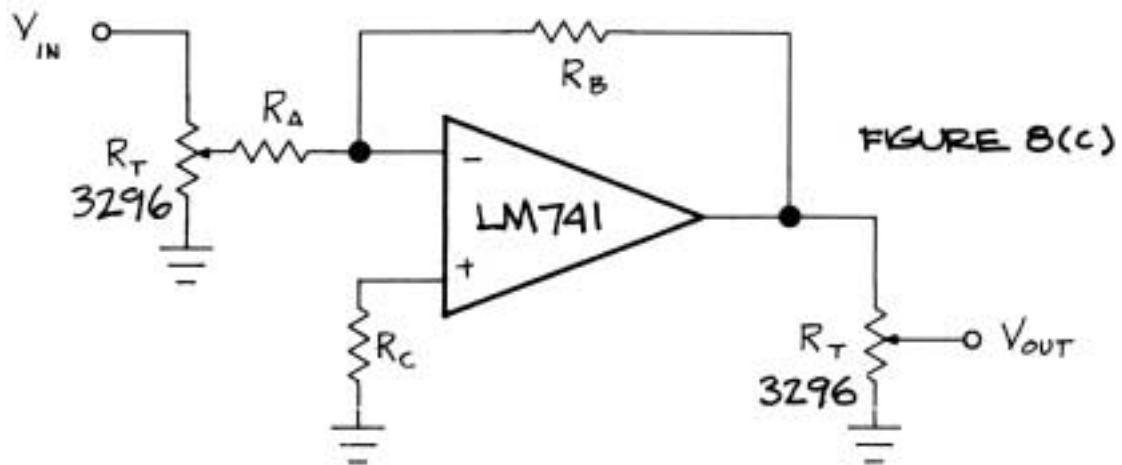

OP-AMP INPUT OR OUTPUT GAIN ADJUSTMENT

SECOND, KEEP IN MIND THAT THE OPEN WIPER CONDITION IS THE MODE WHERE MOST TRIMMERS MEET THEIR DOWNFALL. IF THIS HAPPENS, THE OUTPUT IN BOTH EXAMPLES WOULD BE FORCED TO THE EXTREME LIMITS PERMITTED BY THE SUPPLY VOLTAGES, AND THAT COULD DAMAGE OTHER COMPONENTS IN THE SYSTEM.

IF THE UNUSED PORTION OF THE TRIMMER ELEMENT IS TIED TO THE WIPER, THE OUTPUT OF BOTH CIRCUITS CAN ONLY SHIFT BY THE AMOUNT PERMITTED BY THE TOTAL TRIMMER RESISTANCE AND WHAT DOES THAT GET YOU? IMPROVED RELIABILITY IN BOTH CASES.

TAKE OUR ADVICE: TIE UP YOUR LOOSE ENDS ON RHEOSTATS.



AND REMEMBER, ALWAYS USE THE SMALLEST VALUE OF TRIMMER RESISTANCE THAT WILL GIVE THE RANGE OF ADJUSTMENT NEEDED BY YOUR APPLICATION.

THERE SEEMS TO BE A TENDENCY FOR DESIGNERS TO USE THE TRIMMER TO SATISFY THE TOTAL RESISTANCE REQUIRED BY THAT LEG OF A SERIES NETWORK. YOU CAN SEE THAT IN FIGURES 9A AND 9D, WHERE IT'S ASSUMED THAT ONLY A SMALL ADJUSTMENT OF FREQUENCY IS NEEDED. BUT A LARGER VALUE OF TRIMMER RESISTANCE IS USED TO AVOID AN ADDITIONAL FIXED RESISTANCE TO SET THE CENTER FREQUENCY. THAT'S A COMMON MISUSE OF THE TRIMMER.

TYPICAL OSCILLATOR CIRCUIT
FIGURE 9(a)

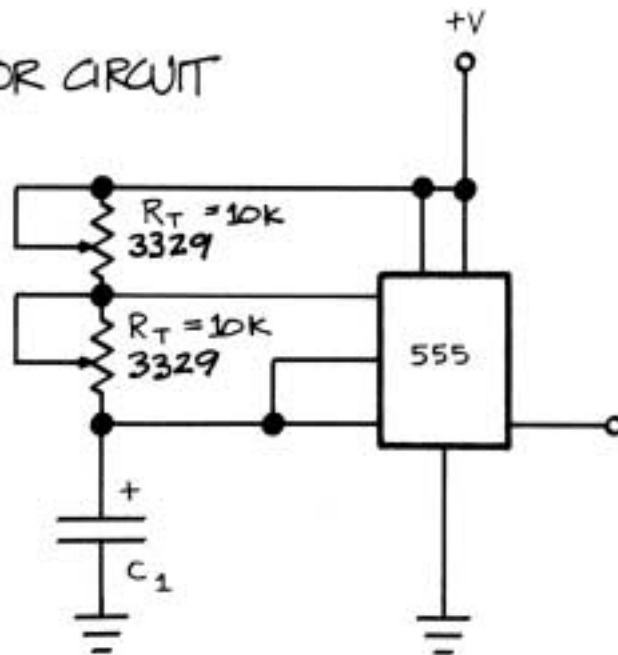

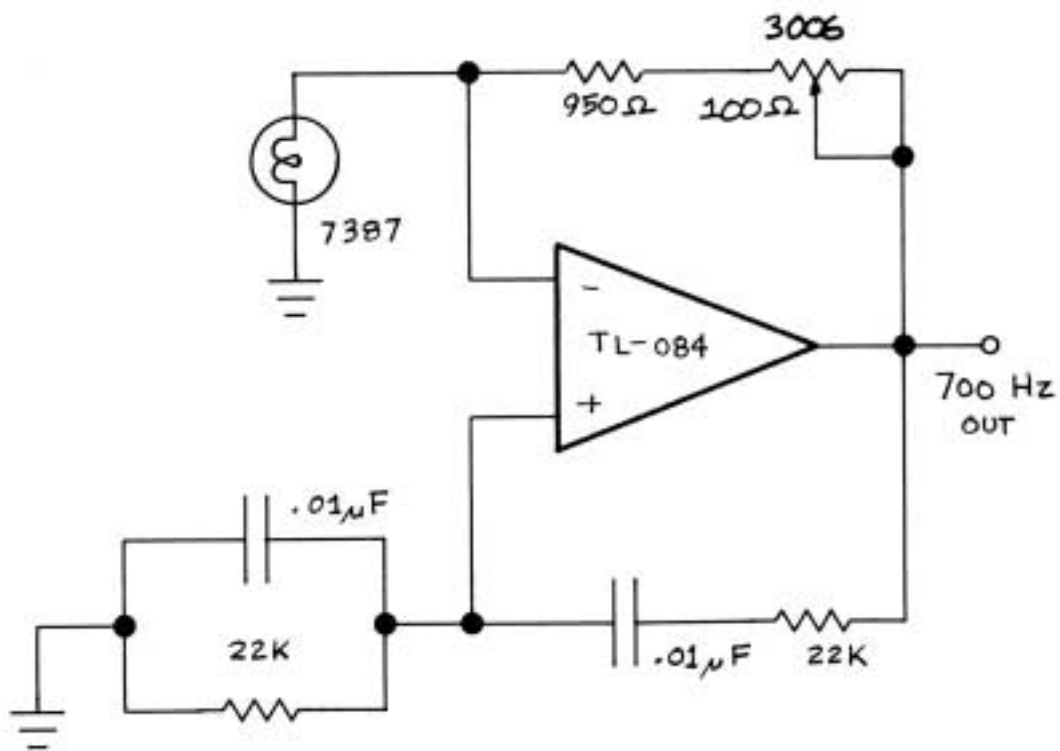
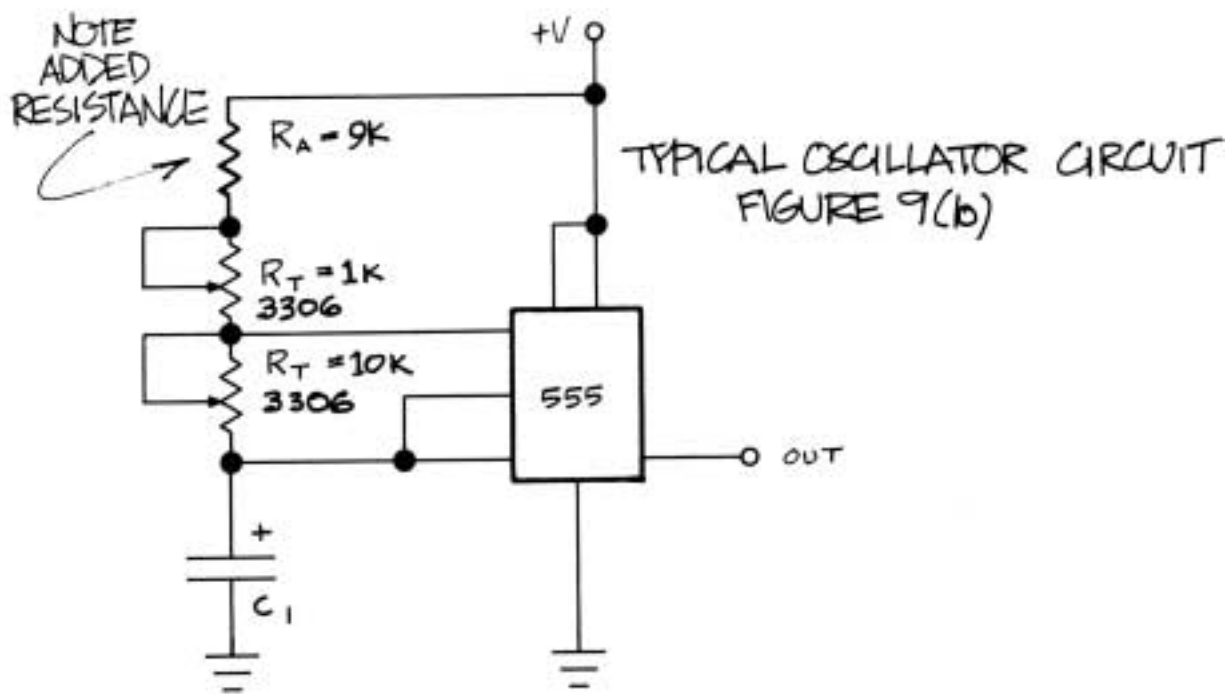

WEIN BRIDGE OSCILLATOR
FIGURE 9(c)

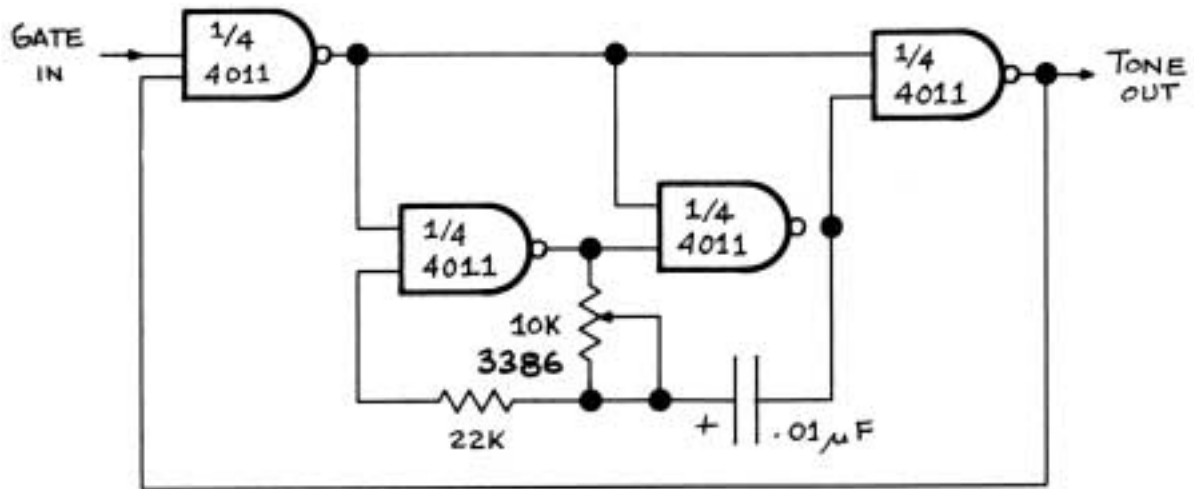

OSCILLATOR GATED TONE BURST OSCILLATOR FIGURE 9(D)

DOING IT THAT WAY CAN SAVE YOU A FIXED RESISTOR OR TWO, BUT YOU'LL PAY THE COST OF REDUCED STABILITY AND DRIFT DUE TO THE POOR MATCH OF CHARACTERISTICS BETWEEN FIXED RESISTORS AND THE TRIMMER.

SO WHAT'S THE RIGHT WAY? LOOK AT FIGURES 9B AND 9C. FOR BEST PERFORMANCE, USE A SERIES FIXED RESISTANCE WITH THE TRIMMER TO PROVIDE ONLY THE RANGE OF ADJUSTMENT REQUIRED BY THE APPLICATION.

LESSON 4

THE HOSTILE ENVIRONMENT CALLED PRODUCTION

IT'S NOT MUCH GOOD GOING TO A LOT OF TROUBLE PICKING OUT THE RIGHT TRIMMER TO MEET THE SPECIFICATIONS OF THE CIRCUIT YOU'RE DESIGNING, IF YOU OVERLOOK THE RIGORS IT HAS TO FACE ON YOUR OWN PRODUCTION LINE.

FROM THE TRIMMER'S POINT OF VIEW, IT'S A JUNGLE OUT THERE.



IN FACT, ONCE YOUR PRODUCT GETS INTO YOUR CUSTOMER'S HANDS, THE HARDEST PART OF THE TRIMMERS LIFE MAY BE PAST. STRESSES INFLECTED BY ASSEMBLY PROCESSES CAN CAUSE INTERFACE SEALS WITHIN THE COMPONENT TO DETERIORATE, EXPOSING INTERNAL MECHANISMS TO THE CORROSIVE INFLUENCES OF MOISTURE AND CONTAMINATES, ELECTRICAL AND MECHANICAL PERFORMANCE MAY BE DEGRADED. THIS IS PARTICULARLY DAMAGING TO COMPLEX COMPONENTS SUCH AS TRIMMING POTENTIOMETERS.

SOLDERING IS A GOOD EXAMPLE.

AT ONE TIME, SOLDERING WAS DONE THE “OLD FASHIONED WAY” BY HAND. IN THE RIGHT HANDS ALL WAS FINE. IN THE WRONG HANDS OR WITH THE WRONG TOOLS, COMPONENTS TRULY GOT “BURNED IN”.

SO WHEN WAVE SOLDERING CAME ALONG WE ACTUALLY BREATHED A SIGH OF RELIEF. IT WAS HOT, BUT CONSISTENT.



TO EVALUATE THE RIGORS THAT TRIMMERS MUST UNDERGO ON YOUR PRODUCTION LINE, IT MAY BE HELPFUL TO COMPARE THE WAVE SOLDERING METHODS AT YOUR COMPANY WITH THE RESULTS OF AN INDUSTRY SURVEY BY BOURNS.

SURVEY RESULTS (REPORTED AS THE CHOICE BY COMPANIES SURVEYED):

TYPE OF FLUX

ACTIVATED ROSIN _____ 87%
ORGANIC ACID _____ 13%

APPLICATION OF FLUX

CONTROLLED FOAM _____ 74%
SPRAY _____ 15%
OTHER (BRUSH, DIP, FLUX PASTE) _____ 11%

BOARD PREHEATING

850C FOR 22 SEC. (APPROX)	_____	41%
1400C FOR 15 SEC. (APPROX)	_____	24%
PREHEATING NOT USED	_____	35%

SOLDERING TIME AND TEMPERATURE

2500C FOR 5 SEC.	_____	30%
2600C FOR 6 SEC.	_____	28%
2300C FOR 3 SEC.	_____	19%
2400C FOR 4 SEC.	_____	18%
2200C FOR 2 SEC.	_____	5%

BOARD WASHING.

THIS PROCESS, DESIGNED TO REMOVE EXCESS FLUX AND CONTAMINANTS FROM THE BOARD, SUBJECTS THE COMPONENTS TO TIDAL WAVE, CAUSING A SUDDEN TEMPERATURE DROP THAT IS EVEN MORE SHATTERING THAN THE SUDDEN RISE DURING SOLDERING. SHOCK! THINK OF A BLACKSMITH PLUNGING A

HORSESHOE INTO A BUCKET OF WATER AND YOU GET AN IDEA OF THE SHOCK BOARDWASHING CAN GIVE THE CIRCUIT BOARD.

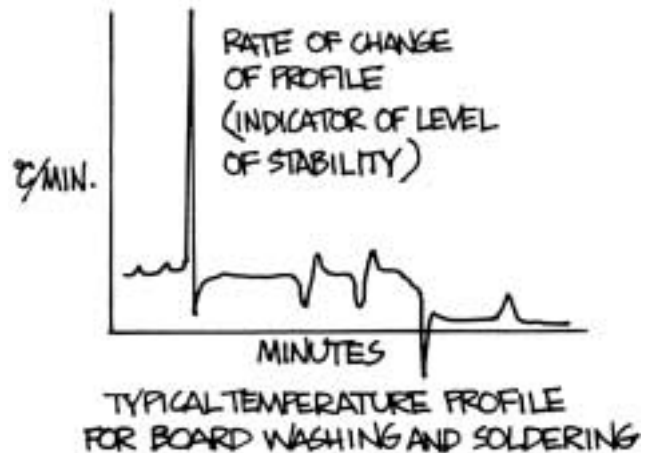

THE WATERBATH COMMONLY USED FOR BOARDWASHING CAN LOWER AIR TEMPERATURE SO QUICKLY THAT A PARTIAL VACUUM IS CREATED THAT CAN SUCK IN CONTAMINATES LIKE A VACUUM CLEANER.

TO HELP YOUR TRIMMERS SURVIVE PRINTED CIRCUIT BOARD PROCESSING:

FAN THEM -USE A COOLING FAN TO DROP THE TEMPERATURE AFTER SOLDERING, BUT BEFORE THE UNITS ENTER THE WASH

SLOW THEM -ADD A SHORT DELAY BEFORE CLEANING, TO PROVIDE A COOLING TIME.

A FINAL CHECKLIST

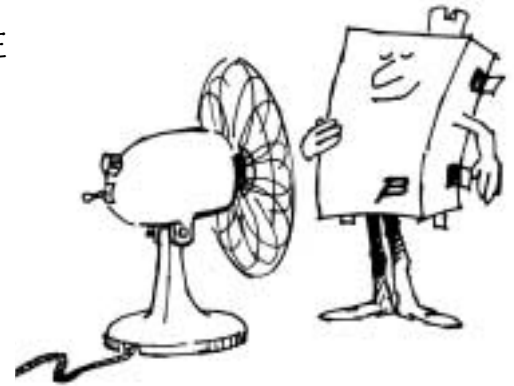

- ☑ TO MINIMIZE TEMPERATURE SHOCK OF SOLDERING, PREHEAT BOARDS AND REDUCE SOLDER TIME.
- ☑ TO AVOID HEATING COMPONENTS ABOVE MAX. TEMPERATURES, USE THE LOWEST POSSIBLE SOLDER TEMPERATURE AND THE MAXIMUM ALLOWABLE CONVEYOR SPEED CONSISTENT WITH GOOD SOLDERING PRACTICES.
- ☑ TO REDUCE SHOCK WHEN TRIMMERS HIT THE WASH, USE A WASH/RINSE TEMPERATURE CLOSE TO THE COMPONENT TEMPERATURE. EXTEND TIME BETWEEN THE SOLDER PROCESS AND THE WASH TO ALLOW COOLING OF THE BOARD AFTER SOLDER AND BEFORE THE WASH.
- ☑ AND TO MINIMIZE THE EFFECT OF MOISTURE, USE AS FEW WASH/RINSE AND RINSE/DRY CYCLES AS POSSIBLE, AND USE HEATED AIR KNIVES.
- ☑ TO REDUCE RISK OF SHOCK WHEN TRIMMERS HIT THE WASH, USE A WASH /RINSE TEMPERATURE CLOSE TO THE COMPONENT TEMPERATURE. EXTEND TIME BETWEEN THE SOLDER PROCESS AND THE WASH TO ALLOW COOLING OF THE BOARD AFTER SOLDER AND BEFORE THE WASH.

OUR SEALS OF APPROVAL

BOURNS TRIMMERS PROVIDE THE BEST POSSIBLE SEALING -
BOURNS RE-DESIGNED ITS TRIMMERS BY MOVING THE SEAL TO A
POSITION THAT MAKES LEAKAGE A GREAT DEAL LESS LIKELY.

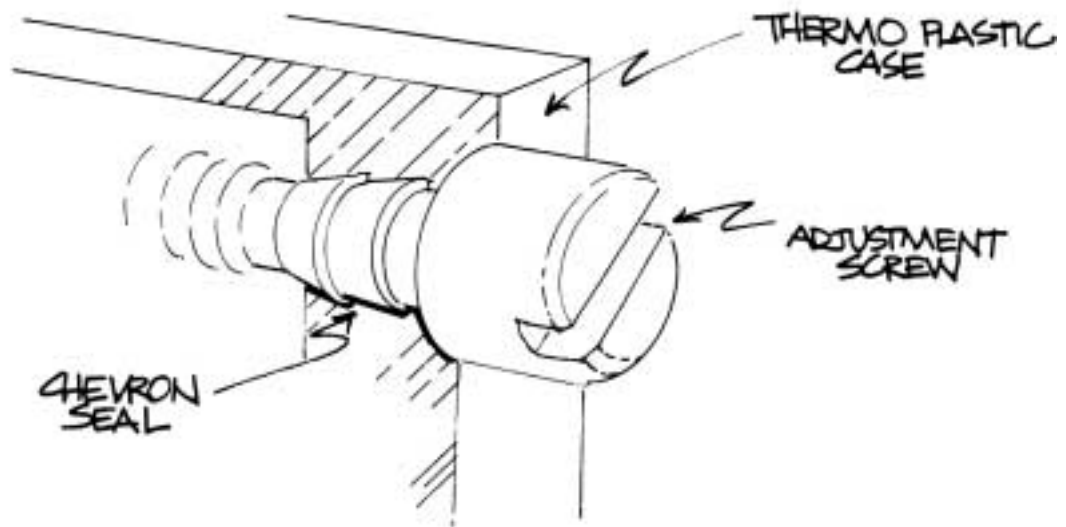

BOURNS TRIMMER SEAL

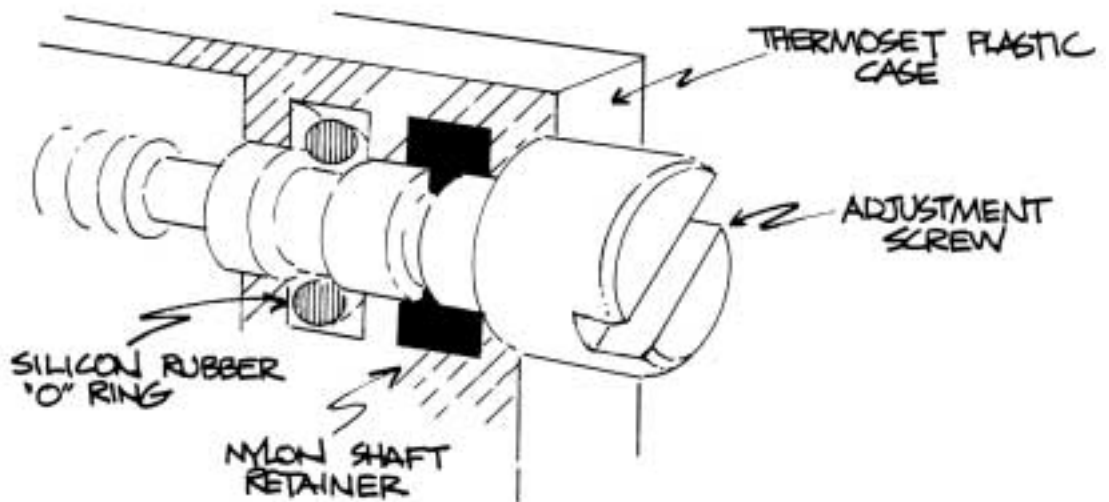

TYPICAL TRIMMER SEAL

THE SEALING OF BOURNS TRIMMERS IS FUNCTIONALLY SUPERIOR TO OTHER UNITS ON THE MARKET.

ALL BOURNS SEALED TRIMMERS MEET THE MOST RIGOROUS QUALITY STANDARDS IN IMMERSION TESTING. BOURNS WAS A PIONEER IN APPLYING THE RIGOROUS TESTING STANDARDS OF THE FLOURINERT* IMMERSION TEST COUPLED WITH VERIFICATION BY A THERMAL SHOCK AND DYE PENETRATION TEST.

YOUR BEST PROTECTION AGAINST SOLDERING WASHING PROBLEMS IS TO BUY TRIMMERS FROM A STATE-OF -THE-ART MANUFACTURING OF PRODUCTS, DESIGNED TO MEET THE RIGORS OF TODAY'S PRODUCTION ENVIRONMENT....

BOURNS!

THE MECHANICAL MENACE

CONSIDER WHICH OF THESE COMMON PRODUCTION-LINE HAZARDS THE TRIMMER WILL HAVE TO ENDURE AND SELECT A PRODUCT THAT'S SUITABLE TO THE CHALLENGE.

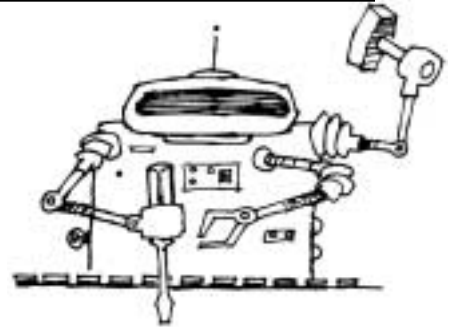

- ☑ AUTO INSERTION-IF THE TRIMMERS WILL BE INSERTED BY MACHINE, SELECT MODELS THAT HAVE TERMINATIONS STRONG ENOUGH TO WITHSTAND THE FORCES.

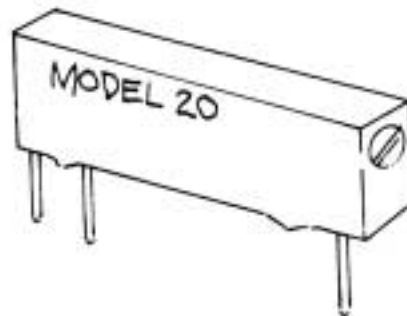
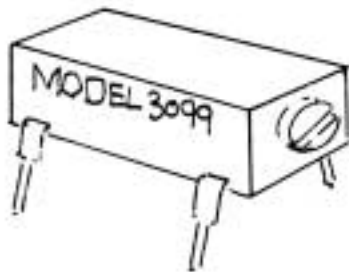

BOURNS DIP AND SIP TRIMMERS ARE BUILT RUGGED TO MEET THE DEMANDS OF AUTOMATIC INSERTION.

- ☑ AUTOMATIC TRIMMER ADJUSTMENT-ROBOTIC EQUIPMENT IS NOW AVAILABLE THAT CAN MEASURE CIRCUIT PARAMETERS AND MAKE NECESSARY TRIMMER ADJUSTMENTS AUTOMATICALLY.

IF YOU HAVE REQUIREMENTS FOR VERY HIGH-VOLUME PRODUCTION, YOU MAY WANT TO SUGGEST THIS EQUIPMENT FOR YOUR COMPANY. BOURNS CAN PROVIDE AN ADJUSTMENT SCREW HEAD THAT IS COMPATIBLE WITH ROBOTIC EQUIPMENT.

✓ ADJUSTMENT SCREW HEAD CEMENTING.— A MULTI-TURN TRIMMER ADJUSTMENT SCREW IS SELF-LOCKING. EVEN WHERE THE UNIT WILL BE SUBJECTED TO VIBRATION OR SHOCK, THERE IS RARELY A NEED TO CEMENT THE ADJUSTMENT SCREW IN POSITION. IN MOST APPLICATIONS THE ONLY REASONS TO DO SO WOULD BE TO PREVENT THE USER FROM MAKING ADJUSTMENTS OR TO TELL IF AN UNAUTHORIZED ADJUSTMENT HAS BEEN MADE.

✓ TRIMMER LOCATION - YOU'VE HEARD OF A POT HANDLE? IF YOU PUT THE POT IN THE WRONG PLACE ON YOUR BOARD, PEOPLE WILL USE IT AS A HANDLE FOR PICKING UP THE BOARD. KEEP THIS HAZARD IN MIND WHEN LAYING OUT YOUR BOARD.

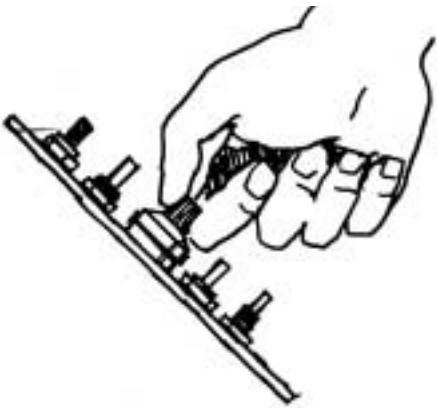

NOTE: IN THE WRONG LOCATION, A POT BECOMES A POT HANDLE.

FINAL INSPECTION MADE EASIER

USING THE RIGHT TOOL- ADJUSTING TRIMMERS AT FINAL INSPECTION CAN BE DONE MORE EASILY, QUICKLY AND RELIABLY WHEN THE PROPER TOOL IS USED. A SPECIAL "TRIMMER TWEAKER" FROM BOURNS IS DESIGNED FOR THIS TASK. ASK FOR ONE!



THE OPERATING ENVIRONMENT OF THE FINAL PRODUCT

IN SELECTING THE RIGHT TRIMMER FOR THE JOB, YOU NEED TO CONSIDER THE ENVIRONMENT IN WHICH THE PRODUCT YOU'RE BUILDING WILL ULTIMATELY BE USED. THERE ARE SOME FACTORS IN THIS EVALUATION THAT ARE OFTEN OVERLOOKED.



☑ WHERE ACCURACY OF TOTAL RESISTANCE OVER A RANGE OF TEMPERATURES IS IMPORTANT, A WIREWOUND UNIT MAY BE THE CHOICE. THE TEMPCO FOR WIRE-WOUND IS GENERALLY $+50\text{PPM}/^{\circ}\text{C}$ WHEN MEASURED BETWEEN THE ENDS OF THE ELEMENT.

☑ HUMIDITY IS A PARTICULAR PROBLEM FOR CARBON TRIMMERS, DUE TO THE HYDROSCOPIC NATURE OF THE MATERIAL. IN SEALED TRIMMERS CERMET AND WIREWOUND UNITS ARE RARELY AFFECTED. IN FACT, ALL MODELS ROUTINELY PASS THE STRINGENT REQUIREMENTS OF MILITARY SPECIFICATIONS.

☑ IF TEMPCO IS AN IMPORTANT CONSIDERATION, CONTACT BOURNS WITH YOUR SPECIFIC RESISTANCE VALUE AND RANGE OF OPERATING TEMPERATURES INVOLVED. CATALOG SPECIFICATIONS TYPICALLY GIVE MAXIMUM VALUES FROM TESTING HIGH, MEDIUM AND LOW RESISTANCE VALUES OVER A WIDE TEMPERATURE RANGE.

☑ LONG-TERM POWER -THE WAY POWER IS APPLIED CAN HAVE A SIGNIFICANT EFFECT ON THE LIFE AND FUNCTIONING OF THE TRIMMER. AMONG THE FACTORS TO CONSIDER: WILL THE TRIMMER BE USED IN AN AC APPLICATION OR DC? IS HIGH FREQUENCY AC REACTANCE A CONSIDERATION? WILL THE POWER BE ON CONTINUOUSLY FOR LONG PERIODS OF TIME? WILL THE POWER BE CYCLED ON AND OFF REPEATEDLY? ARE MULTIPLE UNITS “STACKED “SIDE -BY-SIDE? WHAT IS THE MAXIMUM AMBIENT TEMPERATURE THE TRIMMER WILL BE SUBJECTED TO?

☑ TRANSPORT—EVEN IF YOUR PRODUCT IS NOT A PORTABLE OR MOBILE PIECE OF EQUIPMENT, DON'T OVER-LOOK THE FACT THAT IT WILL BE SUBJECTED TO THE RIGORS OF SHIPPING BEFORE IT REACHES YOUR CUSTOMER. TAKE INTO ACCOUNT THE EXTREMES OF TEMPERATURE SHOCK AND VIBRATION THAT MIGHT BE ENCOUNTERED.



BOURNS TRIMMERS ARE DESIGNED TO WITHSTAND THE HARSH TREATMENT OF SHIPPING: IN MOST CASES, THEY CAN ENDURE 20-30 G'S OF VIBRATION, 50-100 G'S OF SHOCK, AND TEMPERATURES FROM -55° TO +150° C.

LESSON 5

A LOOK BELOW THE SURFACE OF SMT.

AT BOURNS, WE HAVE BEEN SPENDING MORE AND MORE TIME AND RESOURCES WORKING WITH CUSTOMERS ON THE DEVELOPMENT AND APPLICATION OF SURFACE MOUNTED PRODUCTS.



THE HANDWRITING IS ON THE WALL-
SURFACE MOUNTING IS THE FUTURE
AND BOURNS IS AT THE LEADING
EDGE OF THIS EXCITING TECHNOLOGY.

THIS PRIMER IS ANOTHER EXAMPLE OF THE BOURNS TRIMPOT COMMITMENT TO SMT. AND OUR COMMITMENT TO YOU, THE DESIGNERS OF TOMORROW'S CIRCUITS AND APPLICATIONS.

ENJOY YOUR LOOK BELOW THE SURFACE OF SMT. AND WHEN YOU'RE DONE, TAKE A LOOK AT THE CURRENT LINE-UP OF BOURNS SURFACE MOUNTED TRIMMERS IN OUR LATEST CATALOG.

THE POSSIBILITIES OF SMT.

BEFORE WE START THE HEAVY-DUTY WORK, LET'S EASE BACK INTO CLASS WITH A LITTLE "WHAT IF" DAYDREAMING.

WHAT IF YOU COULD BOOST THE PERFORMANCE OF YOUR CIRCUIT BY 10%, 15%, 20%, OR MORE?



WHAT IF YOU COULD SIMULTANEOUSLY REDUCE NOISE AND CROSSTALK AND GET IMPROVED EMI/RFI CHARACTERISTICS AS WELL?

WHAT IF ALL THESE PERFORMANCE INCREASES CAME WITH A CORRESPONDING DECREASE IN BOARD SIZE LEADING TO A SMALLER CHASSIS LEADING TO A MORE COMPACT PRODUCT?

WHAT IF BOARD ASSEMBLY TIME WAS REDUCED, REWORK VIRTUALLY ELIMINATED AND FIELD FAILURES SO RARE THEY BECOME A CURIOSITY?

WHAT IF IT WASN'T A DAYDREAM? WHAT IF ALL YOUR COMPETITORS HAD SUCH TECHNOLOGY AND IF YOU DIDN'T GET IT SOON THE MARKET WAS GOING TO GIVE YOU "WHAT FOR."

THAT'S ABOUT WHERE SMT IS TODAY.

LET'S TAKE A LOOK BELOW THE SURFACE OF SMT TO UNDERSTAND HOW AND WHY IT OFFERS SUCH BENEFITS.

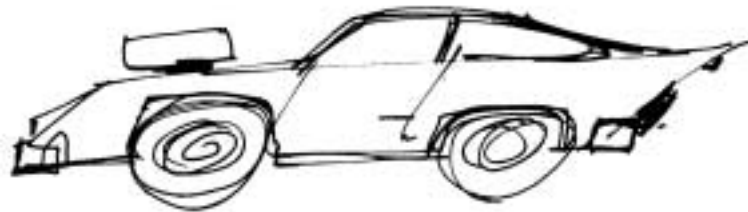

TURBO-CHARGED PERFORMANCE. PERFORMANCE INCREASES RESULT FROM GREATER COMPONENT DENSITY (THE DISTANCE BETWEEN COMPONENTS) AND REDUCTION OR ELIMINATION OF LEAD LENGTH BETWEEN THE COMPONENT AND THE BOARD.

THERE IS SIGNIFICANTLY LESS TRACE RESISTANCE, LESS TRACE INDUCTANCE AND A REDUCTION IN LINE CAPACITANCE WITH SMT.,

THESE SHORTER INTERCONNECTIONS RESULT IN IMPROVED EMI/RFI CHARACTERISTICS TOO. FOR YOU BUZZ WORD LOVERS OUT THERE, IT'S ENOUGH TO SAY THAT THE PACKAGE PARASITICS ARE REDUCED AND THERE'S AN "INDUCTIVE REDUCTION FOR SPEED PRODUCTION."

SIZEABLE SIZE REDUCTIONS. BOARD SIZE CAN BE REDUCED BY AS MUCH AS 60 PERCENT USING SMT COMPONENTS AND PROCESSES. ONE REASON IS THAT WITH SMT, THERE ARE NO THROUGH-BOARD HOLES SO BOARD STUFFING IS NO LONGER A ONE-SIDED STORY. BUT TWO SIDES ADD-UP TO MORE THAN TWICE AS MUCH. THAT'S BECAUSE SMT COMPONENTS ARE SIGNIFICANTLY SMALLER IN SIZE PLUS THEY CAN BE PACKED MORE DENSELY TOGETHER.... ON BOTH SIDES OF THE BOARD.

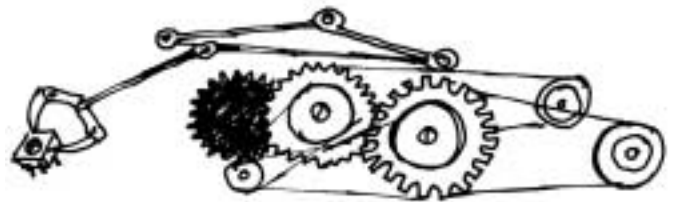

AUTOMATIC SAVINGS.

THE RELATIVE EASE OF AUTOMATING “ONsertion” VS. INSERTION OF LEADED COMPONENTS CAN LEAD TO SIGNIFICANT SAVINGS. THE PICK-AND-PLACE MACHINES COMMONLY USED FOR SMD'S OPERATE EIGHT..TEN..EVEN TWELVE TIMES FASTER THAN HAND OR SEMI-AUTOMATED PROCESSES.

AND, OF COURSE, WHENEVER THE HUMAN ELEMENT IS ELIMINATED, SO TOO, IS HUMAN ERROR— THERE'S LESS REWORK AND REWORK COSTS.

NO PAIN, NO GAIN.



IF IT ALL SOUNDS TOO EASY, YOU HAVE THE EAR OF A SEASONED DESIGNER. THE PATH TO USING ANY NEW TECHNOLOGY- INCLUDING SMT- IS FILLED WITH OBSTACLES. NOT THE LEAST OF WHICH IS OVER CONFIDENCE. IN THE INTEREST OF BALANCED REPORTING, WE FEEL OBLIGATED TO INCLUDE THE PESSIMIST'S VIEW OF SMT.

NEW EQUIPMENT WILL BE NEEDED INCLUDING PICK-AND PLACE MACHINES, SPECIAL SOLDERING MACHINES, AND NEW TEST EQUIPMENT.

CIRCUIT BOARD LAYOUT, COMPONENT AND PAD SPACING IS TIGHTER AND FEW CAD/CAM'S ARE SET UP FOR SMT.

COMPONENT COSTS CURRENTLY RANGE FROM SLIGHTLY HIGHER TO SIGNIFICANTLY HIGHER THAN LEADED EQUIVALENTS.

AVAILABILITY CAN BE A PROBLEM. NOT ALL TYPES OF COMPONENTS ARE OFFERED IN SURFACE MOUNT PACKAGES, THOUGH THIS IS CHANGING RAPIDLY.

SOLDERING PRESENTS SPECIAL CHALLENGES FOR SURFACE MOUNTED PARTS. MORE ON THIS LATER.

ON BALANCE, WE THINK THE POSITIVES EASILY OUTWEIGH THE NEGATIVES.



PROCESSES: THE SCHOOL OF HARD KNOCKS.

THERE'S ONLY ONE PLACE TO START ON THE LEARNING CURVE OF A NEW TECHNOLOGY AND -UNFORTUNATELY- THAT'S THE BOTTOM. BUT WITH THE HELP OF THIS PRIMER AT LEAST YOU WON'T BE STARTING IN THE BASEMENT.



ASSEMBLY OPTIONS

THERE ARE A VARIETY OF ASSEMBLY TECHNIQUES OR OPTIONS. DEPENDING ON WHICH ONE YOU CHOOSE, YOU INFLUENCE YOUR CHOICES OF PICK-AND-PLACE EQUIPMENT AND SOLDERING METHODS.

100% SMD. SURFACE MOUNTED DEVICES ARE SOLDERED TO ONE OR BOTH SIDES OF THE PC BOARD. REFLOW SOLDERING IS MOST COMMONLY USED.

MIXED TECHNOLOGY. THERE ARE SEVERAL OPTIONS IN MIXING THE TECHNOLOGY.

- THROUGH-HOLE AND SMD'S ARE MOUNTED ON THE TOP SIDE OF THE BOARD.
- THROUGH-HOLE AND SMD'S ARE MOUNTED ON THE TOP SIDE AND SMD'S ARE PLACED ON THE BOTTOM SIDE.

CURRENTLY THE MOST POPULAR MIXED OPTION IS TO PLACE THROUGH -HOLE PARTS ON ONE SIDE AND SMD'S ON THE OTHER. OR TO PUT THE SMD'S ON DAUGHTER BOARD.

HOW TO PUT THE RIGHT INSERTION EQUIPMENT INTO YOUR MANUFACTURING PLAN.

SELECTING THE RIGHT EQUIPMENT CAN BE COMPLEX AND REQUIRES THE ANALYSIS OF MANY FACTORS. JUST A FEW GENERIC CONSIDERATIONS INCLUDE:

- HOW MANY BOARDS NEED PROCESSING?
- IN WHAT LENGTH OF TIME?
- WHAT SIZE IS YOUR BOARD?
- HOW MANY COMPONENTS MUST BE PLACED?
- HOW MANY DIFFERENT COMPONENTS WILL BE USED?
- COMPONENT PACKAGING/MACHINE FEEDER TYPE?

THERE ARE FOUR BASIC PLACEMENT METHODS TO CHOOSE FROM-- EACH WITH PARTICULAR STRENGTHS.

IN-LINE PLACEMENT

THE IN-LINE METHOD USES A SERIES OF FIXED-POSITION STATIONS. EACH STATION PLACES A COMPONENT ON THE BOARD WHICH IS THEN MOVED TO THE NEXT STATION FOR PLACEMENT OF ANOTHER COMPONENT. IT IS LIKE A RELAY RACE WITH EACH STATION PERFORMING IN TURN.

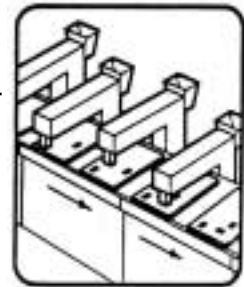



THE IN-LINE METHOD IS BEST SUITED WHEN THE BOARD IS POPULATED WITH A VARIETY OF DIFFERENT SHAPE AND SIZE SMT COMPONENTS. THE GREATER THE NUMBER OF COMPONENTS, THE MORE PLACEMENT STATIONS REQUIRED- THE OUTPUT RATE IS FIXED.

SEQUENTIAL PLACEMENT

THIS METHOD USES A SOFTWARE CONTROLLED X-Y MOVING TABLE TO POSITION THE BOARD UNDER THE PLACEMENT DEVICE. EACH COMPONENT IS PLACED ON THE BOARD IN RAPID SUCCESSION. SEQUENTIAL PICK-AND-PLACE EQUIPMENT HAS PROVEN TO BE A VERY POPULAR METHOD. IT IS THE LEAST EXPENSIVE OF ALL CURRENT METHODS YET IT OFFERS THE MOST FLEXIBILITY IN SETTING UP FOR RELATIVELY SMALL PRODUCTION RUNS. CYCLE TIMES ARE MEASURED PER COMPONENT PLACEMENT RATHER THAN BOARD OUTPUT- THE MORE COMPLICATED AND POPULATED THE BOARD, THE LOWER THE BOARD OUTPUT.

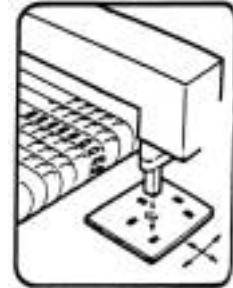

SIMULTANEOUS PLACEMENT

THIS METHOD IS SIMILAR TO THE IN-LINE METHOD WITH ONE BIG EXCEPTION. INSTEAD OF PICKING AND PLACING ONE COMPONENT, IT PLACES AN ENTIRE ARRAY OF ONE TYPE OF COMPONENT ONTO THE BOARD AT THE SAME TIME. EACH BOARD SEES ONLY ONE OPERATION FOR EACH COMPONENT TYPE. THIS METHOD IS BEST SUITED FOR ASSEMBLIES CONTAINING A LARGE NUMBER OF THE SAME TYPE COMPONENT ON A GIVEN BOARD.

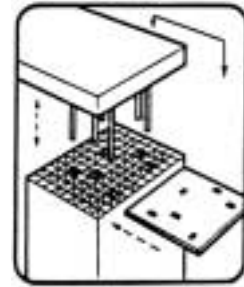

SEQUENTIAL/SIMULTANEOUS PLACEMENT

SEQUENTIAL/ SIMULTANEOUS EQUIPMENT IS THE MASERATI OF PLACEMENT EQUIPMENT. IT COSTS A LOT BUT OH DOES IT PERFORM. THE BOARD IS HELD ON A SOFTWARE CONTROLLED X-Y MOVING TABLE AND THE PLACEMENT IS MADE WITH MULTIPLE HEADS INSTEAD OF ONE.

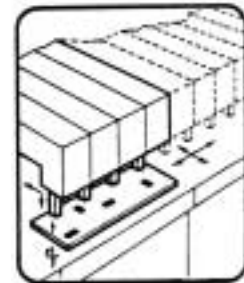

THE THROUGHPUT OF SUCH A MACHINE APPROACHES 300,000 COMPONENTS PER HOUR-DEPENDING, OF COURSE, ON THE TYPE AND MIX-AND IS MOST SUITABLE FOR VERY HIGH VOLUME APPLICATIONS.

PACKAGING. A MATCH FOR YOUR PLACEMENT METHOD.

AFTER DETERMINING THE TYPE OF PICK-AND-PLACE EQUIPMENT FOR YOUR APPLICATION, YOU FACE THE PACKAGING ISSUE. YOU CAN ADAPT THE FEEDER MECHANISMS OF YOUR PLACEMENT EQUIPMENT TO HANDLE ALMOST ANY SMT COMPONENT PACKAGING.

BOURNS TRIMPOT SURFACE MOUNTED TRIMMERS COME IN ONE OF THREE PACKAGES DEPENDING ON COMPONENT SIZE.

- CARRIER TAPE (A.K.A. EMBOSSED TAPE)
- CARTRIDGE (A.K.A. PLASTIC TUBES)
- TRAYS (A.K.A. WAFFLES)

CARRIER TAPE HOLDS PARTS AND DELIVERS THEM ONE-BY-ONE TO THE PICK-UP HEAD. EMBOSSED TAPE IS THE NATURAL MATCH FOR ALL TYPES OF PICK-AND-PLACE EQUIPMENT.



CARTRIDGE PACKAGING OFFERS A WAY OF HANDLING LARGER SURFACE MOUNTED TRIMMING POTENTIOMETERS AND OTHER SURFACE MOUNTED PARTS. FREQUENT RELOADING IS NECESSARY WHEN USED WITH HIGH PERFORMANCE MACHINES.

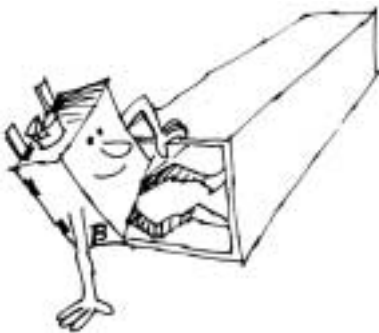

WAFFLE PACK CARRIERS ARE TRAYS IN WHICH DEVICES ARE PLACED PROPERLY ORIENTED AND READY FOR PICK-UP. IT IS EXCELLENT FOR ODD-SHAPED UNITS THAT DO NOT LEND THEMSELVES TO TAPE OR CARTRIDGE PACKAGING. THE DISADVANTAGE IS THAT THE INSERTION EQUIPMENT MUST PICK AT A DIFFERENT LOCATION EACH TIME.

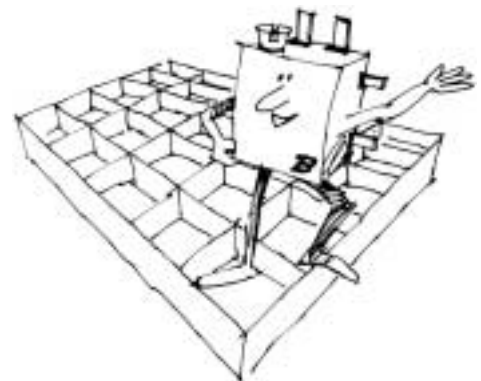

SOLDERING. WHERE THE SMT ISSUE REALLY HEATS UP.

AT BOURNS, THE WATCHWORDS ARE “PROCESSES DRIVE PRODUCT DESIGNS.” WHETHER THEY’RE PLACEMENT PROCESSES, CLEANING PROCESSES OR TESTING PROCESSES.

WHILE THE MAJORITY OF THE BOURNS TRIMMING POTENTIOMETER LINE IS OPTIMIZED FOR “CONVENTIONAL” PROCESSES, A GROWING NUMBER OF OUR PRODUCTS HAVE BEEN DEVELOPED TO RESPOND TO THE NEW DEMANDS OF SMT. AND TOMORROW’S SMT PRODUCTS WILL CARRY THESE OPTIMIZATION STEPS EVEN FURTHER.

THE SOLDERING TECHNIQUES USED FOR SMT DEVICES PRESENT UNIQUE DESIGN AND SPECIFICATION CHALLENGES. GENERALLY THE CONCERN CENTERS ON THE MAXIMUM TEMPERATURE AND EXPOSURE TIME. AND UNFORTUNATELY, THE RELATIONSHIP BETWEEN THESE TWO VARIABLE IS NOT LINEAR. A FEW EXAMPLES WILL DEMONSTRATE.

DUAL-WAVE SOLDERING IS THE PROCESS OF CHOICE FOR MANY BOARDS THAT USE BOTH LEADED AND SURFACE MOUNT PARTS. IN THIS PROCESS, SURFACE MOUNTED COMPONENTS ARE ADHESIVELY ATTACHED TO THE UNDERSIDE OF THE BOARD WHILE LEADED DEVICES ARE INSERTED THROUGH THE BOARD. THE ASSEMBLY IS THEN PASSED OVER TWO WAVES OF FLOWING SOLDER. THE SOLDER COOLS AND BONDS BOTH TYPES OF COMPONENTS TO THE BOARD.

BUT THE TEMPERATURES NORMALLY ENCOUNTERED IN THIS METHOD CAN PRESENT SIGNIFICANT PROBLEMS FOR SOME SURFACE MOUNTED COMPONENTS. DUAL-WAVE SOLDERING COULD EXPOSE THESE PARTS TO TEMPERATURES OF 260-265°C FOR 10-12 SECONDS. THIS TIME/TEMPERATURE EXPOSURE MAY COMPROMISE THE SEAL INTEGRITY OF SOME COMPONENTS.

NOTE:

BOURNS MODEL 3314, A 4MM SEALED TRIMMING POTENTIOMETER, SETS A NEW STANDARD FOR HEAT RESISTANCE- IT CAN WITHSTAND TOTAL IMMERSION AT 265°C FOR UP TO 30 SECONDS WITH 100% RELIABILITY.



INCLINE WAVE SOLDERING GENERALLY CAUSES LOWER COMPONENT TEMPERATURES BECAUSE OF SHORTER EXPOSURE WHILE THE BOARD PASSES AN INCLINED PORTION OF THE SOLDER WAVE. ALSO LESS OF THE BOARD IS EXPOSED TO THE WAVE.

THERE IS POTENTIALLY AN ADDITIONAL PROBLEM WITH WAVE SOLDERING THAT IS REFERRED TO AS "SHADOWING." AS LEAD SPACING DECREASES, PARTICULARLY WITH PACKAGES THAT HAVE LEADS ON ALL FOUR SIDES, ONE DEVICE CASTS A "SHADOW" OVER OTHER COMPONENTS, HINDERING COMPLETE SOLDER COVERAGE.



SOLDER PASTE REFLOW IS AN EXCELLENT METHOD FOR BOARDS DENSELY PACKED WITH SURFACE MOUNTED DEVICES.

WITH THIS METHOD, SOLDER IS SCREENED ONTO THE BOARD, THE DEVICES ARE POSITIONED, THE BOARD IS THEN HEATED SO THAT THE SOLDER MELTS AND BONDS. HEATING CAN BE ACCOMPLISHED BY SEVERAL METHODS, THE MOST COMMON BEING BY CONVECTION, INFRARED, OR IMMERSION INTO HEATED FLUORINERT* VAPOR. IN THE CONVECTION METHOD, THE BOARD MUST LIE FLAT ON A HEATED CONVEYOR WHICH TRANSPORTS THE ASSEMBLY THROUGH CONTROLLED HEATING ZONES.

INFRARED REFLOW USES INFRARED RADIATION AS THE HEAT SOURCE. BUT BE CAREFUL, EACH COMPONENT ABSORBS INFRARED RADIATION AT A DIFFERENT RATE DEPENDING ON ITS MATERIAL STRUCTURE AND COLOR. POTENTIALLY, TWO COMPONENTS SITTING SIDE BY SIDE MIGHT BE EXPOSED TO THE SAME LEVEL OF RADIATION WITH ONE BEING STRESSED WHILE THE OTHER ISN'T.



THE VAPOR PHASE REFLOW METHOD USES A FLUID THAT VAPORIZES AT A HIGHER TEMPERATURE THAN THE MELTING POINT OF THE SOLDER PASTE. THE BOARD ASSEMBLY IS IMMERSSED IN THE VAPOR TO MAKE THE PASTE FLOW. TYPICALLY, VAPOR PHASE REFLOW EXPOSES THE TRIMMING POTENTIOMETER TO TEMPS. OF 215°C FOR UP TO THREE MINUTES. THIS LEVEL OF EXPOSURE WILL NOT AFFECT THE MECHANICAL INTEGRITY OF THE BOURNS SEALED TRIMMERS.



HAVEN'T WE TALKED TOO MUCH ABOUT SOLDERING?

NOT BY A LONG SHOT. AND NOT JUST BECAUSE THE ELECTRICAL CONNECTION IS SO IMPORTANT. WITH SMT, THE MECHANICAL STRENGTH OF THE JOINT ASSUMES ADDED IMPORTANCE SINCE THERE ARE NO CLINCHED LEADS TO HOLD THE PART DOWN.

THERMAL MISMATCHING

THERE IS ALWAYS THE POSSIBILITY OF A THERMAL MISMATCH BETWEEN THE SMT COMPONENTS AND THE BOARD. THIS CAN BE A SERIOUS RELIABILITY PROBLEM FOR THE SOLDER CONNECTIONS. IF THE EXPANSION RATE OF THE BOARD IS SUBSTANTIALLY DIFFERENT FROM THE COMPONENTS, THE SOLDER JOINTS CAN FRACTURE UNDER LOAD. TO MINIMIZE THE RISK OF THERMAL EXPANSION FAILURES, WE USE THE 0.30 INCH RULE OF THUMB RELATED TO LEADLESS CONFIGURATIONS, IN OTHER WORDS, IF THE SIZE OF THE TRIMMING POTENTIOMETER IS GREATER THAN 0.30 INCHES, WE WILL NOT MANUFACTURE IT AS A LEADLESS SMT DEVICE. COMPLIANT LEADS ABSORB EXPANSION DIFFERENCES.

IN GENERAL, A SYSTEM SHOULD BE ADJUSTED TO PROVIDE SUFFICIENT HEAT TO ENSURE A GOOD SOLDER CONNECTION. PERIOD!

WHERE WE STAND ON SMT



WORKING WITH DESIGNERS AND WATCHING THE TRENDS IN THE USE OF SMT, BOURNS HAS TAKEN THE LEAD IN DEVELOPING AND REFINING THE TECHNOLOGY.

LEADED VS. LEADLESS, BOURNS SUPPORTS THE USE OF LEADED COMPONENTS, ESPECIALLY “GULL WING” CONFIGURATIONS. HERE’S WHY:

- LEADED COMPONENTS PROVIDE BUILT-IN STAND-OFFS PERMITTING THOROUGH BOARD CLEANING.
- LEADED SMT COMPONENTS ALSO ALLOW VISUAL INSPECTION OF THE SOLDER JOINTS.
- “GULL WING” LEADS PROVIDE TEST POINTS THAT ARE UNAVAILABLE WITH OTHER CONFIGURATIONS.

STANDARDS. BOURNS BELIEVES THE LACK OF STANDARDS HAS SLOWED THE USE OF SMD’S.

IN SUPPORT OF STANDARDIZATION, BOURNS INITIATED A PROGRAM WITH SEVERAL INDUSTRY ORGANIZATIONS TO SET STANDARDS ON SURFACE MOUNTED TRIMMING POTENTIOMETER LEAD SPACING, OVERALL COMPONENT HEIGHT, MAXIMUM TEMPERATURE/ TIME EXPOSURE LIMITS AND PACKAGING.

BOURNS IS COMMITTED TO SMT. FROM 1983 TO 1988 BOURNS DEVELOPED AND INTRODUCED SIX SMT TRIMMER MODELS-BOTH SINGLE AND MULTI-TURN, SEALED AND OPEN FRAME, LEADED AND UNLEADED. THE FOLLOWING BOURNS TRIMPOT SELECTION MATRIX CONTAINS ONLY THE PARTS AVAILABLE AT TIME OF PUBLICATION. NEW MODELS AND IMPROVEMENTS ARE CONSTANTLY BEING DEVELOPED AND INTRODUCED. CONTACT YOUR BOURNS REPRESENTATIVE FOR THE MOST CURRENT LIST OF AVAILABLE COMPONENTS.

THE SMD PRODUCTS
 MODEL 3314, 4 MM, SQUARE, SINGLE-TURN

LEADING OFF THE LIST OF LEADED AND LEADLESS SMD'S IS THE MODEL 3314. THIS 4MM SEALED DEVICE IS THE ONLY SMD TRIMMER THAT WILL BEAT THE HEAT, EVEN DUAL WAVE! FACT IS THE 3314 HAS THE INDUSTRY'S HIGHEST THERMAL SAFETY MARGIN.

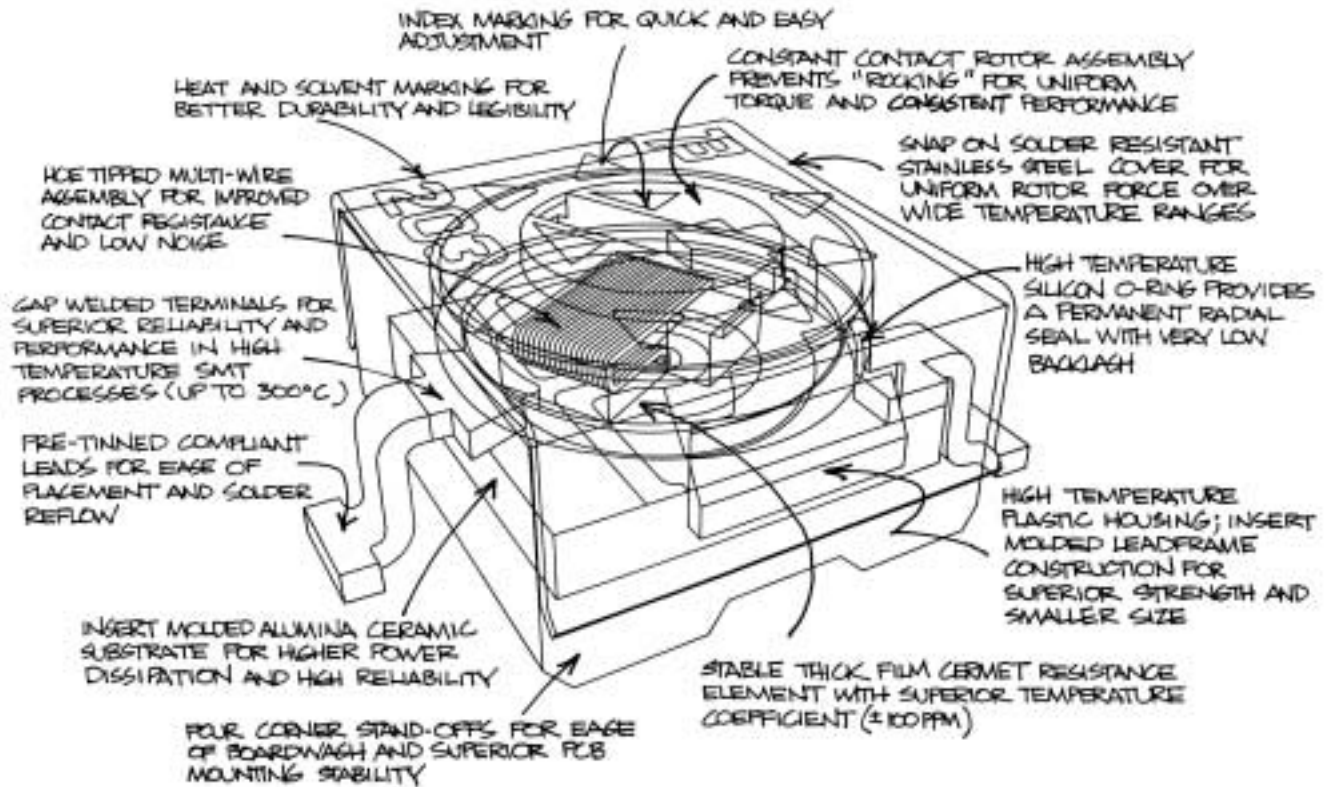

STANDARD RESISTANCE RANGE

.....10Ω TO 2 MEGOHMS

RESISTANCE TOLERANCE.....± 20% STD.

CONTACT RESISTANCE VARIATION

.....1% OR 3 OHMS
 (WHICHEVER IS GREATER)

DIELECTRIC STRENGTH

SEA LEVEL.....500 VAC (1 MINUTE)

ADJUSTMENT ANGLE.....210° NOMINAL

SOLDER IMMERSION EXPOSURE

RECOMMENDED MAXIMUM SOLDERING
 TIME/TEMP LIMITS. 215° C/3 MINUTES

.....265° C/30 SECONDS

.....300° C/10 SECONDS

RESISTANCE TO SOLDERING IRON HEAT

.....350° C/10 SECONDS

TR 1% MAXIMUM

POWER RATING (300 VOLTS MAXIMUM)

70° C.....0.25 WATT

125° C.....0 WATT

TEMPERATURE RANGE

.....-55° C TO +125° C

TEMPERATURE COEFFICIENT

.....+ 100PPM/°C

HUMIDITY.....80-90% RH,

10 CYCLES, 240 HOURS

TR 2%, IR 10 MEGOHMS

SEAL TEST.....85° C FLOURINERT*

VIBRATION.....20G TR 1% VR 1%

SHOCK.....100G TR 1%, VR 1%

**"FLOURINERT" IS A REGISTERED TRADEMARK OF 3M CO.

MODEL 3304
4 MM, SQUARE, SINGLE-TURN



- NEW SMD CHIP DESIGN
- CROSS SLOT ROTOR FOR ALL POPULAR "PICK-AND-PLACE" EQUIPMENT
- ENHANCED PERFORMANCE CHARACTERISTICS
- VERTICAL ADJUST STYLE
- EMBOSSED TAPE PACKAGED

MODEL 3325
.250"(.6MM), ROUND, SINGLE-TURN



- VERTICAL AND HORIZONTAL ADJUST STYLES
- SIDE-ADJUST ADAPTER (.100 "LEAD SPACING)
-

STANDARD RESISTANCE RANGE	500 OHMS TO 1 MEGOHM	10 OHMS TO 1 MEGOHM
RESISTANCE TOLERANCE	+ 25% STANDARD	+ 10% STANDARD
ABSOLUTE MINIMUM RESISTANCE	5% MAXIMUM	2 OHMS MAXIMUM
CONTACT RESISTANCE VARIATION	5% MAXIMUM	3.0% OR 3 OHMS (WHICHEVER IS GREATER)
ADJUSTABILITY		VOLTAGE...+ 0.15%
RESOLUTION	INFINITE	INFINITE
INSULATION RESISTANCE		500 VDC, 1000 MEGOHMS MIN.
DIALECTIC STRENGTH		SEA LEVEL - 600 VAC
ADJUSTMENT ANGLE	230° NOMINAL	80,000 FEET...250 VAC
MAXIMUM EXPOSURE		240° NOMINAL
POWER RATING	70° C.....0.2 WATT 125° C..... 0 WATT (50 VOLTS MAXIMUM)	+ 215° C/3 MINUTES 85- C.... 0.5 WATT 150°C...0 WATT (300 VOLTS MAXIMUM)
TEMPERATURE RANGE	-55° C TO + 125° C	-55°C TO +150°C
TEMPERATURE COEFFICIENT	+ 2500 PPM/ °C NOMINAL	1100 PPM/°C
HUMIDITY		MIL-STD- METHOD 103 (96 HRS.) IR 10 MEGOHMS MIN.
LOAD LIFE		1000 HOURS 0.5 WATT AT 85° C
SEAL TEST		85° C FLUORINERT *
VIBRATION		30 G
SHOCK		100 G
MECHANICAL LIFE	20 CYCLES	200 CYCLES
MECHANICAL ANGLE		2600 NOMINAL
TORQUE	3.0 OZ-IN MAXIMUM	3.0 OZ-IN MAXIMUM
STOP STRENGTH		5.0 OZ-IN MINIMUM
TERMINALS		SOLDERABLE PINS
WEIGHT		0.070Z

*"FLUORINERT" IS A REGISTERED TRADEMARK OF 3M CO.

MODEL 3335

.200"(5MM), SQUARE, SINGLE-

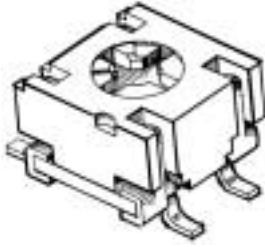

TURN

- VERTICAL ADJUST STYLE
- AUTOMATIC MACHINE ADJUST ROTOR DESIGN
- FLOURINERT* TESTED
- EMBOSSED TAPE PACKAGED
- 3 AND 4 PIN DESIGNS

MODEL 3269

.250"(6MM) SQUARE, MULTI-TURN

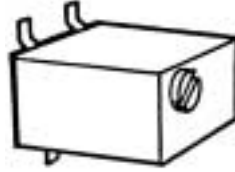

- VERTICAL AND HORIZONTAL ADJUST STYLES
- SEALED TO WITHSTAND IMMERSION CLEANING
- FLOURINERT* TESTED
- PLASTIC TUBE PACKAGED

MODEL 3272

.350"(9MM), ROUND, MULTI-TURN
• HORIZONTAL ADJUST STYLE

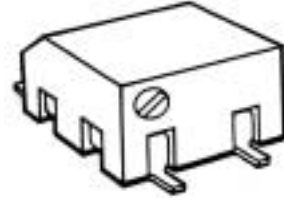

- GULL WING PAD CONFIGURATION
- UNIQUE CONSTRUCTION
- EXCEPTIONAL SETTING STABILITY AFTER HIGH TEMP. EXPOSURE
- SEALED TO WITHSTAND IMMERSION CLEANING
- FLUORINERT* TESTED
- PLASTIC TRAY PACKAGED

10 OHMS TO 500,000 OHMS	10 OHMS TO 1 MEGOHM	100 OHMS TO 1 MEGOHM
± 20% STANDARD	+ 10% STANDARD	+ 10% STANDARD
2 OHMS MAXIMUM	1 OHM MAXIMUM	1 OHM MAXIMUM
3.0% OR OHMS (WHICHEVER IS GREATER)	3.0 % OR 3 OHMS (WHICHEVER IS GREATER)	1.0% OR 3 OHM (WHICHEVER IS GREATER)
VOLTAGE...±0.05%	VOLTAGE...+ 0.02%	VOLTAGE...+ 0.02%
RESISTANCE.....± 0.15%	RESISTANCE...+ 0.05%	RESISTANCE...+ 0.05%
INFINITE	INFINITE	INFINITE
500 VDC, 1000 MEGOHMS MIN.	500 VDC, 1000 MEGOHMS MIN.	500 VDC, 100 MEGOHMS MIN.
SEA LEVEL.... 600 BAC	SEA LEVEL... 600 VAC	SEA LEVEL..... 600 VAC
80,000 FEET... 250 VAC	80,000 FEET... 250 BAC	80,000 FEET... 250 VAC
240° NOMINAL	EFFECTIVE TRAVEL..12 TURNS NOM.	EFFECTIVE TRAVEL.. 12 TURNS NOM.
± 215° C/3 MINUTES	+215° C /3 MINUTES	+ 215 C/3 MINUTES
85° C....0.2 WATT	85° C... 0.25 WATT	85° C....0.25 WATT
150° C...0 WATT	150° C... 0 WATT	150° C0 WATT
(200 VOLTS MAX.)	(300 VOLTS MAX.)	(300 VOLTS MAX.)
-55° C TO + 150° C	-65° C TO + 150° C	-65° C TO + 150° C
+ 100 PPM/O C MAX.	± 100 PPM/° C MAX.	+ 100 PPM/° C MAX.
MIL-STD-202 METHOD 103 (96 HRS)	MIL-STD-202 METHOD 106	MIL-STD-202 METHOD 106
IR 10 MEGOHMS MIN.	IR 100 MEGOHMS MIN.	IR 100 MEGOHMS MIN.
1000 HOURS 0.2 WATT AT 85° C	1000 HOURS 0.25 WATT AT 85° C	1000 HOURS 0.25 WATT AT 85° C
85° C FLOURINERT*	85° C FLUORINERT*	85° C FLURINERT*
30 G	30 G	30 G
100 G	100 G	100 G
200 CYCLES	200 CYCLES	200 CYCLES
260° NOMINAL	16 TURNS NOMINAL	16 TURNS NOMINAL
3.0 OZ-IN. MAXIMUM	3.0 OZ-IN. MAXIMUM	3 OZ-IN. MAXIMUM
4.0 OZ-IN. MINIMUM	WIPER IDLES	WIPER IDLES
SOLDERABLE PINS	SOLDERABLE PINS	SOLDERABLE PINS
0.02 OZ	0.015 OZ	0.02 OZ

POST GRADUATE STUDY

THERE'S MUCH MORE TO LEARN AND MUCH MORE TO TELL THAN WHAT WE COULD INCLUDE HERE. AFTER ALL, THIS IS ONLY A PRIMER. IF YOUR GOAL IS TO GET A MASTER'S IN SMT, WE CAN RECOMMEND A COURSE OF STUDY. IN PREPARING THE PRIMER, OUR RESEARCH UNCOVERED NUMEROUS ARTICLES AND OTHER SOURCES OF INFORMATION.



**AND WHEN YOU'RE READY FOR SOME HANDS-ON EXPERIENCE-
REMEMBER BOURNS HAS THE PRODUCTS YOU NEED.**

Worldwide Sales Offices

Country/Region	Phone	Fax
Americas:	+1-951-781-5500	+1-951-781-5006
Brazil:	+55 11 5505 0601	+55 11 5505 4370
China:	+86 21 64821250	+86 21 64821249
Europe, Middle East, Africa:	+36 88 520 390	+36 88 520 211
Japan:	+81 49 269 3204	+81 49 269 3297
Korea:	+82 70 4036 7730	+886 2 25624116
Singapore:	+65 6348 7227	+65 6348 1272
Taiwan:	+886 2 25624117	+886 2 25624116
Other Asia-Pacific Countries:	+886 2 25624117	+886 2 25624116

Technical Assistance

Region	Phone	Fax
Asia-Pacific:	+886 2 25624117	+886 2 25624116
Europe, Middle East, Africa:	+36 88 520 390	+36 88 520 211
Americas:	+1-951-781-5500	+1-951-781-5700

www.bourns.com

Bourns® products are available through an extensive network of manufacturer's representatives, agents and distributors.

To obtain technical applications assistance, a quotation, or to place an order, contact a Bourns representative in your area.

Specifications subject to change without notice. Actual performance in specific customer applications may differ due to the influence of other variables. Customers should verify actual device performance in their specific applications.

BOURNS®

"Bourns" and "Trimpot" are registered trademarks of Bourns, Inc. in the U.S. and other countries.

COPYRIGHT© 2015, BOURNS, INC. • 07/15 • XX/T1513